

## Clear Floor Two-Post Lifts

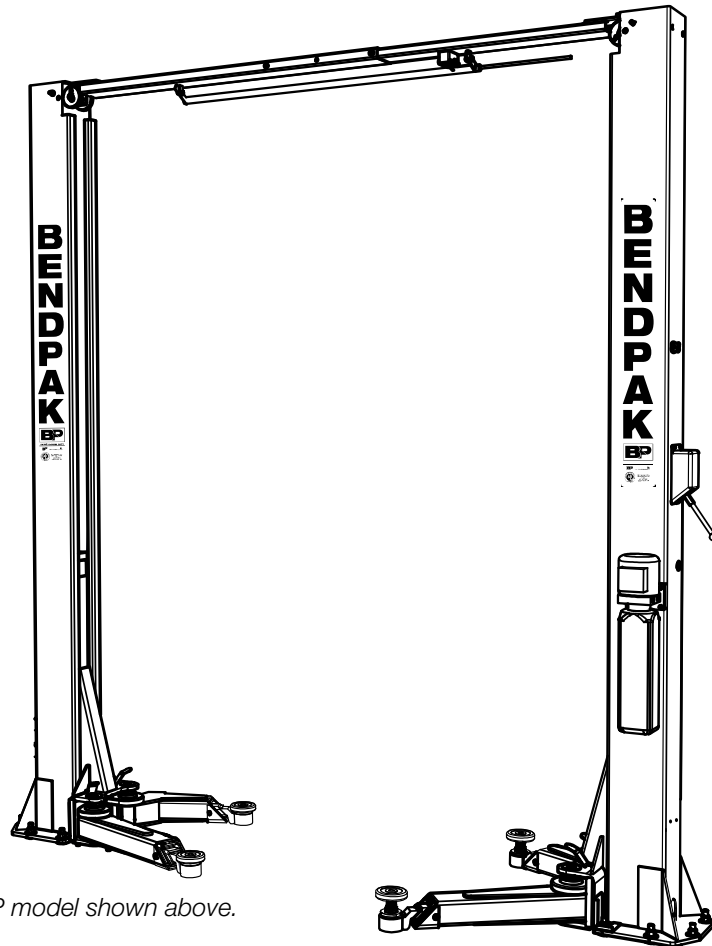
# Installation and Operation Manual

Manual P/N 5900265 — Manual Revision A10 — September 2023

Models:

- 10AP
- 10AP-168
- 10APX
- 10APX-181

*Original instructions in  
the English language*



*10AP model shown above.*

**Designed and engineered by BendPak Inc. in Southern California, USA. Made in China.**

 **DANGER**

**IMPORTANT Safety Instructions, save these instructions! Read the *entire contents* of this manual *before* using this product. Failure to follow the instructions and safety precautions in this manual can result in severe injury or death. Make sure all other operators also read this manual. Keep the manual near the product for future reference. *By proceeding with setup and operation, you agree that you fully understand the contents of this manual and assume full responsibility for product use.***

**Manual.** 10AP Series Two-Post Lifts, *Installation and Operation Manual*, Manual Part Number 5900265, Manual Revision A10, released September 2023.

**Copyright.** Copyright ©2023 by BendPak Inc. All rights reserved. You may make copies of this document if you agree that: full attribution goes to BendPak Inc., you are not authorized to make changes to the content, you do not gain any rights to this content, and you will not use the copies for commercial purposes.

**Trademarks.** BendPak and the BendPak logo are registered trademarks of BendPak Inc. All other company, product, and service names are used for identification only. All trademarks and registered trademarks mentioned in this manual are the property of their respective owners.

**Limitations.** Every effort has been made to ensure complete and accurate instructions are included in this manual. However, product updates, revisions, and/or changes may have occurred since this manual was published. BendPak reserves the right to change any information in this manual without incurring any obligation for equipment previously or subsequently sold. All drawings are reference only – do not scale. BendPak is not responsible for typographical errors in this manual. You can always find the latest version of the **manual for your product on the BendPak website.**



SCAN FOR  
DIGITAL PDF

**Warranty.** The BendPak warranty is more than a commitment to you: it is also a commitment to the value of your new product. Contact your nearest BendPak dealer or visit [www.bendpak.com/support/warranty](http://www.bendpak.com/support/warranty) for full warranty details. Go to [bendpak.com/support/register-your-product/](http://bendpak.com/support/register-your-product/) and fill out the online form to register your product (be sure to click **Submit**).

**Safety.** Your Lift was designed and manufactured with safety in mind. Your safety also depends on proper training and thoughtful operation. Do not set up, operate, maintain, or repair the Lift without reading and understanding this manual and the labels on the unit; **do not use your Lift unless you can do so safely!**

**Owner Responsibility.** In order to maintain your product properly and to ensure operator safety, it is the responsibility of the product owner to read and follow these instructions:

- Follow all installation, operation, and maintenance instructions.
- Make sure product installation conforms to all applicable local, state, and federal codes, rules, and regulations, such as state and federal OSHA regulations and electrical codes.
- Read and follow all safety instructions. Keep them readily available for operators.
- Make sure all operators are properly trained, know how to safely operate the unit, and are properly supervised.
- Do not operate the product until you are certain all parts are in place and operating correctly.
- Carefully inspect the product on a regular basis and perform all maintenance as required.
- Service and maintain the unit only with approved replacement parts.
- Keep the manual with the product and make sure all labels are clean and visible.
- **BendPak** makes no promises, guarantees or assurances that our products meet any state, county, federal or international mandated permit, license, code, standard, certification, or any other mandate other than what is listed or shown on BendPak website(s), or any BendPak or Ranger online or published catalog. Not all BendPak Lift models meet the standards as prescribed by ANSI/ALI ALCTV-(current edition) or ANSI/UL 201. Consult [www.autolift.org](http://www.autolift.org) for a complete list of Lift models that meet ANSI/ALI ALCTV-(current edition) or ANSI/UL 201, or contact BendPak via [contact@bendpak.com](mailto:contact@bendpak.com). **Buyer assumes full responsibility for any state, county, federal or international mandated permit, license, code, standard, certification, or any other mandate required related to the installation and/or operation of any BendPak product.** BendPak will not be responsible for any charges, fines, liens, or other levies imposed on the Buyer related to any special or regional structural, seismic or any other building code and/or codes such as the Uniform Building Code (UBC), International Building Code (IBC), or any other state, county, federal or international mandated permit, license, code, standard, certification, or other mandate, law, rule, regulation or directive by any other agency, government, administrations, or corporations whether state, county, federal, or international mandated.

**Only use the Lift if it can be used safely!**

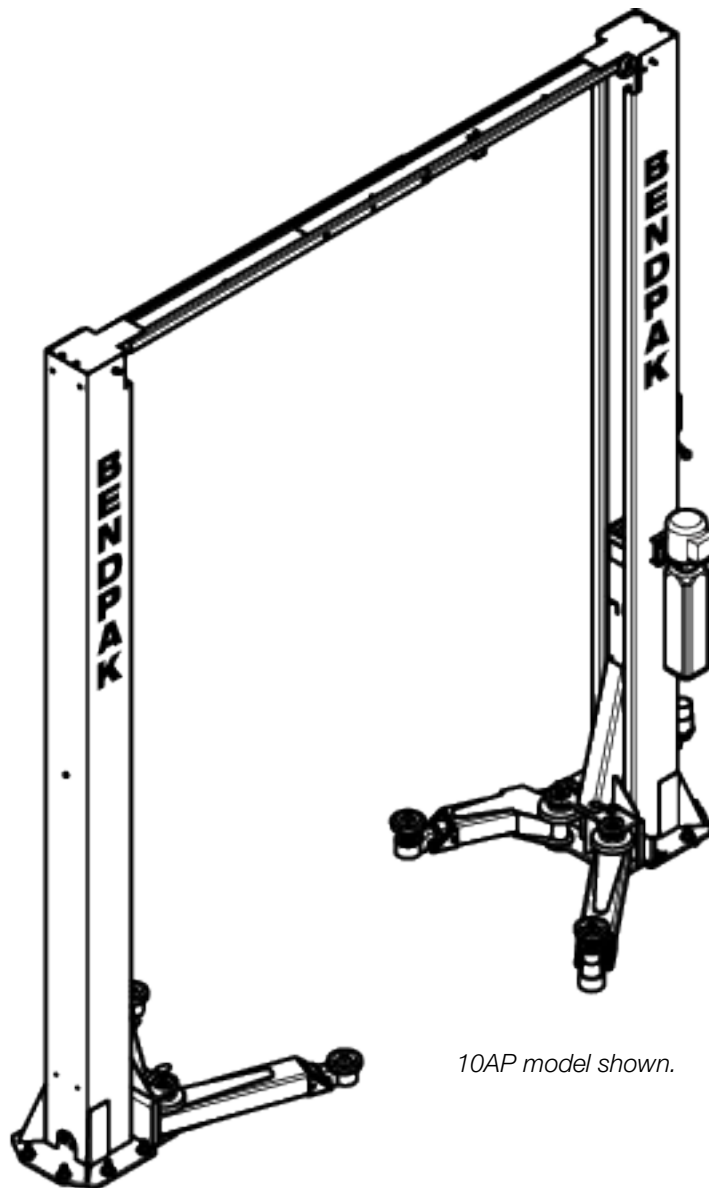
**Unit Information.** Enter the Model Number, Serial Number, and the Date of Manufacture from the ID label on your unit. This information is required for part or warranty issues.

Model: \_\_\_\_\_

Serial: \_\_\_\_\_

Date of Manufacture: \_\_\_\_\_

<b>BP BendPak.</b> Santa Paula, CA USA www.bendpak.com	
MODEL NUMBER	
DESCRIPTION	
LIFT CAPACITY	DATE CODE
VOLTAGE	
<input type="checkbox"/> 110-120V, 50-60 Hz, 1 Ph	
<input type="checkbox"/> 208-240V, 50-60 Hz, 1 Ph	
<input type="checkbox"/> 380-415V, 50-60 Hz, 3 Ph	
<input type="checkbox"/> 208-440V, 50-60 Hz, 3 Ph	
SERIAL NUMBER	
UPC	
<b>DANGER!</b> Disconnect Power Before Servicing	
MADE IN CHINA	WARRANTY VOID IF DATA PLATE IS REMOVED
CE EAC	
PN 5902550	



10AP model shown.

# Table of Contents

<b>Introduction</b> .....	<b>4</b>	<b>Maintenance</b> .....	<b>69</b>
<b>Shipping Information</b> .....	<b>5</b>	<b>Troubleshooting</b> .....	<b>71</b>
<b>Safety Considerations</b> .....	<b>5</b>	<b>Wiring Diagrams</b> .....	<b>75</b>
<b>Components</b> .....	<b>8</b>	<b>Labels</b> .....	<b>77</b>
<b>Specifications</b> .....	<b>9</b>	<b>Parts Drawings</b> .....	<b>80</b>
<b>Installation Checklist</b> .....	<b>11</b>	<b>ALI Store</b> .....	<b>97</b>
<b>Installation</b> .....	<b>12</b>	<b>Maintenance Log</b> .....	<b>98</b>
<b>Operation</b> .....	<b>59</b>		

## Introduction

This manual describes the four BendPak Two-Post Lift models:

- **10AP.** A Two-Post Lift with overall height of 145 in. / 3,683 mm that raises Vehicles up to 10,000 pounds (4,536 kg).
- **10AP-168.** A taller version of the 10AP with overall height of 168 in. / 4,267 mm, designed to accommodate taller Vehicles.
- **10APX.** A Two-Post Lift with overall height of 157 in. / 3,988 mm that raises Vehicles up to 10,000 pounds (4,536 kg).
- **10APX-181.** A taller version of the 10APX with overall height of 181 in. / 4,597 mm, designed to accommodate taller Vehicles.

*All models have Overhead Assemblies and clear floors. All models may be adjusted to a narrow 92-inch (2,337 mm) or a wide 102-inch (2,591 mm) drive-through dimension.*

**⚠ DANGER** Be very careful when installing, operating, maintaining, or repairing this equipment; failure to do so could result in property damage, product damage, injury, or (in very rare cases) death. Make sure only authorized personnel operate this equipment. All repairs must be performed by an authorized technician. Do not make modifications to the unit; this voids the warranty and increases the chances of injury or property damage. Make sure to read and follow the instructions on the labels on the unit.

**This manual is mandatory reading for all users** of 10AP Series Two-Post Lifts, including anyone who installs, operates, maintains, or repairs them. Always keep this manual on or near the equipment.

Technical support and service is available from your dealer, on the Web at [bendpak.com/support](https://bendpak.com/support), by email at [support@bendpak.com](mailto:support@bendpak.com), or by phone at **(800) 253-2363**, option 7 then 4.

Online chat is also available at [www.bendpak.com](https://www.bendpak.com) click the chat icon.



Scan this QR Code for up-to-date information and videos on the 10AP Lift series.



SCAN FOR VIDEO

---

# Shipping Information

Your equipment was carefully checked before shipping. Nevertheless, you should thoroughly inspect the shipment **before** you sign to acknowledge that you received it.


When you sign the bill of lading, it tells the carrier that the items on the invoice were received in good condition. **Do not sign the bill of lading until after you have inspected the shipment.** If any of the items listed on the bill of lading are missing or damaged, do not accept the shipment until the carrier makes a notation on the bill of lading that lists the missing or damaged goods.

If you discover missing or damaged goods **after** you receive the shipment and have signed the bill of lading, notify the carrier at once and request the carrier to make an inspection. If the carrier will not make an inspection, prepare a signed statement to the effect that you have notified the carrier (on a specific date) and that the carrier has failed to comply with your request.

It is difficult to collect for loss or damage after you have given the carrier a signed bill of lading. If this happens to you, file a claim with the carrier promptly. Support your claim with copies of the bill of lading, freight bill, invoice, and photographs, if available. Our willingness to assist in helping you process your claim does not make us responsible for collection of claims or replacement of lost or damaged materials.

## Safety Considerations

**Read this entire manual carefully before using your new product.** Do not install or operate the product until you are familiar with all operating instructions and warnings. Do not allow anyone else to operate the product until they are familiar with all operating instructions and warnings.

 **WARNING California Proposition 65.** This product can expose you to chemicals including styrene and vinyl chloride which are on the list of over 900 chemicals identified by the State of California to cause cancer, birth defects or reproductive harm. Always use this product in accordance with BendPak's instructions. For more information, visit [www.p65warnings.ca.gov](http://www.p65warnings.ca.gov).

### Important Safety Information

When using this equipment, basic safety precautions should always be followed, including:

- Read all instructions. Use only as described in this manual.
- Only operate your Lift between temperatures of 41°F to 104°F (5°C to 40°C).
- Make sure all operators read and understand this *Installation and Operation Manual*. **Keep the manual near the Lift at all times.** The Lift should only be operated by authorized personnel. Keep children and untrained personnel away from the Lift.
- BendPak recommends referring to the ANSI/ALI ALIS Standard *Safety Requirements for Installation and Service* for more information about safely installing, using, and servicing your Lift.
- The Lift should only be operated by authorized personnel. Keep children and untrained personnel away from the Lift.
- Do not make any modifications to the Lift; this voids the warranty and increases the chances of injury or property damage. Use only factory-approved attachments.
- Do not use the Lift while tired or under the influence of drugs, alcohol, or medication.
- Do not touch hot parts; you could be burned. Always use care with the equipment.

- 
- Do not operate equipment with a damaged cord or if the equipment has been dropped or damaged – until it has been examined by a qualified service person.
  - Do not let a cord hang over the edge of a table, bench, or counter or come in contact with hot manifolds or moving fan blades. Loop the power cord around equipment when storing.
  - If an extension cord is necessary, a cord with a current rating equal to or greater than that of the equipment should be used. Cords rated for less current than the equipment may overheat. Care should be taken to arrange the cord so that it will not be tripped over or pulled out.
  - Always unplug equipment from electrical outlets when not in use. Never use the cord to pull the plug from the outlet. Grasp plug and pull to disconnect.
  - To reduce the risk of a fire, do not operate equipment in the vicinity of open containers of flammable liquids (like gasoline).
  - Adequate ventilation should be provided when working on operating internal combustion engines.
  - Keep hair, loose clothing, fingers, and all parts of the body away from moving parts.
  - To reduce the risk of electric shock, do not use the unit on wet surfaces or expose to rain.
  - **Always wear safety glasses!** Everyday glasses only have impact resistant lenses, they are not safety glasses.

**Save these instructions!**

## **Additional Safety Information**

The following safety information applies to all BendPak 10AP models:

- 10AP Series Lifts are Two Post Service Lifts. **Use them only for their intended purpose.**
- You must wear OSHA-approved (publication 3151) personal protective equipment **at all times** when installing, using, maintaining, or repairing the Lift. Leather gloves, steel-toed work boots, eye protection, back belts, and hearing protection are **mandatory**.
- **Never** exceed the rated capacity of the Lift.
- When the Lift is in use, keep hands and all body parts well away from it.
- Keep loads balanced on the Lift Arm Assemblies. Clear the area immediately if a Vehicle is in danger of falling off the Lift.
- Modifications void the warranty and increases the chances of injury or property damage. **Do not modify any safety-related features in any way.**
- The Lift uses electrical energy; if your organization has Lockout/Tagout policies, make sure to implement them after connecting the Lift to a power source.
- When handling the Hydraulic components, **always wear safety gloves!** In rare cases, a needle-like stream of Hydraulic Fluid (even at low pressure) can penetrate fingers, hands, or arms. Such a puncture can feel like a bite, electric shock, or a prick. While it may seem like a minor issue, any amount of Hydraulic Fluid injected into the human body is a serious issue. Anyone suffering such a puncture wound should be **immediately** taken as an emergency to the hospital to determine the extent of the injury. Explain the circumstances of the injury to the attending physician, including what type of Hydraulic Fluid was involved. Do not assume a puncture wound that could have been caused by Hydraulic Fluid is a minor issue; it could be life-threatening.
- Make a visual inspection of the Lift before using it. Do not use the Lift if you find any missing or damaged parts. Instead, take it out of service, then contact an authorized repair facility, your distributor, or BendPak at **(805) 933-9970** or email [support@bendpak.com](mailto:support@bendpak.com).
- BendPak recommends making a **thorough** inspection of the Lift at least once a year. Replace any damaged or severely worn parts, decals, or warning labels.

---

## Symbols

Following are symbols used in this manual:



**DANGER**

Calls attention to a hazard that **will** result in death or injury.



**WARNING**

Calls attention to a hazard or unsafe practice that **could** result in death or injury.



**CAUTION**

Calls attention to a hazard or unsafe practice that could result in personal injury, product damage, or property damage.

**NOTICE**

Calls attention to a situation that could result in product or property damage.

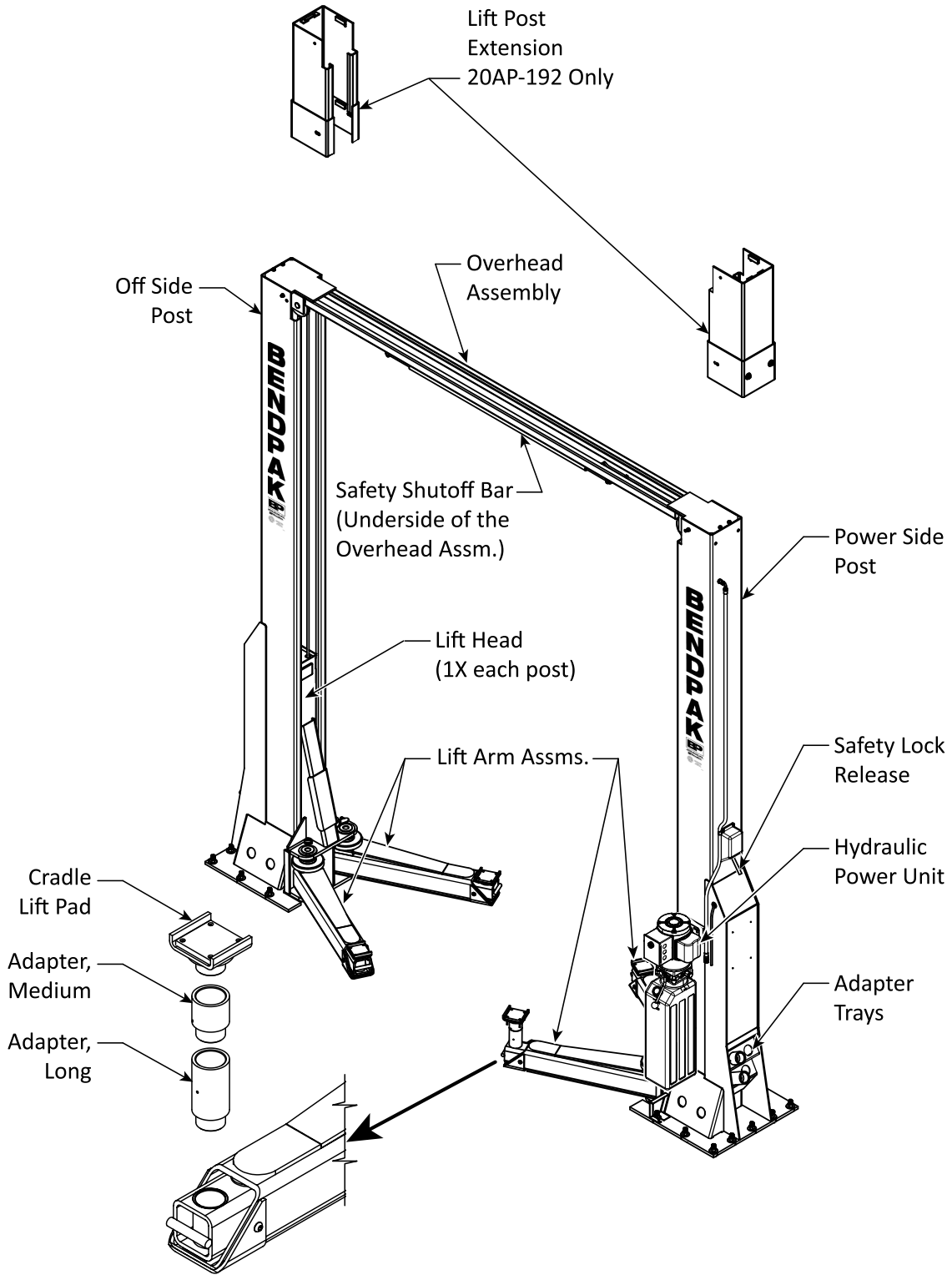
## Liability Information

BendPak assumes **no** liability for damages resulting from:

- Use of the equipment for purposes other than those described in this manual.
- Modifications to the equipment without prior, written permission from BendPak.
- Injury or death caused by modifying, disabling, overriding, or removing safety features.
- Damage to the equipment from external influences.
- Incorrect operation of the equipment.

# Components

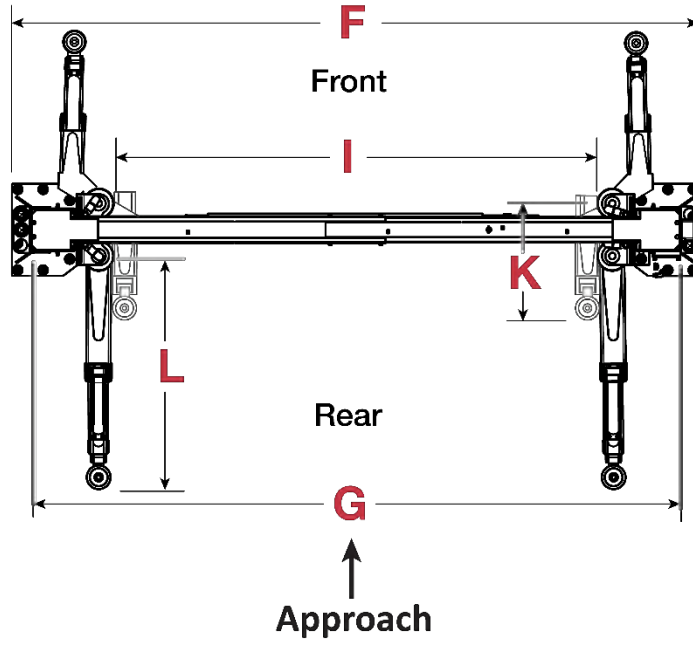
*Not all components shown. Models with extensions are taller. Reference only – do not scale.*



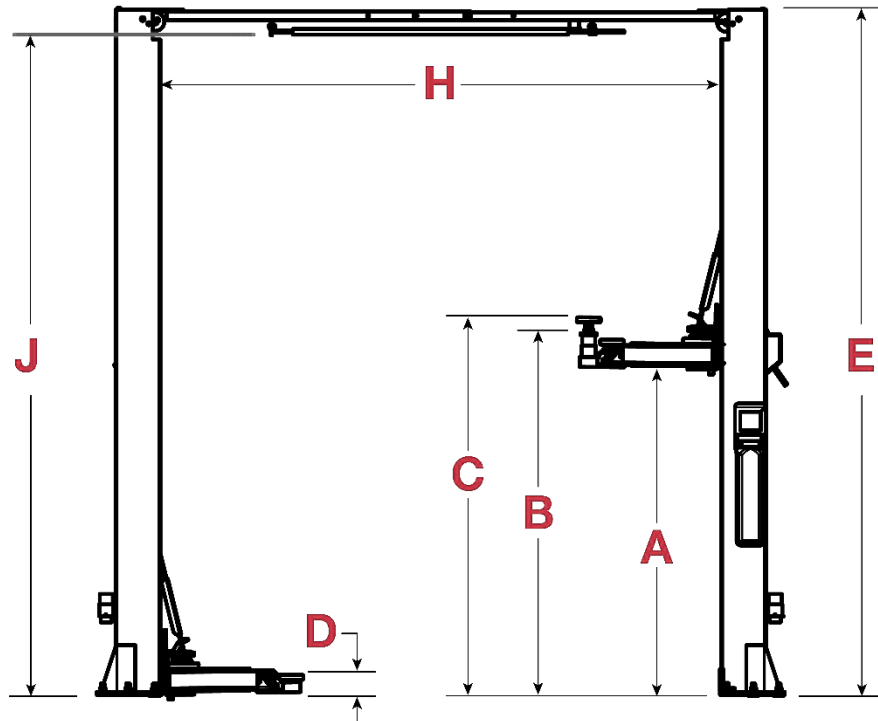


# Specifications

Top View



Approach View



*Reference only – do not scale. Shown with Optional Accessories.*

Model	10AP	10AP-168	10APX	10APX-181
Lifting Capacity	10,000 lbs. / 4,536 kg			
Max. Capacity — Front Axle	5,000 lbs. / 2,268 kg			
Max. Capacity — Rear Axle	5,000 lbs. / 2,268 kg			
<b>A</b> – Max. Rise	69 in. / 1,753 mm		75.5 in. / 1,918 mm	
<b>B</b> – Lifting Height w/ Pad <sup>1</sup>	73 in. / 1,854 mm		79.5 in. / 2,007 mm	
<b>C</b> – Max. Lifting Height <sup>1</sup>	82.5 in. / 2,095 mm		89 in. / 2,261 mm	
<b>D</b> – Min. Height w/ Pad	4 in. / 102 mm			
<b>E</b> – Overall Height	145 in. / 3,683 mm	168 in. / 4,267 mm	157 in. / 3,988 mm	181 in. / 4,597 mm
<b>F</b> – Width Overall (Narrow)	135 in. / 3,431 mm			
<b>F</b> – Width Overall (Wide)	145 in. / 3,683 mm			
<b>G</b> – Outside Posts (Narrow)	127.5 in. / 3,238 mm			
<b>G</b> – Outside Posts (Wide)	137.5 in. / 3,492 mm			
<b>H</b> – Inside Posts (Narrow)	108.5 in. / 2,756 mm			
<b>H</b> – Inside Posts (Wide)	118.5 in. / 3,010 mm			
<b>I</b> – Drive-Thru Width (Narrow)	92 in. / 2,338 mm			
<b>I</b> – Drive-Thru Width (Wide)	102 in. / 2,592 mm			
<b>J</b> – Floor to Top Switch	139.5 in. / 3,540 mm	163.5 in. / 4,155 mm	151.5 in. / 3,850 mm	175.75 in. / 4,464 mm
<b>K</b> – Front Arm Reach (min)	24.5 in. / 622 mm			
<b>K</b> – Front Arm Reach (max)	50 in. / 1,270 mm			
<b>L</b> – Rear Arm Reach (min)	32 in. / 812 mm			
<b>L</b> – Rear Arm Reach (max)	59.25 in. / 1,504 mm			
Max. load per Lift Arm	2,500 lbs. / 1,134 kg			
Screw Pad Adjustment	2 in. / 51 mm			
Time to Full Rise	≈ 45 seconds			
Motor <sup>2</sup>	220 VAC, 60 Hz, 1 Phase			
Sound	<70 dB			

<sup>1</sup>Lifting Height w/Pad is maximum lifting height with Pads adjusted to the lowest setting and no adapter(s). Maximum Lifting Height is maximum lifting height with Pads adjusted to high setting and with both tall and medium Adapters (optional equipment) installed.

<sup>2</sup>Special voltages available upon request.

<sup>3</sup>Lift Arms measured from the pivot center to the end of the Lift Arm.

**Specifications subject to change without notice.**

---

# Installation Checklist

Following are the steps needed to install a 10AP Series Two-Post Lift; perform them in this order.

- 1. Review the Safety Rules.
- 2. Make sure you have the necessary tools.
- 3. Plan for Electrical Work.
- 4. Review the Installation Orientation.
- 5. Review Clearances around the Lift.
- 6. Select the Installation Location.
- 7. Choose a Wide or Narrow Configuration (**do not proceed until you have chosen**).
- 8. Install the Safety Assemblies and position the Safety Cable.
- 9. Put Equalizing Cables into position.
- 10. Add Extension Pieces (10AP-168 or 10AP-181 Models only).
- 11. Learn about Hydraulic Fluid contamination.
- 12. Learn about Liquid Thread Sealant.
- 13. Routing the Hydraulic Hoses.
- 14. Create Chalk Line Guides for the Posts.
- 15. Anchor the Posts.
- 16. Prepare and install the Overhead Assembly and Safety Shutoff Bar.
- 17. Install the Microswitch.
- 18. Install the Equalizing Cables.
- 19. Mount the Power Unit (*but do not connect it to power yet*).
- 20. Route and install the Safety Lock Cable.
- 21. Connect the Hydraulic Hoses.
- 22. Install the Lift Arm Assemblies.
- 23. Perform final Leveling.
- 24. Contact the Electrician.
- 25. Wire the Microswitch (**Electrician required**).
- 26. Connect the Power Unit (**Electrician required**).
- 27. Install the Power Disconnect Switch and Thermal Disconnect Switch (**Electrician required**).
- 28. Lubricate the Lift.
- 29. Perform an Operational Test.
- 30. Review the Final Checklist.
- 31. Leave the Manual at the Lift for the Owner/Operator.

---


# Installation

The installation process includes multiple steps. Perform them in the order listed.


 **WARNING** Use only the factory-supplied parts shipped with your Lift. If you use attachments, accessories, or configuration modifying components that are in the path and/or affect the operation of the equipment, affect the equipment's electrical listing, or affect the intended Vehicle accommodation, and if they are not certified for use with this Lift, then you void the warranty of the Lift as well as compromising the safety of everyone who sets up or uses the Lift. If you are missing parts, visit [BendPak.com/Support](https://www.bendpak.com/Support), email [support@bendpak.com](mailto:support@bendpak.com) or contact BendPak technical support by phone at **(800) 253-2363**, option 7 then 4. Online chat is also available at [www.bendpak.com](https://www.bendpak.com) click the chat icon. 

## Reviewing the Safety Rules

When installing a Lift, your safety depends on proper training and thoughtful operation. BendPak recommends referring to the ANSI/ALI ALIS Standard *Safety Requirements for Installation and Service* for more information about safely installing, using, and servicing your Lift.

 **WARNING** Do not install this equipment unless you have automotive lift installation training. Always use proper lifting tools, such as a Forklift or Shop Crane, to raise heavy components. Do not install this equipment without reading and understanding this Manual and the Labels on the unit.

Only fully trained personnel should be involved in installing this equipment. Always pay attention. Use appropriate tools and lifting equipment. Stay clear of moving parts.

 **WARNING** You must always wear appropriate protective equipment during installation: leather gloves, steel-toed work boots, eye protection, back belts, and hearing protection.

## Gathering Your Tools

You may need some or all of the following tools:

- Rotary hammer drill (or similar)
- 3/4-inch carbide bit (conforming to ANSI B212.15)
- Hammer
- Four-foot level
- Open-end wrench set, SAE, and metric
- Socket and ratchet set, SAE, and metric
- Hex-key wrench set
- Crescent and pipe wrenches
- Crowbar
- Chalk line
- Medium-sized flat screwdriver
- Tape measure, 25 feet or more
- Needle-nose pliers
- Forklift or Shop Crane
- Two 12-foot ladders
- Two sawhorses
- Torque wrench

---

## Preparing for Electrical Work

You will need to have a licensed, certified Electrician available at some point during the installation.

**⚠ DANGER** All wiring **must** be performed by a licensed, certified Electrician in accordance with applicable local, state, and federal electrical codes, rules, and regulations, such as state and federal OSHA regulations and electrical codes.

**NOTICE** Notify your Electrician in advance so they come prepared with the items required to connect to the facility's power system, or an appropriate power cord with plug to connect to an appropriate VAC power source, a Power Disconnect Switch, and a Thermal Disconnect Switch. **These items are not supplied with the Lift.**

The Electrician needs to:

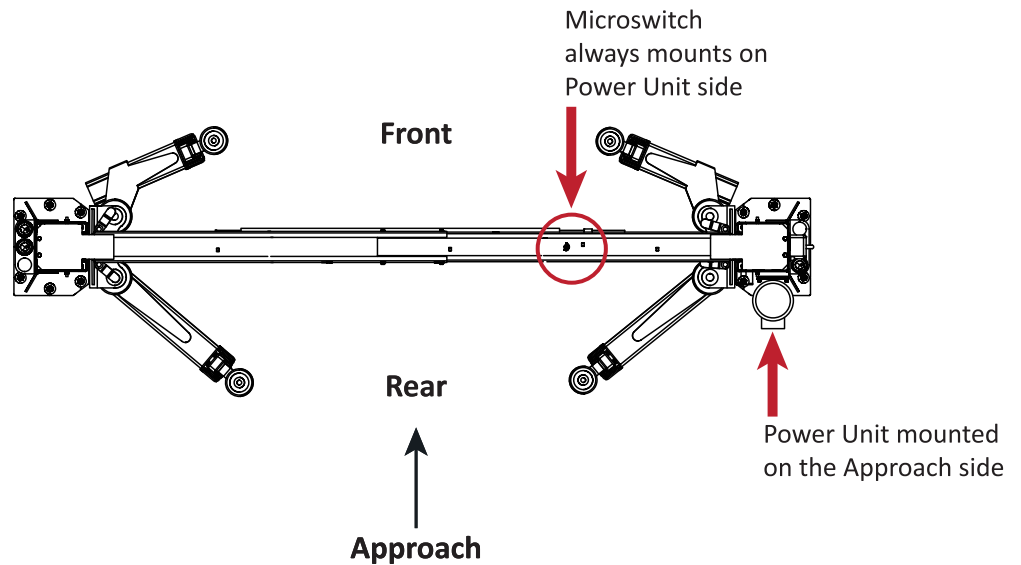
- **Connect to the VAC power source.** The Power Unit comes with a pigtail for wiring to a power source. Have your Electrician connect a power cord with plug to the electrical box on the Lift for connection to a power outlet or have them wire it directly into the electrical system at the Lift location. The Lift's Power Unit must be protected by an appropriate circuit breaker.
- **Connect the Microswitch wiring to the Power Unit.** The Microswitch must be wired to the Power Unit. The required wiring is included with the Lift.
- **Install a Power Disconnect Switch.** A Power Disconnect Switch is used to shut down the Lift in the event of an electrical circuit fault, emergency, or when the Lift is being serviced. Refer to [Installing a Power Disconnect Switch](#) for more information.
- **Install a Thermal Disconnect Switch.** A Thermal Disconnect Switch automatically shuts down the equipment in the event of an overload or an overheated motor. Refer to [Installing a Thermal Disconnect Switch](#) for more information.

## Reviewing the Installation Orientation

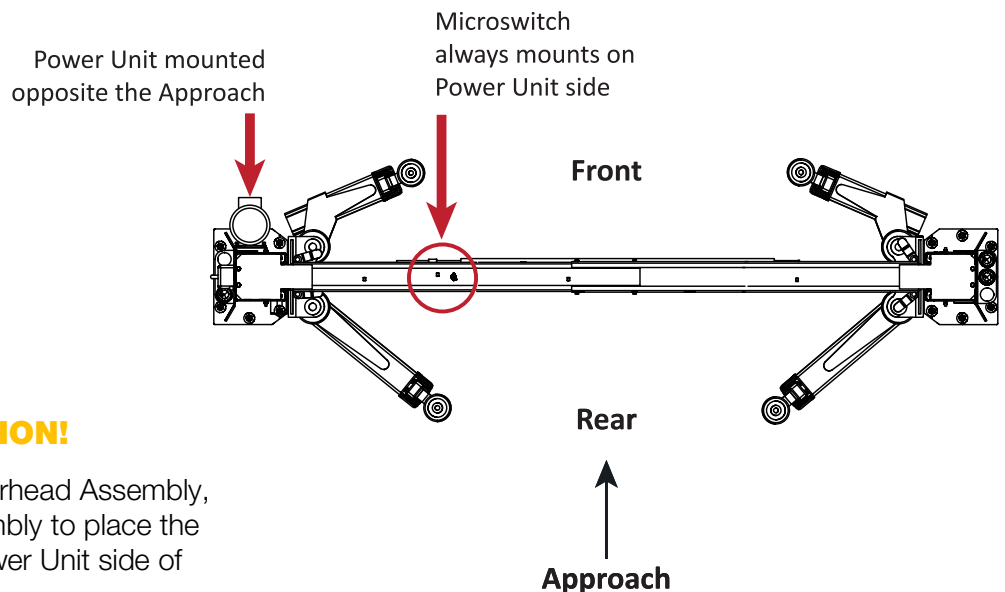
Keep these factors in mind when deciding how to orient the Lift:

- The first thing to figure out is which direction you will be driving the Vehicles in, called **the Approach**.
  - In most cases, this is simple: there's a driveway on one side and a wall on the other side. The driveway is your Approach. This makes the wall side the Front of the Lift and the driveway side the Rear of the Lift.
  - If both sides are open, decide which way you will be driving Vehicles onto the Lift. This is the Approach; the drive-**on** side is the Rear of the Lift and the drive-**off** side is the Front.
- While the Power Unit **must** be installed on the Powerside Post, that Powerside Post may be mounted on either side of the Lift. You can identify the Powerside Post by the Mounting Bracket to which the Power Unit attaches. Refer to the figures below.

### Top View Approach Side



### Top View Opposite Approach

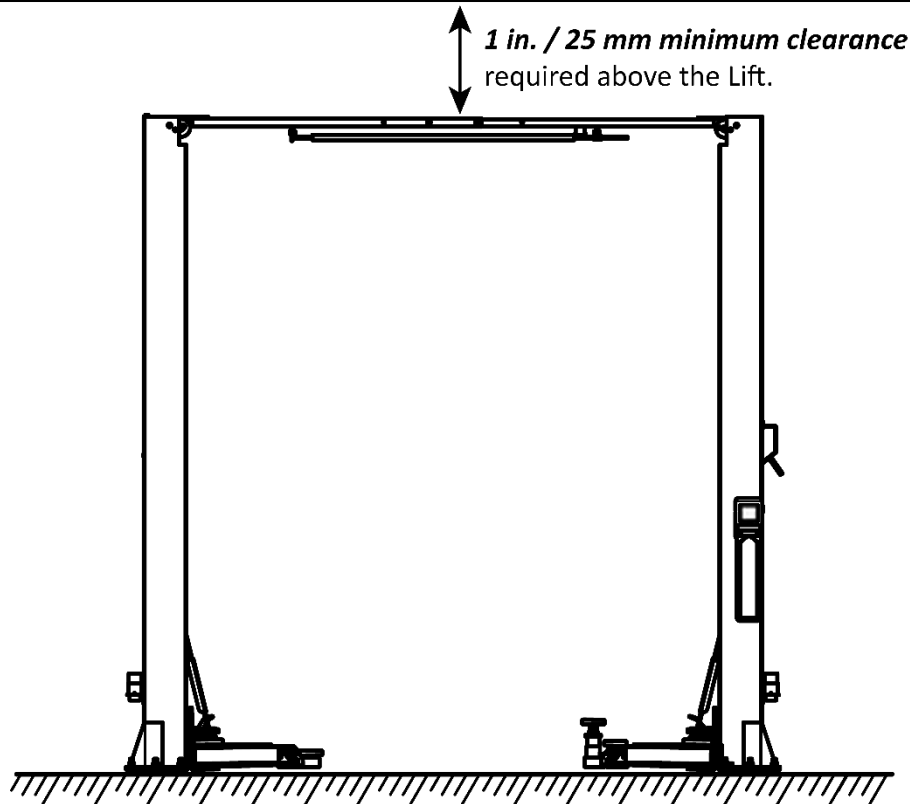
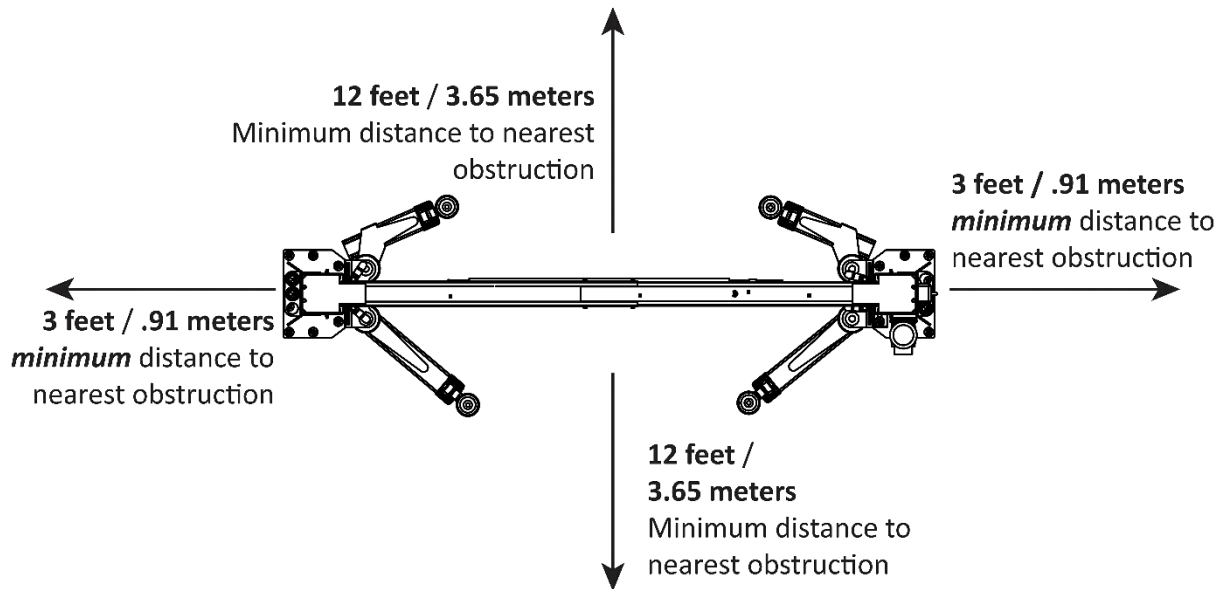


### ⚠ CAUTION!

When installing the Overhead Assembly, always orient the assembly to place the Microswitch on the Power Unit side of the Lift.

## Checking Clearances

Clearance around and above the Lift is **required for safety**. Refer to the figures below.




*Figures are not to scale, shown with optional accessories. Additional distance may be required on the Front and Rear to allow Vehicles to be driven in or out from these directions.*

---


## Selecting a Location

When selecting the location for your Lift, consider the following:


- **Architectural plans.** Consult the architectural plans for the desired location. Make sure there are no contradictions between what you want to do and what the plans show.
- **Available space.** Make sure there is enough space for the Lift: front, back, sides, and **above**. Refer to **Specifications** for exact measurements. Check for overhead obstructions such as building supports, heaters, lights, electrical lines, low ceilings, and so on.
- **Power.** You need an appropriate VAC power source for the Lift's Power Unit.
- **Outdoor installations.** 10AP Series Two-Post Lifts are approved for indoor installation and use only. **Outdoor installation is prohibited.**
- **Floor.** Only install the Lift on a flat, concrete floor; do not install on asphalt or any other surface. The surface must be level; do not install if the surface has a slope greater than or equal to 3°.

 **WARNING** Installing your Lift on a surface with more than three degrees of slope could lead to injury or even death. Only install your Lift on a level floor (defined as no more than 3/8 of an inch difference over the installation area). If your floor is not level, consider making the floor level or using a different location.


- **Concrete specifications.** The concrete must be a minimum 4.25 inches thick, 3,000 PSI minimum compressive strength, and cured for a minimum of 28 days. Do not install the Lift on cracked or defective concrete. Anchor Bolts must be more than 6 inches from cracks and expansion joints in the concrete or from a wall.

 **CAUTION** BendPak Lifts are supplied with installation instructions and concrete anchors that meet the criteria set by the latest version of the American National Standard in Automotive Lifts – Safety Requirements for Construction, Testing, and Validation in., ANSI/ALI ALCTV. Consult with an expert for any special regional structural and/or seismic anchoring requirements specified by any other agencies and/or codes such as the Uniform Building Code (UBC) and/or International Building Code (IBC).

Check your floor for the possibility of it being a post-tension slab. In this case, contact the building architect **before** drilling. Using ground penetrating radar may help you find tensioned steel.

 **WARNING** Cutting through a tensioned cable can result in injury or death. Do not drill into a post-tension slab unless the building architect confirms you are **not** going to hit tensioned steel, or you have located it using ground penetrating radar. **If colored sheath comes up while drilling, stop drilling immediately.**

- **Unloading the components.** Unload the Lift components as close to the installation location as possible. The Lift includes several heavy pieces, so the closer you unload them to the installation location, the better off you will be.

 **WARNING** Some Lift components are very heavy; if handled incorrectly, they can damage materials like tile, sandstone, and brick. Try to handle the Lift components just twice: once when delivered and once when moved into position. You must have a Forklift or Shop Crane to move some of the Lift components into position. **Use care when moving Lift components.**



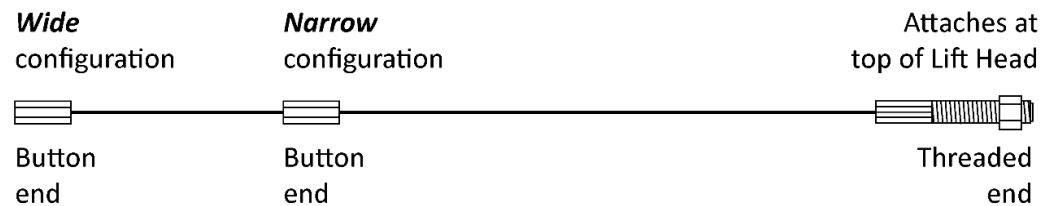
---

## Choosing a Wide or Narrow Configuration

10AP Series Two-Post Lifts can be installed in a Wide or Narrow Configuration:

- **Wide Configuration.** The Posts are farther apart, which means you can raise wider Vehicles on the Lift. This is usually the best choice **if** your Lift location is wide enough to support it. When installing the Equalizing Cables, use the Button End at the very end of the cable.

The following drawing shows an Equalizing Cable; the ends are exaggerated for clarity.



- **Narrow Configuration.** The Posts are closer together. This is usually the best choice for narrower garages, as it uses less width. When you are installing the Equalizing Cables, use the Button End **away** from the end of the cable.

**NOTICE** 10AP Series Lifts are shipped from the factory with the Overhead Assembly and the Safety Shutoff Bar *already configured in the Narrow Configuration*. Refer to **Installing the Overhead Assembly and Safety Shutoff Bar** for information about switching to the Wide Configuration.

You do not need to do anything to the Overhead Assembly at this point, but you must **decide** on a Wide or Narrow Configuration **now** for two reasons:

- **Routing the Equalizing Cables.** The Equalizing Cables come with two Button ends, one for the Wide Configuration and one for the Narrow Configuration. You need to know which Button end to use when you put the Equalizing Cables into position.
- **Creating the Chalk Line Guides.** You use the Overall Width setting (in **Specifications**) to create the Chalk Line Guides, so you know how far apart to put your Posts. There are two Width Overall settings, one for the Wide Configuration and one for the Narrow Configuration. You need to know which one to use when you are creating your Chalk Line Guides.

**NOTICE** If you are installing a Lift and do not yet know if it is going to be a Wide or a Narrow Configuration, you need to **figure it out now**, before you go any further in the installation process.

---

## Installing the Safety Assemblies and Positioning the Safety Lock Cable

Leaving both Lift Posts flat on the ground with access to the inside of the Post will ease the Safety Lock installation and threading of the Safety Lock Cable into position. This procedure is intended to leave the cable coiled at the top of the Offside Post, ready for routing after the Posts are standing. This position will also make it easier to put the Equalizing Cables into position.

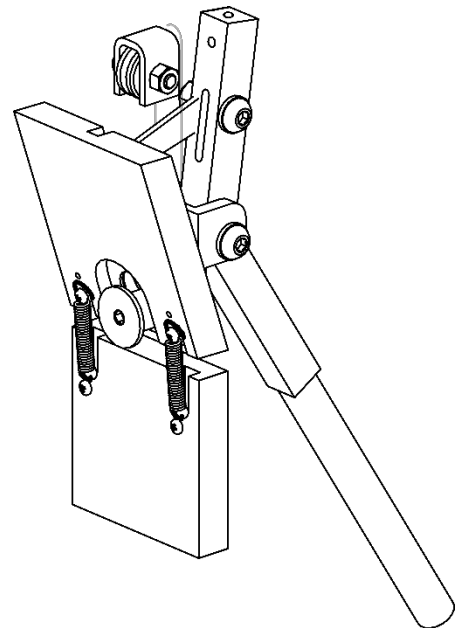
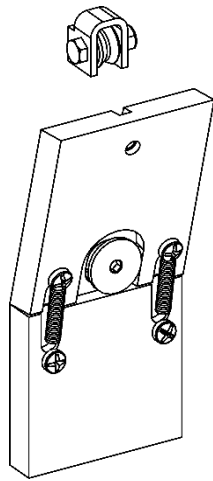
10AP Series Lifts have two Safety Assemblies: one on the Powerside Post (above the Power Unit) and the other on the Offside Post at the same height.

The two Safety Assemblies engage the Lift head and prevent it from lowering. The Safety Release mechanism allows the Lift Head to move past the Safety Locks and lower to the ground. The Safety Assemblies must be disengaged **at the same time** so that both Lift Heads lower together. To accomplish this, the two Safety Assemblies are connected to each other via a Safety Lock Cable, which is routed through the Lift Posts and the Overhead Assembly.

The following illustrations display the Offside and Powerside Safety Mechanisms.

**Offside Safety:** Similar to the Powerside Safety, except that it does not have a Safety Lock Release Handle.

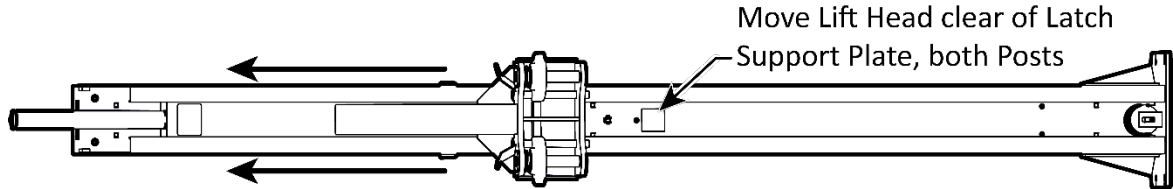
**Powerside Safety:** The Powerside Safety includes a Safety Lock Release Handle and spring, which is pushed down and used to disengage the Safety Locks when lowering the Lift.



*Not to scale. Components removed for clarity.*

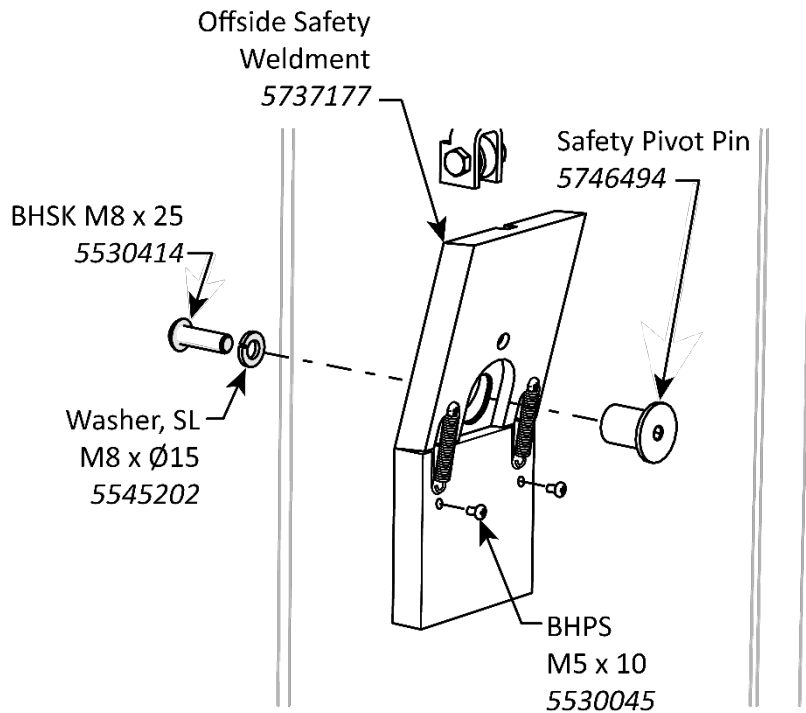
**To assemble and install the two Safety Assemblies and pre-position the safety release cable:**

1. Put both Posts either flat on the ground or elevated on a sawhorse or similar. The **insides** of the Posts must be accessible, facing up.
2. Slide the Lift Heads away from the bottom of both Posts. Far enough to clear the Latch Support Plate and provide room to work.

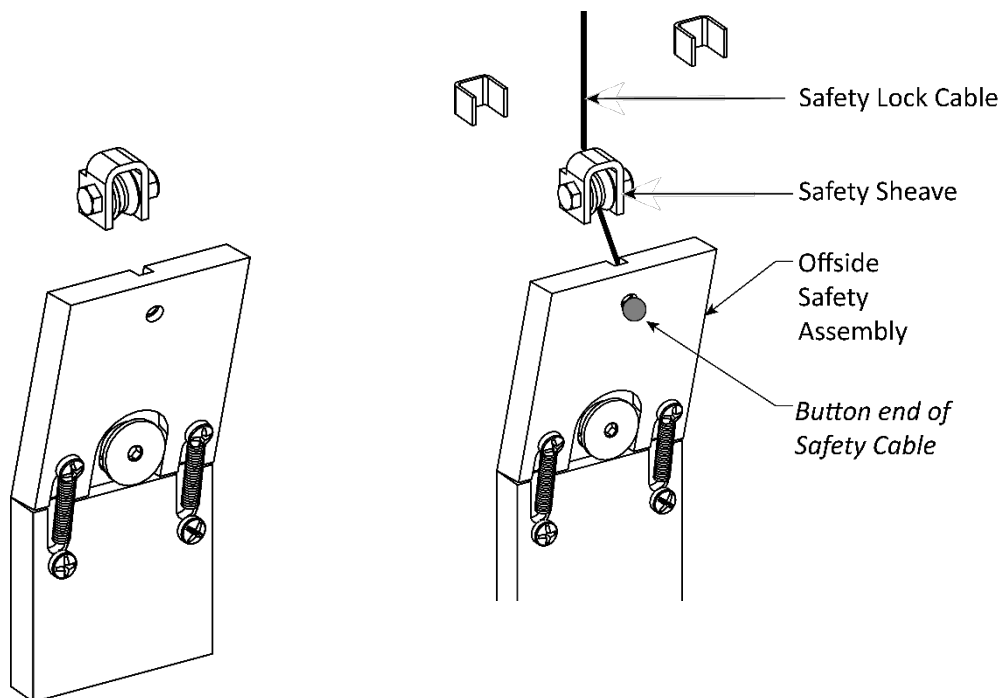


*Illustration above is a top view looking at the inside of the Lift Post. Not to Scale. Some components removed for clarity.*

3. **Begin on the Offside Post**, retrieve the Offside Safety Block (5737177), two extension springs (5540047), four M6 x 20 machine screws (5530065) and the Pivot Pin (5746494) from the Parts Bag. Overlap the Safety Block over the Latch Support Plate welded to the Offside Lift Post. Then attach the extension Springs. Overlapping these parts will ease the Extension Spring installation. Then move the Safety Block to overlap the Latch Support Plate and secure using the Safety Pivot Pin as shown below.



*Not to scale. Components removed for clarity.*



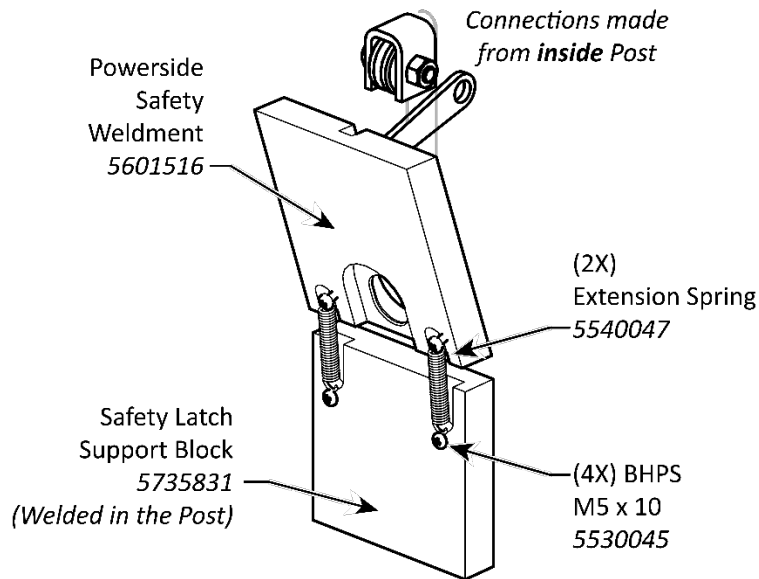
*Reference only – do not scale.*

4. Locate the Safety Lock Cable. This is a long, thin Wire Rope Cable with a Button swaged onto one end and nothing on the other end. Thread the cable through the Offside Safety Block as shown above. *Part Number and Cable length varies based on Lift Model.*

<b>Model</b>	<b>Part Number</b>	<b>Safety Cable Dia. and Length</b>
10AP	5595793	Ø1.8 x 7,773 mm
10AP-168	5595831	Ø1.8 x 8,865 mm
10APX	5595832	Ø1.8 x 8,103 mm
10AP-181	5595833	Ø1.8 x 9,322 mm

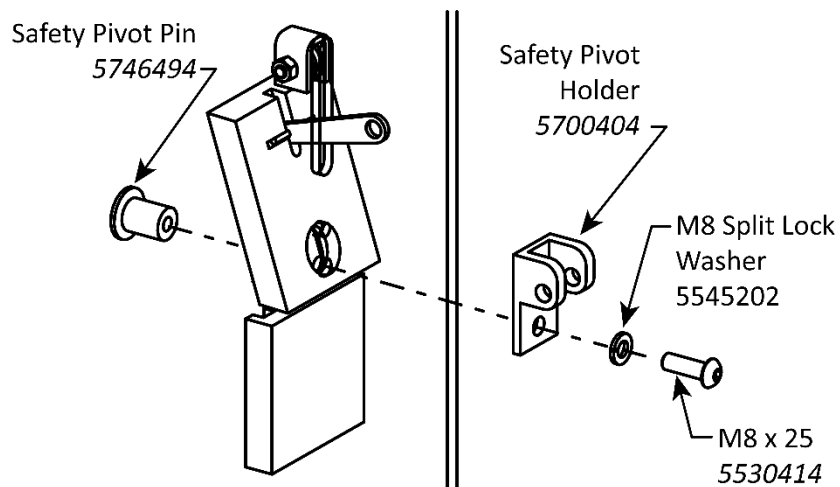
5. Thread the remainder of the Safety Lock Cable under the Safety Cable Sheave and Lift Head, then up to the top of the Offside Post. **Coil the cable and secure with tape or a Zip Tie at the top of the Offside Lift Post until called for later in the assembly.**

6. **Move to the Powerside Post**, Retrieve the Powerside Safety Weldment (5601516), the two extension springs (5540047) and four machine screws (5530045), then attach it over the Safety Latch Support Block that is welded inside the Post, as shown below. Attach the Safety Pivot Holder (5700404) to the Powerside Post, as depicted in step 7 below.

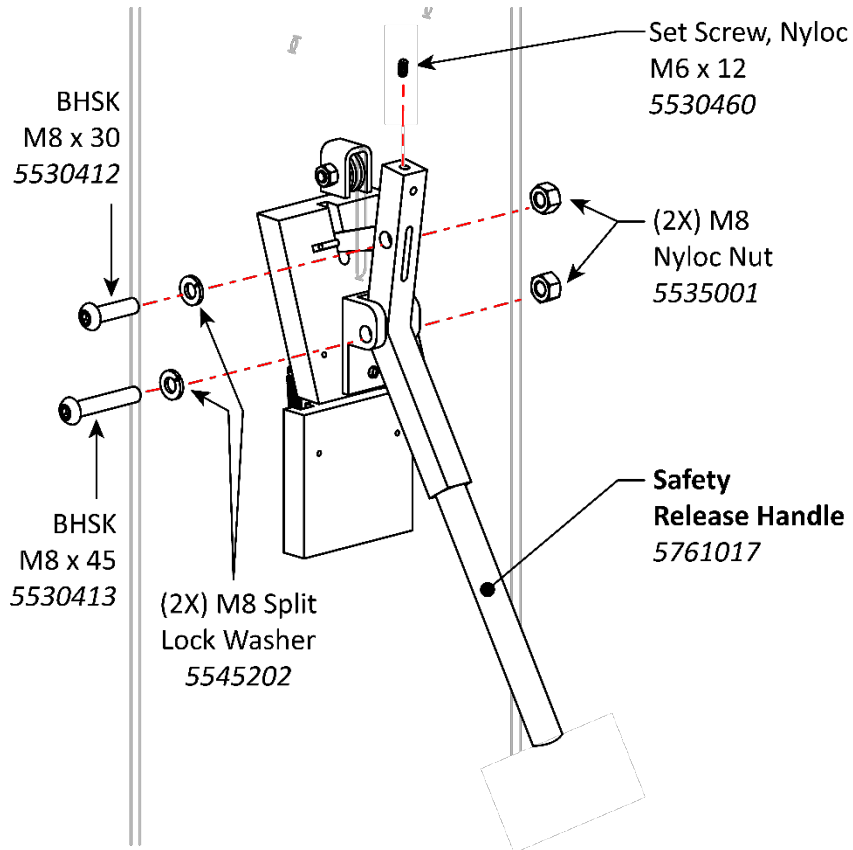


*Reference only – do not scale.*

7. Connect the Pivot Pin and Safety Pivot Holder using the M8 x 25 Machine Screw through the Powerside Post.



8. After the Safety Pivot Holder is in place, attach the Safety Release Handle (5761017) as depicted below.



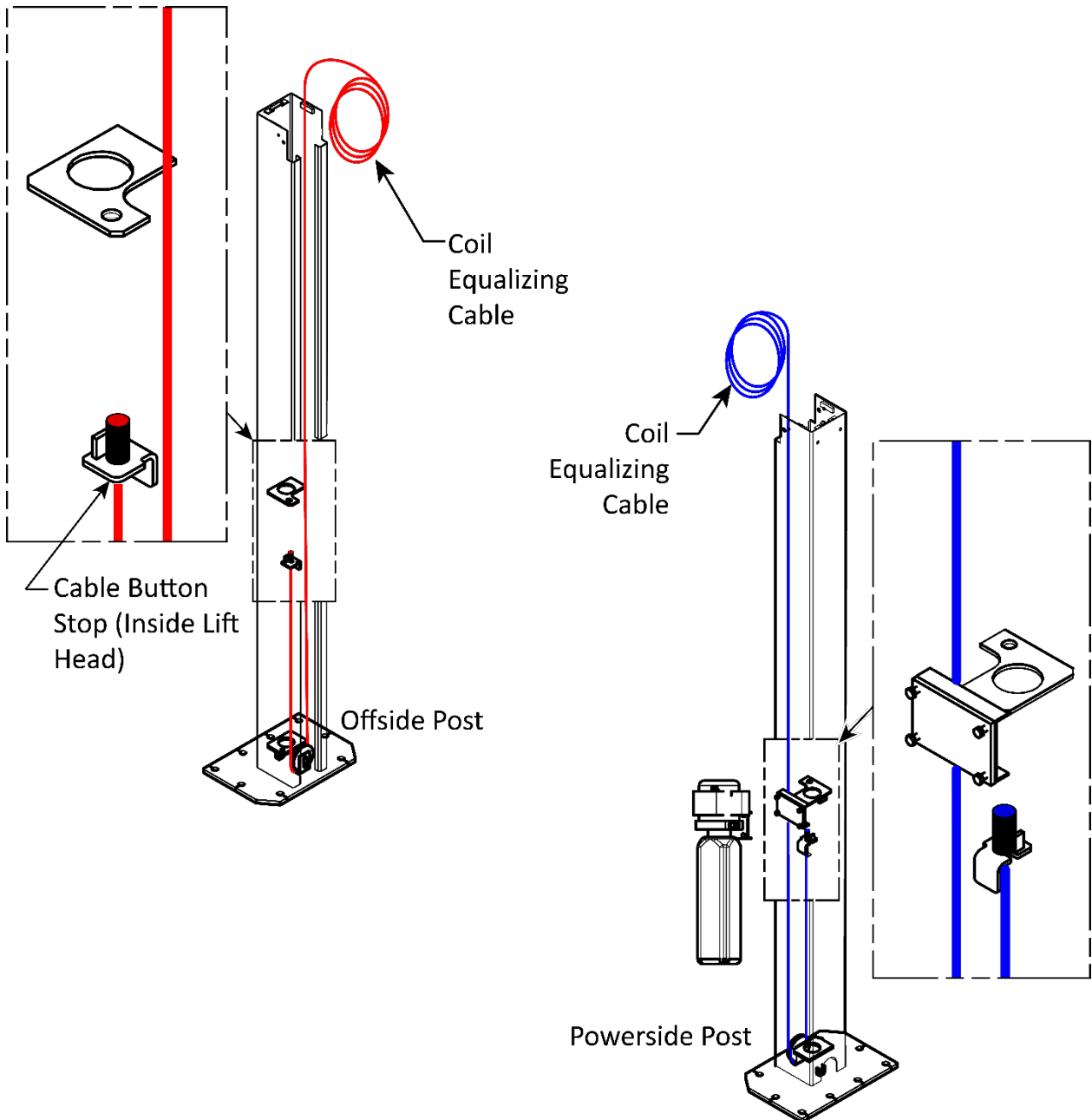
*Reference only – do not scale.*

## Putting the Equalizing Cables into Position

It is much easier to put the Equalizing Cables into position **before** you stand up the Posts. Note that this is not a full install of the Equalizing Cables, just putting them into position and looping the excess at the top of the Post secured with a Zip Tie or Tape.

**NOTICE** The two Equalizing Cables are the same length.

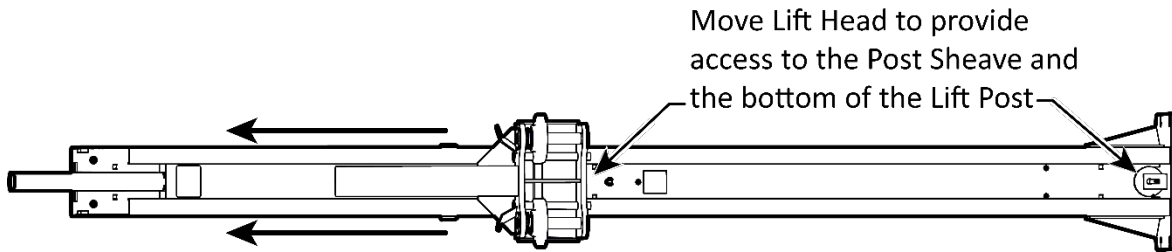
**CAUTION** BendPak recommends wearing safety gloves when handling the Equalizing Cables. The following graphic provides an overview of the Equalizer Cable routed into position.



*Not to scale, components removed for clarity.*

**To put the Equalizing Cables into position:**

1. Put both Posts either flat on the ground or elevated on a sawhorse or similar. The **insides** of the Posts must be accessible, facing up.
2. Slide the Lift Heads away from the bottom of both Posts. Far enough to provide access to the bottom of the Lift Post and the Post Sheave.

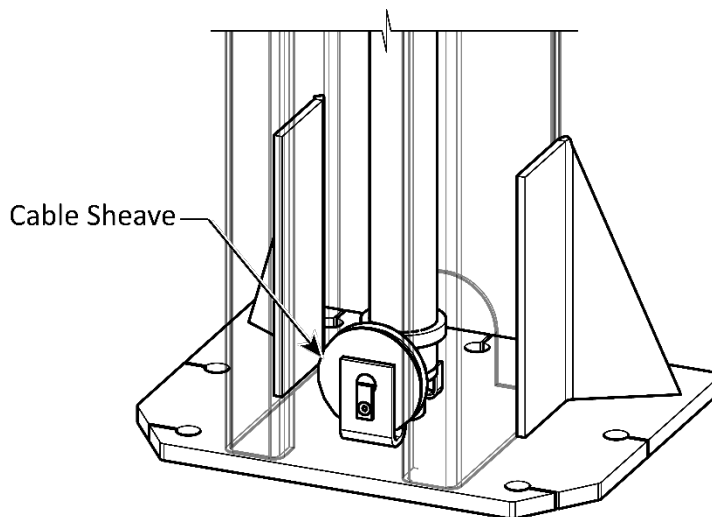


*Reference only – do not scale.*

3. Retrieve the two Equalizing Cables for your Lift. Each model has a specific Equalizing Cable length as noted in the table below.

<b>Model</b>	<b>Part Number</b>	<b>Equalizing Cable Assembly Dia. and Length</b>
10AP	5595752	Ø10 x 10,170 mm
10AP-168	5595753	Ø10 x 11,400 mm
10APX	5595754	Ø10 x 10,790 mm
10APX-181	5595755	Ø10 x 12,005 mm

4. Remove the Post Sheave from the bottom of both Posts.



*Illustration shows the Cable Sheave near the bottom of the Post.  
Reference only – do not scale.*

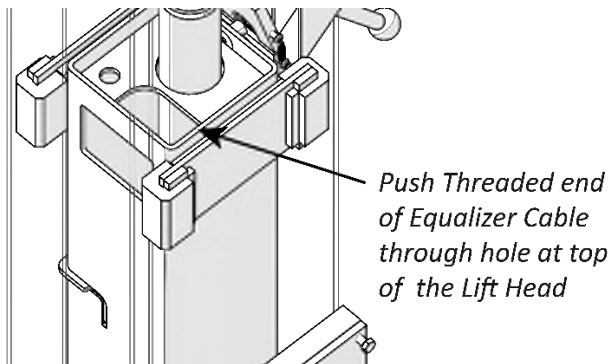
**NOTICE** Keep the Post Sheave, Sheave Pin, and Bolt nearby; you will be re-installing them soon.



- 
5. Take an Equalizing Cable and locate the Button End you are going to use:
    - For **Wide Configurations**, use the Button end at the very end of the cable.
    - For **Narrow Configurations**, use the Button end away from the end of the cable.
  6. Push the Button end up through the bottom of the Lift Head up towards the Cable Button Stop, then push the Button end into the Slot in the Cable Button Stop.

**Important** If you are having problems getting the Button end into the Slot, try pushing the Button end past the Button Stop and out the Hole at the Top of the Lift Plate; now, move the Equalizing Cable around to get the Cable into the Slot. Once the cable is in the Slot, pull back on the other end of the Cable to slide the Button end into the Slot. Try to keep the Cable taut until the Equalizing Cable is connected at the other end, done later in the installation. Note that it can be difficult to get the cable back into the Slot if it comes out.

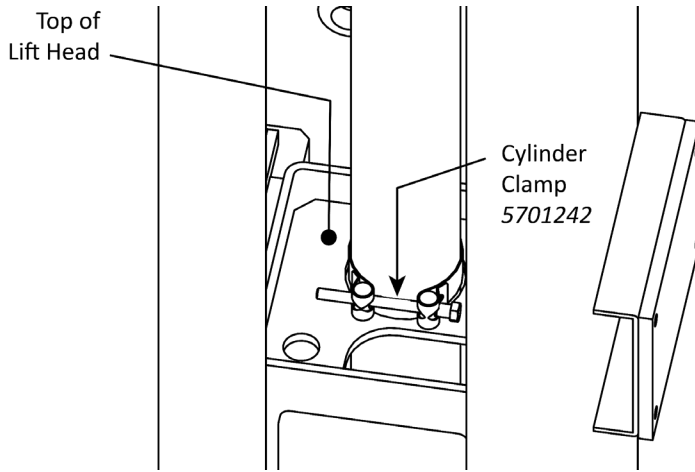
7. If you are using the Narrow configuration, bend the top of the Equalizing Cable so that it is out of the way of the other components in the Lift Head and Post.
8. Route the Equalizing Cable down to where the Post Sheave used to be and then up again towards the top of the Post.
9. Lubricate the Sheave Pin and Bearing with Red Lithium Grease, then replace the Post Sheave, making sure the Equalizing Cable is routed under it and in the Sheave.
10. Push the Threaded end of the Equalizing Cable through the Lift Head and out the Hole at the Top of the Lift Head.



*Illustration shows the opening in the Lift Head, which is where you route the Threaded end of the Equalizing Cable.*

*Not all components are shown. Reference only – do not scale.*

11. Coil up and bind the remainder of the Cable (the portion above the Hole at the Top of the Lift Head), then leave it resting on top of the Post until later in the installation.
12. Move both Lift Heads back down to the bottom of each Post.
13. Verify the Cylinder Clamps are in place on the Hydraulic Cylinders above the Lift Head.



Reference only – do not scale.

**⚠ WARNING** Verify the Cylinder Clamps are positioned at the top of the Lift Head and secured. **Do not operate the Lift if the Cylinder Clamps are not secured on the Hydraulic Cylinders.**

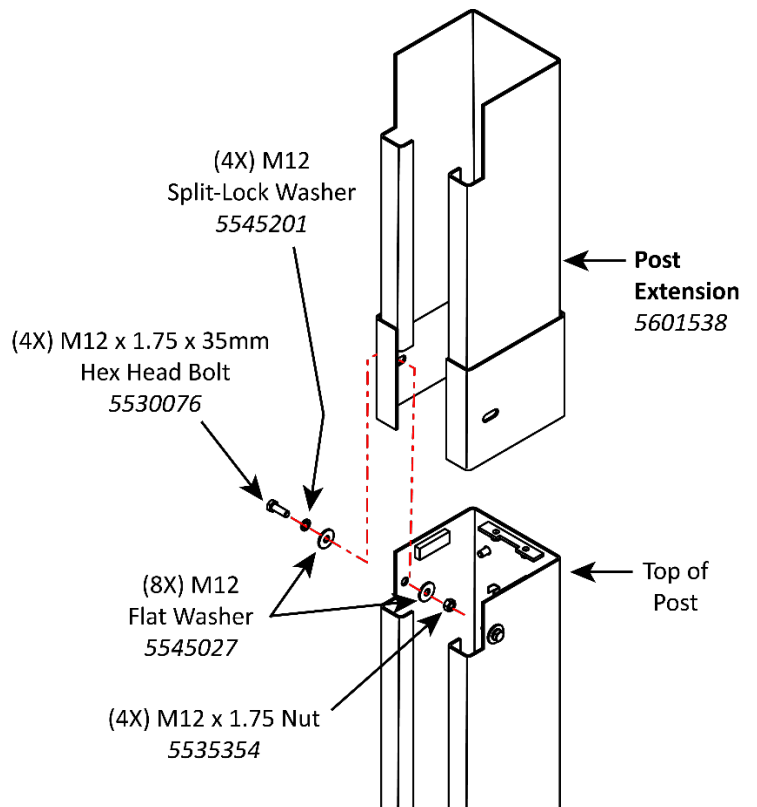
10AP Series model numbers ending with **-168** or **-181** are supplied with Post Extensions that raise the height of the Posts and allow you to raise taller Vehicles.

The Post Extensions are slipped over the top of both Posts and then bolted into place.

Reference only – do not scale.

**To install the Post Extensions:**

1. Locate the two Post Extensions and the 4 Hex Head Bolts, 8 Flat Washers, 4 Split-Lock Washers, and 4 Nuts. Reference the illustration above for part numbers.
2. Slide one of the Post Extensions over the top of one of the Posts.  
The opening in the Post Extension faces the inside of the Lift.
3. Secure the Post Extension to the Lift Post, using the hardware listed in the illustration above.
4. Slide on the other Post Extension to the other Lift Post and secure it the same way.





## IMPORTANT! PLEASE READ NOW



**Hydraulic Fluid Contamination poses a serious issue for your Lift;** contaminants such as water, dirt, or other debris can get into the Hydraulic Hoses and Fittings on the Lift, making your new Lift inoperable and unusable.

Your Lift is shipped with clean components; however, BendPak strongly recommends that you take secondary precautions and clean all Hydraulic Hoses and Fittings prior to making connections. It is better and less costly to take these extra steps now so that you do not need to take your Lift out of service later to fix issues that could have been prevented at the time of installation.

There are several ways to clean Hydraulic Hoses and Fittings:

- **Compressed Air.** Use an air compressor to blow out contaminants from each Hydraulic Hose and Fitting prior to installation. Clean, dry air is preferred. Wear ANSI-approved eye protection (safety glasses, goggles, or face shield) when using compressed air for cleaning. Never point an air hose nozzle at any part of your body or any other person.
- **Fluid Flushing.** If the Hydraulic Fluid is clean and compatible with the system fluid, you can flush Hoses and Fittings to create turbulent flow and remove particulates. Always ensure that the fluid itself is contaminant-free.

Some additional steps that will help keep the Hydraulic Fluid clean:

- **Remove old thread seal tape.** Some ports on the Hydraulic Cylinders are shipped with temporary plugs secured with thread seal tape, so make sure to thoroughly remove any leftover thread seal tape that may inadvertently enter the Hydraulic System.
- **Use a liquid thread sealant only.** Liquid thread sealant (Loctite™ 5452 or similar) is recommended. Do not use thread seal tape on any fitting. Liquid thread sealant is recommended for NPT connections, fine for JIC connections, but *not* necessary for O-ring (ORB) connections.
- **Always use clean equipment.** If you use a dirty bucket or funnel to transfer the Hydraulic Fluid into the Hydraulic Fluid Reservoir, the contaminants will likely be introduced into the Fluid. When using cleaning rags, use a lint-free rag.
- **Proper storage.** Keep the Hydraulic Fluid sealed in its container until ready for use; store the Fluid in a clean, dry, and cool area.
- **Cover the Hoses and Fittings.** Before installation, do not leave the ends of the Fittings exposed; the same applies for the Hydraulic Hoses. As a general rule, keep the Hydraulic Hoses and Fittings capped and in a clean area until ready for use.
- **Filter the new Hydraulic Fluid.** Just because it is new does not necessarily mean it is *clean*. Use an offline filtration cart or kidney loop system to make sure the Hydraulic Fluid is clean before being transferred into the Hydraulic Fluid Reservoir (even using a heavy-duty nylon mesh screen is better than trusting what is left at the bottom of the barrel).
- **Avoid mixing different types of Hydraulic Fluid.** If Hydraulic Fluid needs to be replaced, make sure to flush the Hydraulic System of the old Hydraulic Fluid before you add the replacement Fluid; do not mix the two together.

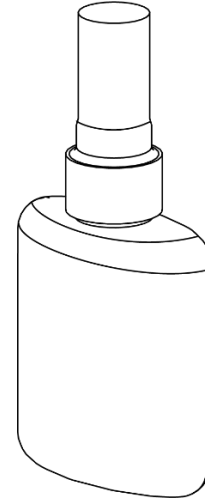
## About Thread Sealants

Liquid Thread Sealant lubricates and fills the gaps between the Fitting threads and leaves no residue that could contaminate the Hydraulic Fluid.

Other types of Thread Sealants (like Teflon Tape) can shred during installation or removal and eventually enter the Hydraulic System.

Thread Sealant can be used with most Hydraulic Fittings, although you probably only need to use with NPT connectors.

Apply the thread sealant when the ambient temperature is between +46.5°F to +70°F (+8°C to 21°C)



### To apply Thread Sealant:

1. Make sure the Fittings and connectors you are going to use are clean and dry.

If you are adding Thread Sealant to a Fitting or connector that has already been used with a different sealant, use a wire brush to thoroughly remove the old sealant before adding more.

2. Skipping the first thread, apply a small amount of Thread Sealant to the next four threads of the Fitting.

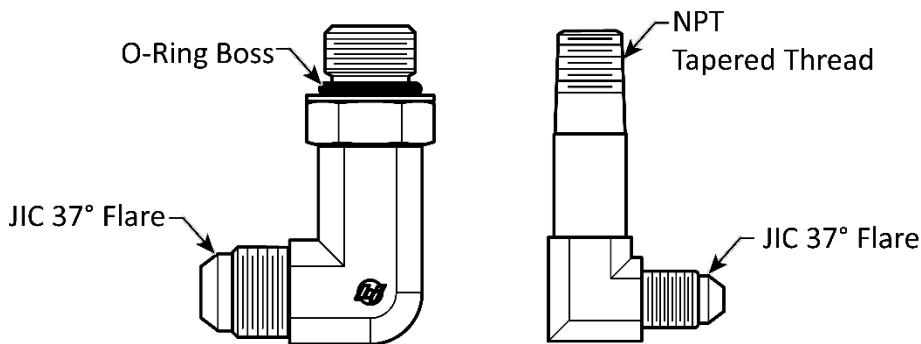
**⚠ WARNING** Always wear the proper protective equipment when handling Thread Sealant.

You only need a small amount because the sealant spreads to the other threads as it is tightened into place.

If you put too much, the excess liquid will be pushed out when the Fitting is tightened; use a rag to wipe the excess.

3. Tighten the Fitting into the connector; do **not** over tighten the Fitting.
4. Allow the **24-hour** manufacturer-recommended curing time before pressurizing the system.

## Identifying Hydraulic Fittings



Joint Industry Council (JIC)

National Pipe Thread (NPT)

## Routing the Hydraulic Hoses

It is easier to put some hydraulic components into position **before** you stand up the Posts.

All 10AP Series Lifts use either three or four Hydraulic Hoses (shown in the illustration below):

Lift Model	10AP	10AP-168	10 APX	10APX-181
Hose A	5570277		5570278	
Hose B	5570279		5570023	
Hose C	5570291	5570292	5570293	5570095
Hose D	5570174 (Wide configuration ONLY)			

All Hydraulic Hoses and Hydraulic Fitting locations are detailed in the drawing below.

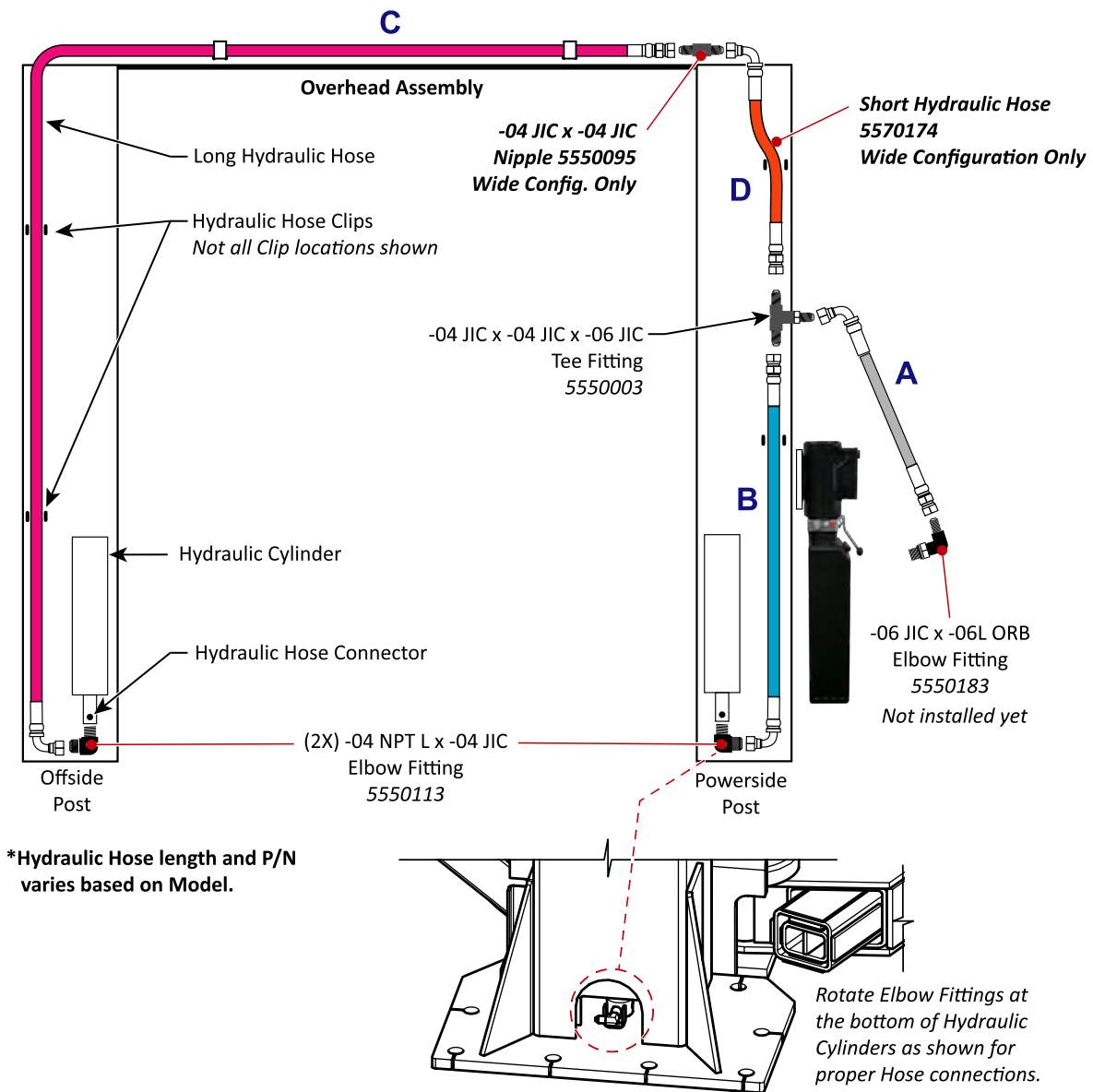


Figure for reference only – do not scale.

---

### To put the Hydraulic Hoses into position:

1. Locate the 4 Hydraulic Hoses and necessary Hydraulic Fittings: Two Elbow Fittings (5550113), one Tee Fitting (5550003), and one Nipple Fitting (5550095 – *for wide configurations only*).

**NOTICE** The Power Unit Elbow Fitting (5550183) and the Short Hydraulic Hose cannot be installed at this point, as the Power Unit is not yet in place.

2. **Starting most of the way up the Powerside Post**, push the single fitting (-06 JIC) on the Bulkhead Tee Hydraulic Fitting (5550003) through the hole above the Power Unit Mounting Bracket from inside the Powerside Post.

**NOTICE** There is only one Tee Fitting, and it is installed on the Powerside Post above where the Power Unit will be installed.

3. Tighten the Nut on the **outside** of the Powerside Post to hold the Bulkhead Tee Fitting in place.
4. **Switching to the bottom of the Powerside Post**, remove the Shipping Plug from the Hydraulic Hose Connector on the bottom of the Hydraulic Cylinder.

**Important** Keep a rag nearby in case some fluid leaks out of the Hydraulic Hose Connector when you remove the Shipping Plug.

5. Connect one of the two Elbow Fittings (5550113) to the Hydraulic Hose Connector; tighten the Elbow Fitting appropriately.

Point the JIC end of the Fitting towards the side of the Post with the Clips. **Use liquid thread sealant on the NPT male threads only.**

6. Turn the Hydraulic Cylinder so that the Elbow Hydraulic Fitting is accessible from the bottom back side of the Powerside Post.

**NOTICE** When routing Hydraulic Hoses, after they are positioned correctly, put them into the nearby Clips and lightly crimp the Clips together along the side of each Post. When all Hydraulic Hoses have been installed, go back and fully crimp all the Clips.

7. Take the Medium Hydraulic Hose, connect the Straight End to the bottom of the Tee Fitting (5550003), and tighten securely.
8. Push the Curved End of the Medium Hydraulic Hose down to the bottom of the Powerside Post and connect it to the JIC end of the Elbow Hydraulic Fitting (5550113); tighten securely.
9. **Switching to the Offside Post**, connect the other Elbow Fitting (5550113) to the Hydraulic Hose Port at the bottom of the Hydraulic Cylinder.
10. Tighten the Elbow Fitting securely; make sure to leave the unconnected end of the fitting pointing towards the side with the Clips.
11. Take the Long Hydraulic Hose, push the Curved End down through the Post, then connect the Curved End to the Elbow Fitting (5550113) you just connected and tighten securely.

Make sure to clip the Long Hydraulic Hose to the Clips in the Post.

12. Carefully coil up and bind the rest of the Long Hydraulic Hose, then leave it resting on top of the Offside Post until later in the installation.

You should now have the Long Hydraulic Hose connected to the bottom of the Hydraulic Cylinder in the Offside Post, with the rest of the Long Hydraulic Hose coiled up at the top of the Offside Post. It will be connected to the rest of the Hydraulic System **later in the installation.**

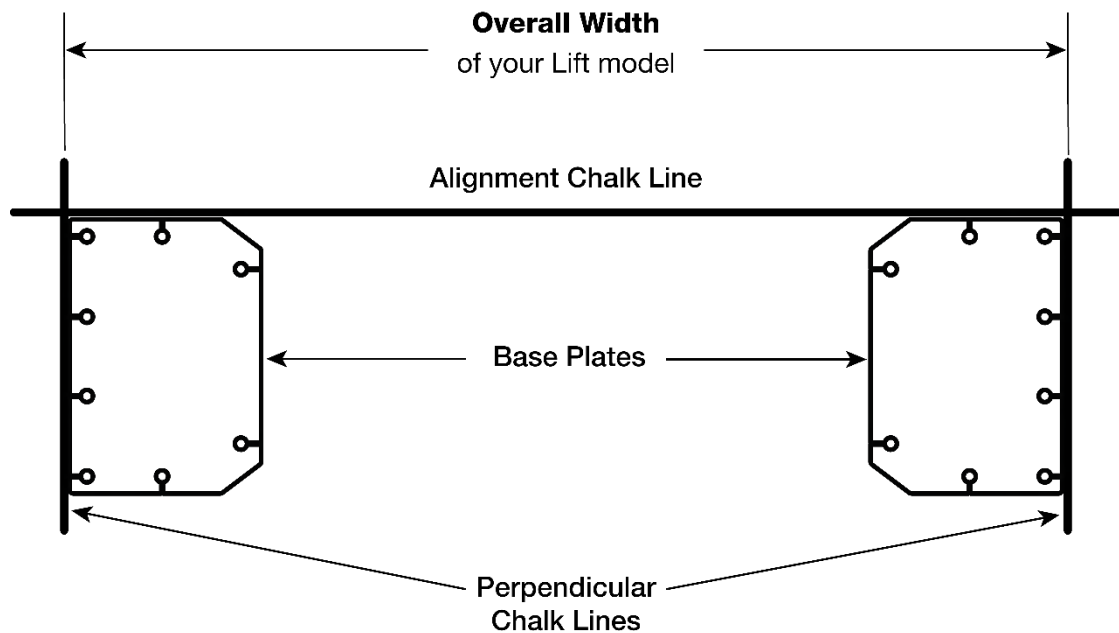
---

## Creating Chalk Line Guides

Based on the Specifications for your Lift, create Chalk Line Guides on the ground for the two Posts prior to moving them into position.

Use the **Overall Width** value in **Specifications** for your Lift model to determine where to place the Chalk Line Guides. The Overall Width value is defined as the distance from the back of one base plate to the back of the other base plate. The Overall Width setting may be set to Narrow (135 in. / 3,431 mm) or Wide (145 in. / 3,683 mm), depending on the selection for your Lift model.

The following illustration shows how to create Chalk Line Guides for a 10AP Series Lift.



*Top View of the Base Plates. Not all components are shown.*

Make sure to choose the Width Overall value for the Narrow or Wide orientation, based on the selection you made earlier.

### To add Chalk Line Guides:

1. Decide where you want to locate the Lift. Verify the clearances around the Lift area.
2. Create an Alignment Chalk Line at the Front of the Lift.

Make the Alignment Chalk Line longer than the **Overall Width** setting for your Lift model.

Make sure to use the **Overall Width** setting for Narrow or Wide orientation.

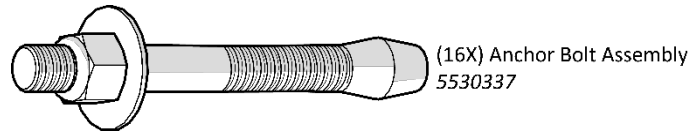
3. Create two Perpendicular Chalk Lines at 90° angles to the Alignment Chalk Lines at the **Overall Width** distance for the Lift model you are installing.

The two Perpendicular Chalk Lines must be a specified distance from each other, the Overall Width setting **Narrow (135 in. / 3,431 mm)** or **Wide (145 in. / 3,683 mm)**, depending on the selection for your Lift model.

4. When you move the Posts into position, put the Base Plates into the corners created by the Chalk Line Guides, as shown in the figure above.

---

## Anchoring the Posts



**⚠ DANGER** *Pay special attention when installing the Posts. If done incorrectly, the Lift could fall over, potentially causing damage to the Vehicle, the Lift, and injuring bystanders. BendPak strongly recommends consulting a Concrete Specialist early in your planning process for Lift installations. A Concrete Specialist will make adjustments to account for national, state, and local building codes as well as local weather conditions, soil composition, base preparation, load bearing, seismic requirements and any other structural concerns that may arise.*

Concrete specifications are:

- **Depth:** 4.25 inches / 108 mm thick, minimum, steel reinforced.
- **PSI:** 3,000 PSI, minimum
- **Cured:** 28 days, minimum

Anchor Bolt specifications are:

- **Length:** 6.3 inches / 160 mm
- **Diameter:** .75 inch / 19 mm
- **Anchor torque:** 85 – 95 ft. lb.
- **Effective embedment:** 3.25 inches / 82.5 mm or more

The Concrete floor where you want to install your Lift must meet the following requirements:

- The floor must be a flat, level concrete floor. **Do not install the Lift on a surface with more than three degrees of slope.**
- Do not install the Lift on cracked or defective Concrete.
- Check the floor for the possibility of it being a post-tension slab. In this case, contact the building architect before drilling. Contact a qualified professional to locate the tensioned cables before drilling.

**⚠ WARNING** Cutting through a tensioned cable can result in injury or death. Do not drill into a post-tension slab unless the building architect confirms you are **not** going to hit a tensioned cable, or you have located it using ground penetrating radar. **If colored sheath comes up during drilling, stop drilling immediately.**

**⚠ WARNING** Your concrete and Anchor Bolts **must** meet these specifications. Only install your Lift on a Concrete surface. If you install a Lift on asphalt or any other surface, or your Concrete or Anchor Bolts do not meet these specifications, it could lead to product damage, Vehicle damage, personal injury, or even loss of life.

BendPak Lifts are supplied with installation instructions and concrete fasteners meeting the criteria as prescribed by the latest version of the American National Standard “Automotive Lifts – Safety Requirements for Construction, Testing, and Validation”.

**⚠ WARNING** Use **only** the ALI-certified Anchor Bolts that came with your 10AP Series Two-Post Lift. If you use components from a different source, you void your warranty and compromise the safety of everyone who installs or uses the Lift.

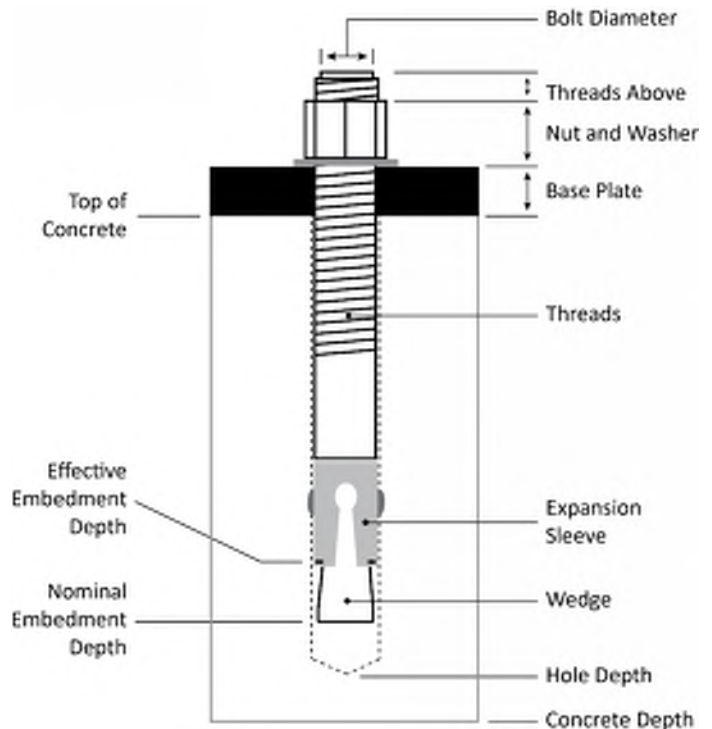


Lift buyers are responsible for conforming to all regional, structural, and seismic anchoring requirements specified by any other agencies and/or codes, such as the Uniform Building Code and/or International Building Code.

**NOTICE** Consider **not** torquing the Anchor Bolts into position yet. Installing the Overhead Assembly and doing final leveling may be easier if there is some play in the Posts.

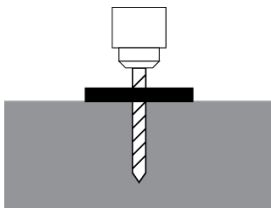
**Effective Embedment** is the location in the Hole where the Expansion Sleeve presses into the Concrete. This is where the Anchor Bolts get their holding strength, the further down into the Hole, the greater the holding strength.

**Nominal Embedment** is how far down into the Hole the bottom of the Anchor Bolt is, which does not tell you anything about the holding strength.



**To install the Posts:**

1. Using a Forklift or Shop Crane, move the Posts to the Chalk Line Guides you created earlier.
2. Carefully stand up each Post, *one at a time*, and move them to the appropriate location.
3. Double check your measurements against the **Specifications** for your Lift model.
4. Using the Base Plates as guides, drill each hole **4 inches** deep using a carbide bit.



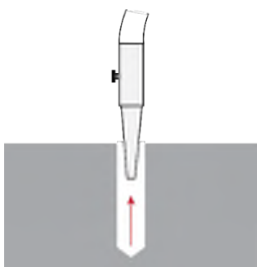
Go in straight; do not let the drill wobble.

The diameter of the drill bit must be the same as the diameter of the Anchor Bolt. If you are using a 3/4 inch diameter Anchor Bolt, for example, use a 3/4 inch diameter drill bit.

**Do not drill all the way through the Concrete;** if you punch completely through the slab, you could compromise the holding strength of the Anchor Bolts.

5. Vacuum each hole clean.

**WARNING** You **must** use the appropriate safety gear including safety glasses, dust masks, gloves, steel-toed work boots and heavy work clothes when anchoring the Posts.



BendPak recommends using a vacuum to get the hole very clean.

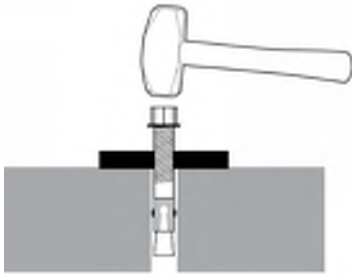
You can also use a wire brush, hand pump, or compressed air; just **make sure to thoroughly clean each hole.**

Do **not** ream the hole. Do **not** make the hole any wider than the drill bit made it.

## NOTICE

The holding strength of an Anchor Bolt is partially based on the how cleanly the Expansion Sleeve presses against the Concrete. If the hole is dirty or too wide, there is less holding strength.

6. Make sure the Washer and Nut are in place, then insert the Anchor Bolt into the hole.

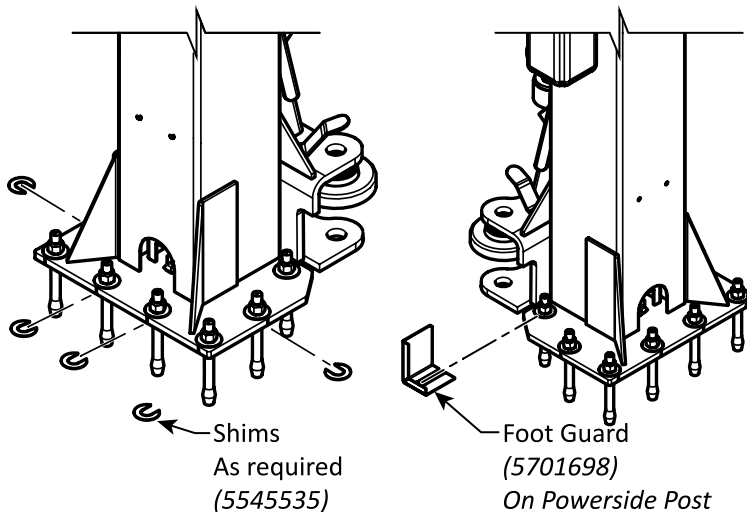


The Expansion Sleeve of the Anchor Bolt may prevent the Anchor Bolt from passing through the hole in the Base Plate; this is normal. Use a hammer or mallet to get the Expansion Sleeve through the Base Plate and into the hole.

Even using a hammer or mallet, the Anchor Bolt should only go into the hole part of the way; this is normal. If the Anchor Bolt goes all the way in with little or no resistance, the hole is too wide.

Once past the hole in the Base Plate, the Anchor Bolt eventually stops going down into the hole as the Expansion Sleeve contacts the sides of the hole; this is normal.

7. Hammer or mallet the Anchor Bolt the rest of the way down into the hole, and then stop when the Washer is snug against the Base Plate.
8. Plumb each Post; install Shims as required. See **Troubleshooting Lift Arm Lock Disengagement** if you are required to shim  $\geq .5$  in / 13 mm.



*Do not scale.*



### Tip

If you are going to torque the Anchor Bolts later, so that installing the Overhead Assembly and final leveling is a little easier, skip the next step. Make sure the Anchor Bolts are securely in position; This will ensure that the Posts will not move too much during the rest of the installation.

9. Tighten each Nut **clockwise** to the recommended installation torque, 85 – 95 pound feet, using a Torque Wrench.



### CAUTION

Do **not** use an impact wrench to torque the Anchor Bolts.

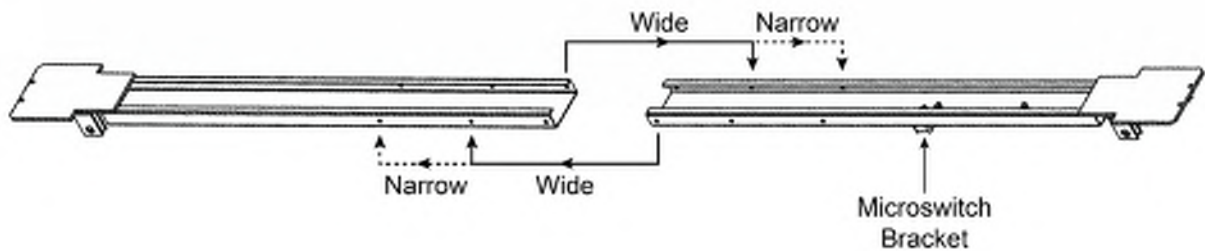
10. Install the Foot Guard on the Powerside Post as shown on the previous page.

## Installing the Overhead Assembly and Safety Shutoff Bar

The Overhead Assembly is installed above and between the Powerside and Offside Posts. It holds the Equalizing Cables, the Hydraulic Hoses, the Microswitch wiring, and the Safety Lock Cable.

The Overhead Assembly is two pieces that are bolted together. The Overhead Assembly and the Safety Shutoff Bar come from the factory already assembled in the Narrow Configuration.

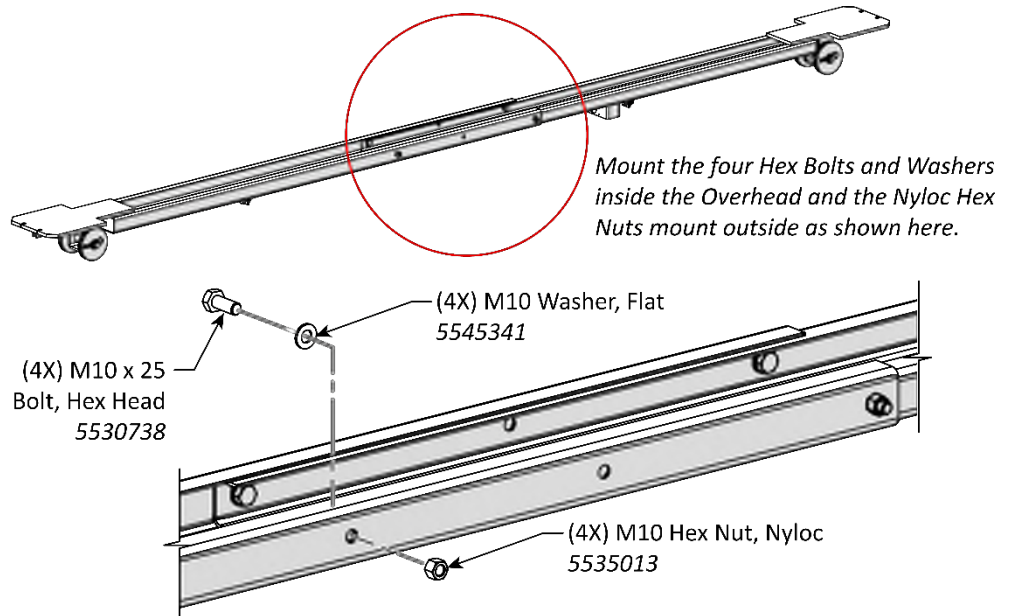
**NOTICE** BendPak recommends placing the Overhead Assembly on sawhorses to prepare it. The following graphic shows the bolting locations for both Narrow and Wide Configurations.



**Note:** When you line up the two Overhead Assembly pieces together, there will be four holes that go through both pieces. Two holes on each side of the Overhead Assembly.

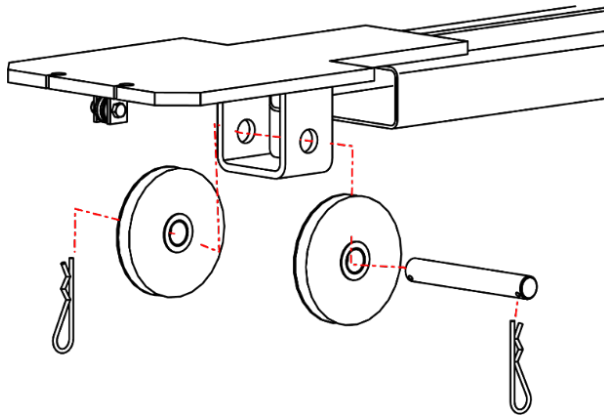
### To prepare and install the Overhead Assembly:

1. If the Overhead Assembly is delivered unassembled, locate the two Overhead Assembly pieces and the four Hex-Head Bolts, Flat Washers, and four Nyloc Nuts required to connect them.
2. Secure the Overhead Assembly together in the desired width using the hardware listed in the illustration.



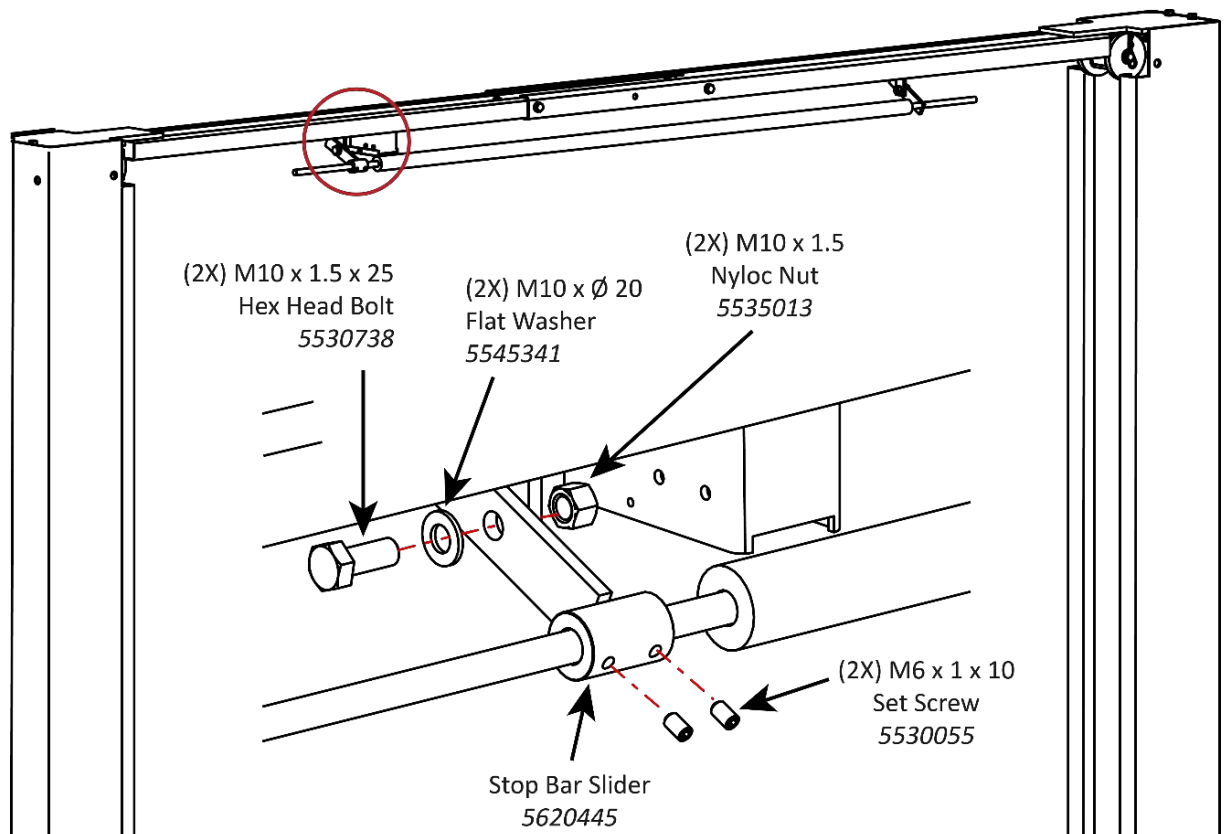
**Important:** Mount the M10 Hex Bolt Heads and Flat Washers inside the Overhead, Nyloc Nuts outside.

- Remove all four Overhead Assembly Sheaves, their Pins and Cotter Pins from the ends of the Overhead Assembly pieces. Keep the Sheave components nearby, you will be reinstalling them in the same order in the next section.



- Attach one end of the Safety Shutoff Bar to the Overhead Assembly, as shown below; use the same type of M10 hardware to secure the other end of the Shutoff Bar.

If you are switching the Safety Shutoff Bar from Narrow to Wide Configuration, loosen the Slider Set Screws, adjust the Safety Shutoff Bar appropriately, and then re-tighten the Slider Set Screws.

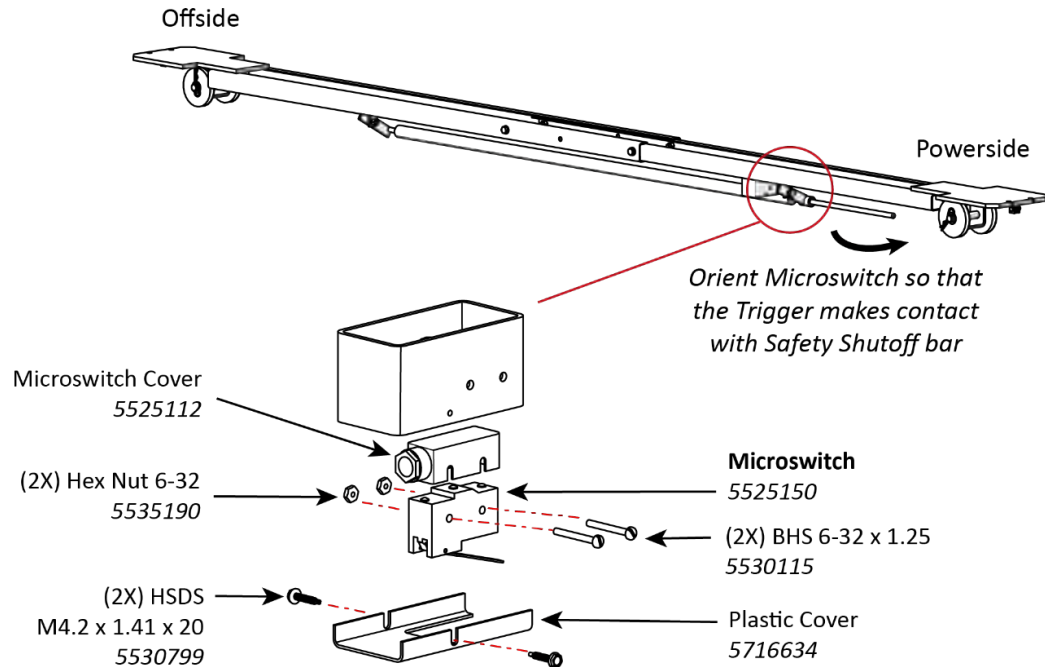


*Reference only – do not scale.*

## Installing the Microswitch

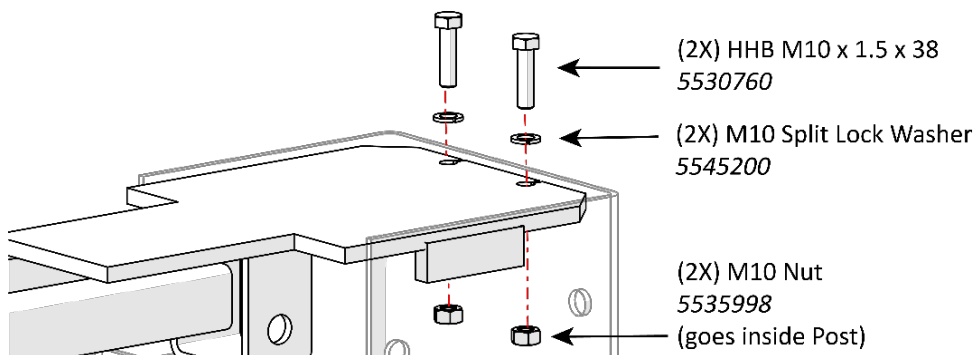
The following procedure describes how to install a Microswitch on the Overhead Assembly but does not describe how to wire it; wiring is covered later in the installation. The Microswitch **wiring** goes over the Overhead Assembly and down the Powerside Post to the Power Unit.

If you have **two** Microswitches because you are using a three-phase Power Unit, simply install the two of them next to each other in the Microswitch Bracket.



### To install the Microswitch:

1. Locate the Microswitch, the Microswitch Cover, and hardware required to install the Microswitch.
2. Put the Microswitch into position in the Microswitch Bracket such that the Safety Shutoff Bar, when moved upwards, will push up the Trigger.
3. If you are installing a second Microswitch, put it into position next to the one you just installed.
4. Use the supplied hardware to secure the Microswitch and Microswitch Cover in place.
5. Use an appropriate lifting device to put the Overhead Assembly into position, making sure to position the Microswitch Bracket on the same side as the Powerside Post.
6. Bolt the Overhead Assembly to the top of the Posts using two Bolts on each end.



*Do not scale.*

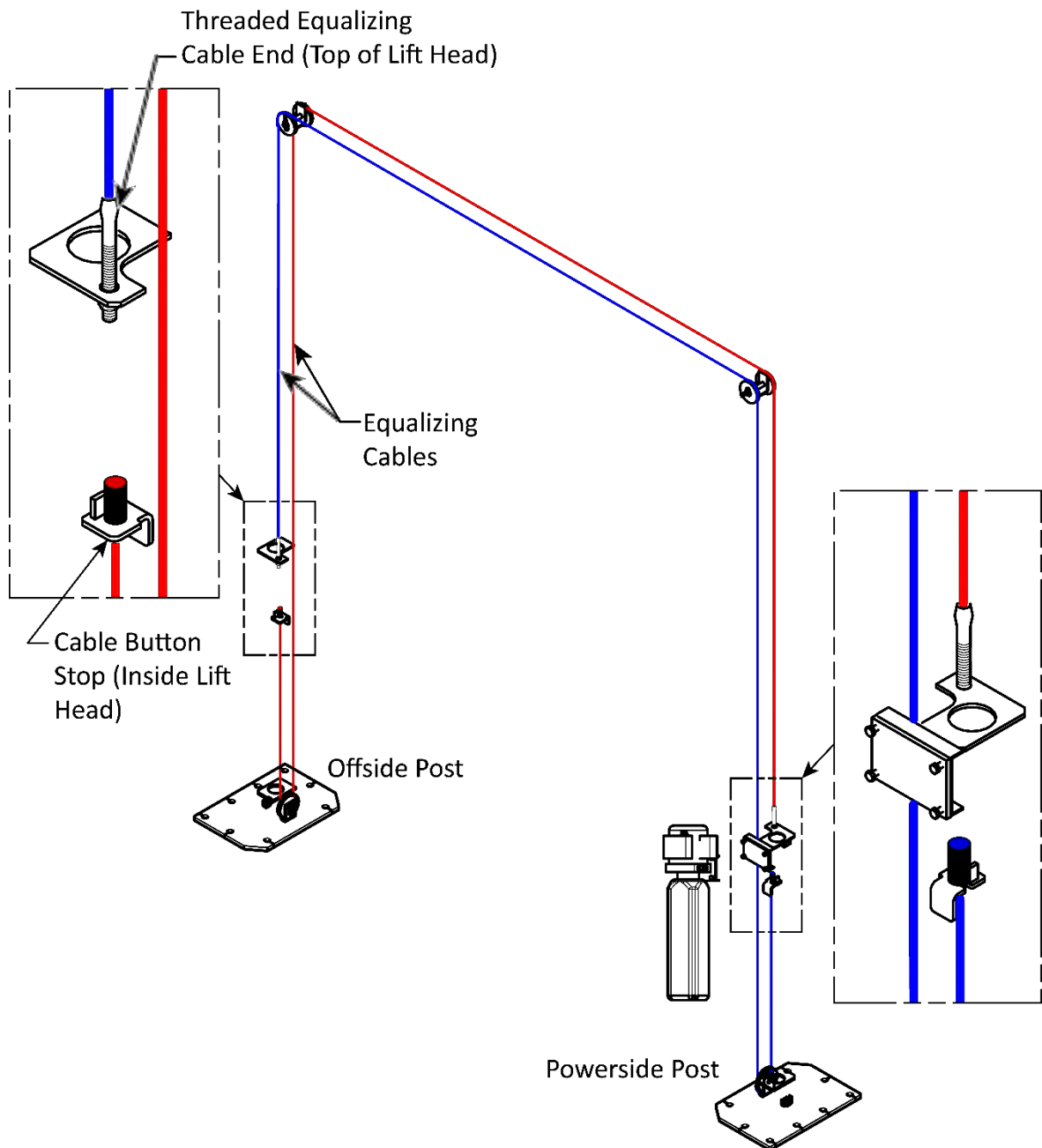
## Completing the Equalizing Cables Installation

Both Equalizing Cables should have been put into position coiled at the top of the Lift Posts before the Posts were raised, which was covered in [Putting the Equalizing Cables into Position](#).

This section picks up where that section left off: the Button Ends of the Equalizing Cables (on both Posts) have been installed, routed around the Post Sheaves, and then pushed up above the Lift Head. They now need to be routed over the Overhead Assembly and then down to the top of the Lift Head.

**NOTICE** If your Equalizing Cables are not yet in position, you must go back and put them into position before performing the following procedure.

When Equalizing Cables are fully routed, they are mirror images of each other. Refer to the figure below.



*Not to scale. Components removed for clarity.*

## To route the Equalizing Cables:

1. Using a Forklift or Shop Crane, manually raise both Lift Heads about 28 inches / 711 mm off the ground and engage them on the closest Safety Lock.

**Measure to verify both Lift Heads are the same distance off the ground.**

**⚠ WARNING** You must use a proper lifting device such as a Forklift or Shop Crane to raise and position the Lift components.

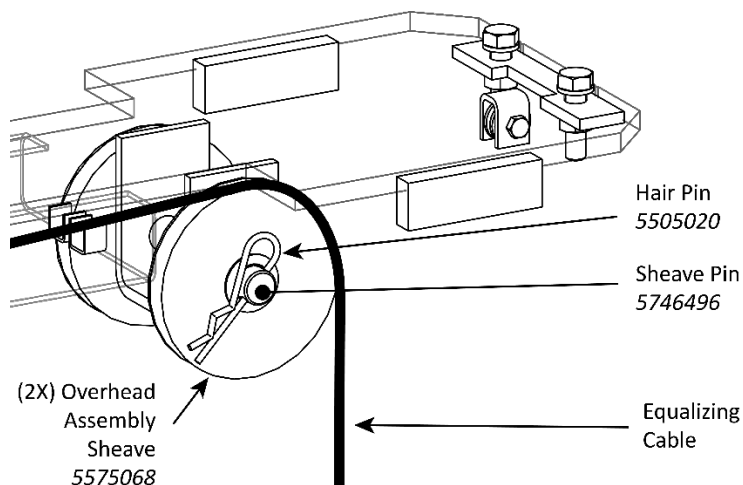
2. Make sure the Button Ends of both Equalizing Cables are still in the Slots in their Cable Button Stops, that both Equalizing Cables go under the Post Sheave in their Posts, and that the Threaded Ends have been routed through the Hole at the Top of the Lift Head.

If either cable is not correct, fix it; you cannot continue until the Equalizing Cables are in their correct starting positions. Remember, for a Wide Configuration, use the Button End at the very end of the Equalizing Cable. For a Narrow Configuration, use the Button End away from the end of the Equalizing Cable.

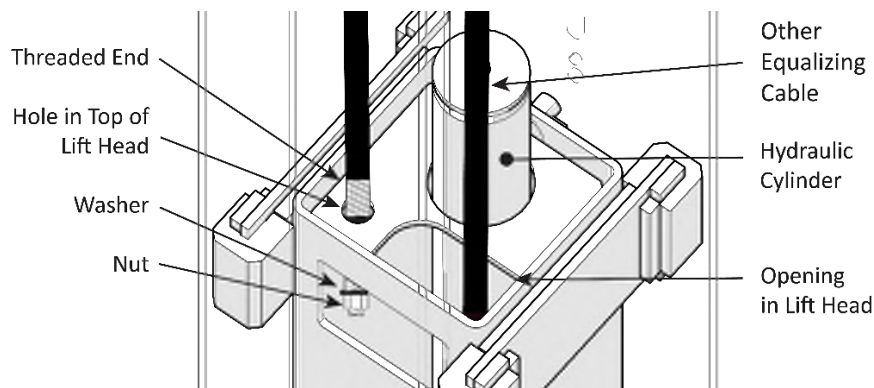
3. Choose which one of the two Equalizing Cables you are going to put into position first, then remove the Nut from the Threaded End of that Cable.

**NOTICE** The Overhead Assembly Sheave, Sheave Pin, and Hair Pin were previously removed. If they were mistakenly re-installed, you need to remove them again.

4. Route the Threaded End of the Equalizing Cable up on the inside of the Post, over the Overhead Sheave Assembly, and then out over the top of the Overhead Assembly.



5. Lubricate the Sheave Pin and Bearing with Red Lithium Grease, then re-install the Overhead Assembly Sheave, Sheave Pin, and Hair Pin.
6. At the other Post, remove the Nut from the Threaded End of the other Equalizing Cable.
7. Route the Threaded End over the top of the Overhead Assembly Sheave, and then down the Post towards the Lift Head.
8. Lubricate the Sheave Pin and Bearing with Red Lithium Grease, then re-install the Overhead Assembly Sheave, Sheave Pin, and Hair Pin.
9. Put the Threaded End of the Equalizing Cable through the hole at the top of the Lift Head, then install the Nut and securely tighten.



*Reference only – do not scale.*

10. Perform Steps 3 through 9 for the other Equalizing Cable.

## Mounting the Power Unit

This section describes how to mount the Power Unit to the Powerside Post. You do **not** need an Electrician to **mount** the Power Unit, but you do need an Electrician to **connect** the Power Unit. Refer to **Connecting the Power Unit** for installation information for your Electrician and specific information about the Power Unit that came with your Lift.

**NOTICE** Do not connect the Power Unit to the Hydraulic System or to the power source at this point in the installation; those connections will be made later.

**CAUTION** The Power Unit is heavy. BendPak recommends having one person hold the Power Unit while a second person bolts it into place.

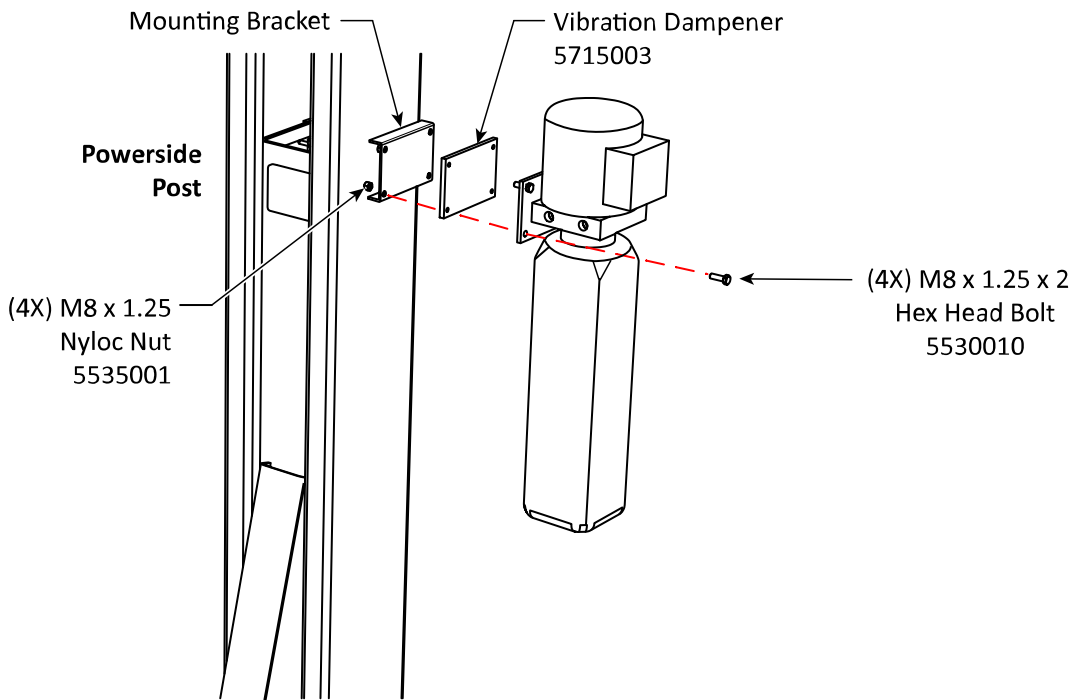
### To mount the Power Unit:

1. Find the supplied four Hex Head Bolts, four Nyloc Nuts, and one Vibration Dampener.
2. Remove the Power Unit from the packaging material.

**Important** The Power Unit is heavy. BendPak recommends having one person hold the Power Unit while a second person bolts it into place.

3. Put the Vibration Dampener into place next to the Mounting Bracket on the Powerside Post.
4. Move the Power Unit Mount Plate next to the Vibration Dampener.
5. Secure the Power Unit and Vibration Dampener using the hardware listed below, using all four holes to secure the Power Unit.



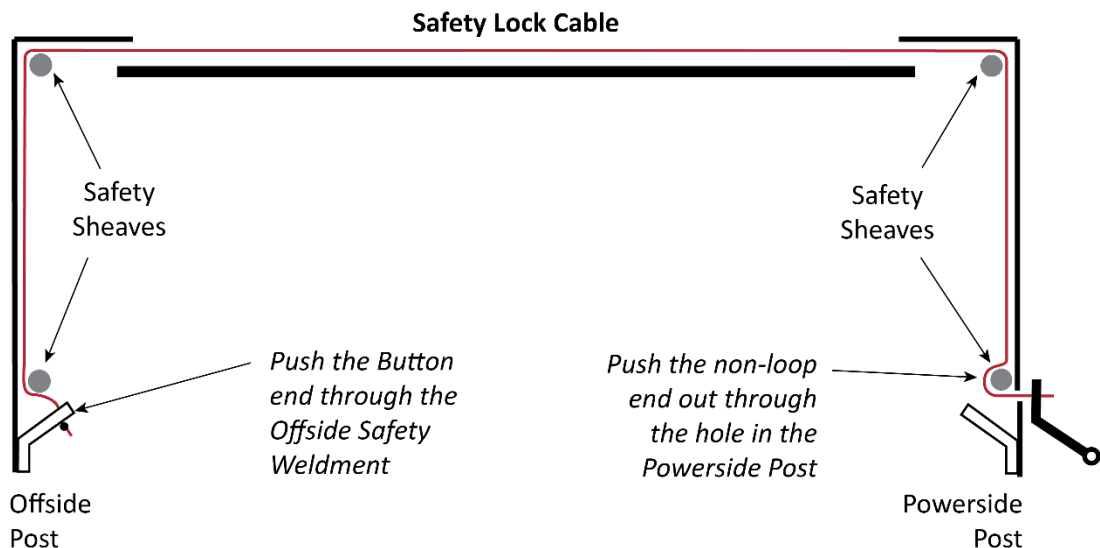


## Installing the Safety Lock Cable

The Safety Lock Cable and the Safety Lock Release Handle are used to release the Safety Locks, allowing the Lift to be lowered.

The Safety Lock Cable should have been installed and left in place in the [Installing the Safety Assemblies](#) section,

The following drawing shows the path the Safety Lock Cable travels from Safety Assembly on the Offside Post to the Safety Assembly on the Powerside Post.

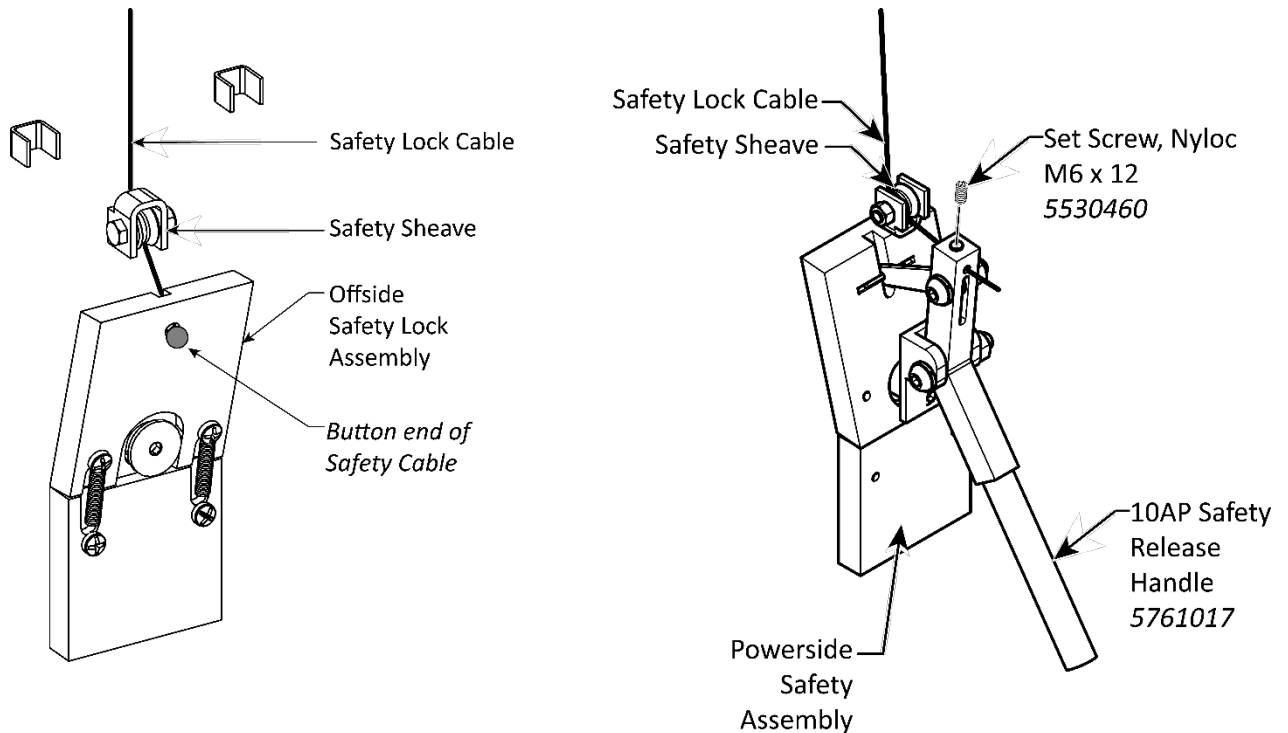


*Not drawn to scale. Some components exaggerated or not shown for clarity.*

The following illustration shows the Safety Lock Cable connections to the Safety Assemblies.

**Offside Safety:**

**Powerside Safety:**

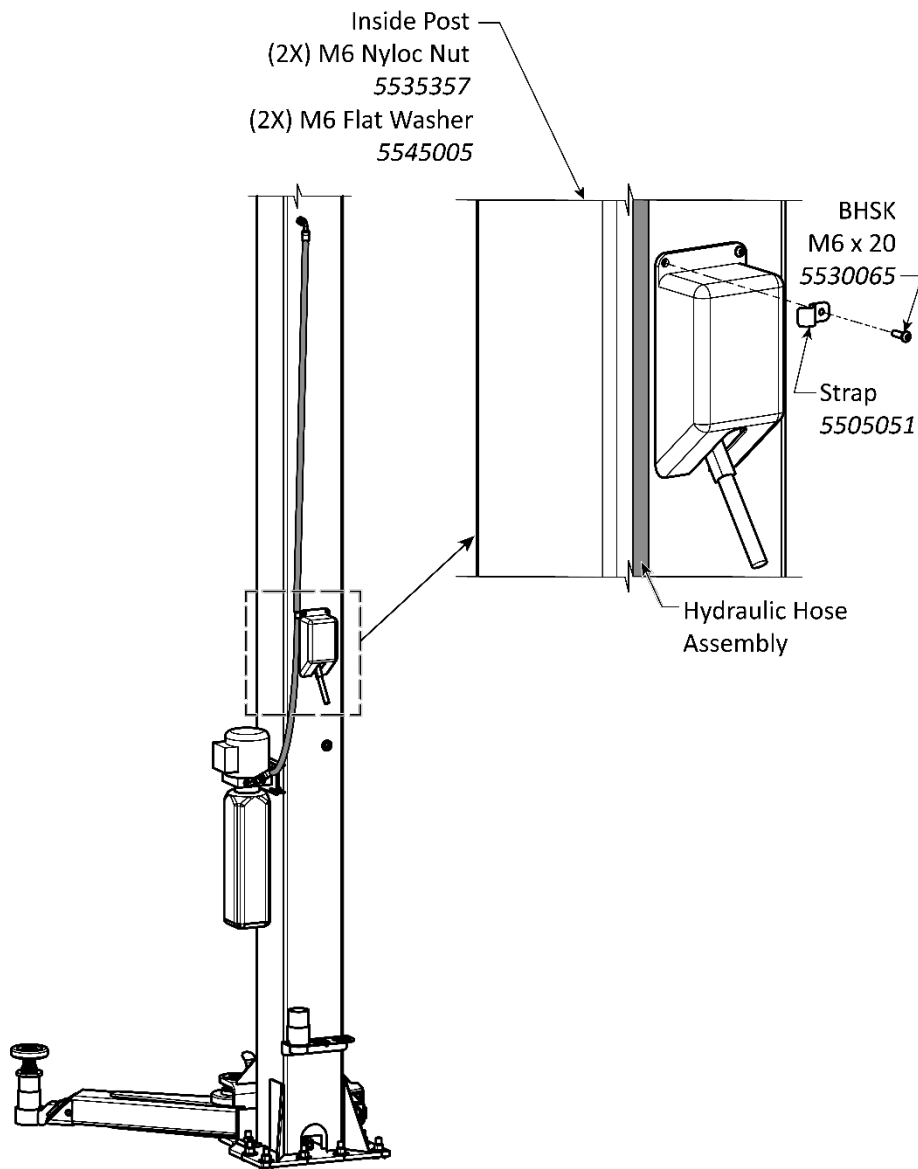


*Reference only – do not scale.*

**⚠ WARNING** You will need to access the Overhead Assembly to route the Safety Lock Cable. Use care to avoid falling when working on a ladder or other lifting device.

### **To route and connect the Safety Lock Cable:**

1. Locate the Safety Lock Cable. This should be coiled at the top of the Offside Post.
2. Route the non-button end under the Safety Sheave, upwards on the inside of the Offside Post, up and over the Safety Sheave at the top of the Offside Post, across the Overhead Assembly, over the Safety Sheave at the top of the Powerside Post, and then downwards, on the inside of the Powerside Post, towards the Powerside Safety Assembly.
3. **Switching to the Powerside Post**, route the non-button end of the Safety Lock Cable through the Safety Sheave.
4. Temporarily remove the M6 Hex Head Bolt (5530031) and M6 Split Lock Washer (5545026) that is loosely secured to the Safety Lock Release Handle.
5. Route the Safety Lock Cable through the hole in the Safety Release Handle, then replace the Bolt and Split-Lock Washer. Tightly secure the connection.
6. Install the Safety Cover (5716072) to the Powerside Post; there is no Safety Cover for the Offside Post. Make sure the Safety Lock Release is usable through the slot on the front.



*Figure not to scale. Shown with optional equipment.*

**⚠ CAUTION** Verify the Safety Lock Cable stays on its Safety Sheaves; this keeps it out of the way of the Equalizing Cables and the Hydraulic Hoses.

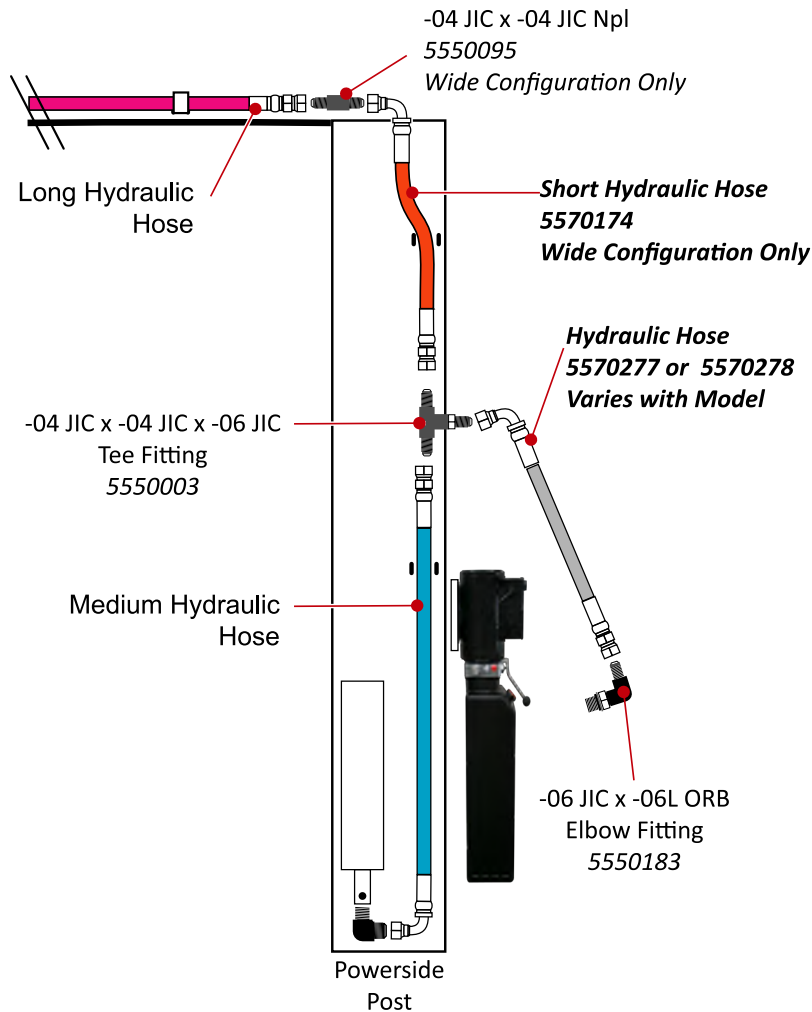
**⚠ DANGER** Verify both the Powerside and the Offside Safety Assemblies engage properly **before** operating the Lift.

## Connecting the Hydraulic Hoses

Some of the Hydraulic Hoses were put into place much earlier in the installation. It is now time to finish installing the Hydraulic Hoses and connect them to the Power Unit.

If they were **not** put into position earlier, you must do so now, **before** beginning the following procedure. Refer to **Routing the Hydraulic Hoses** for full instructions.

The following illustration shows how to connect the Hydraulic Hoses in both Lift configurations.



*Drawing shows side of Powerside Post. Not drawn to scale. Not all components shown.*

### To finish connecting the Hydraulic Hoses:

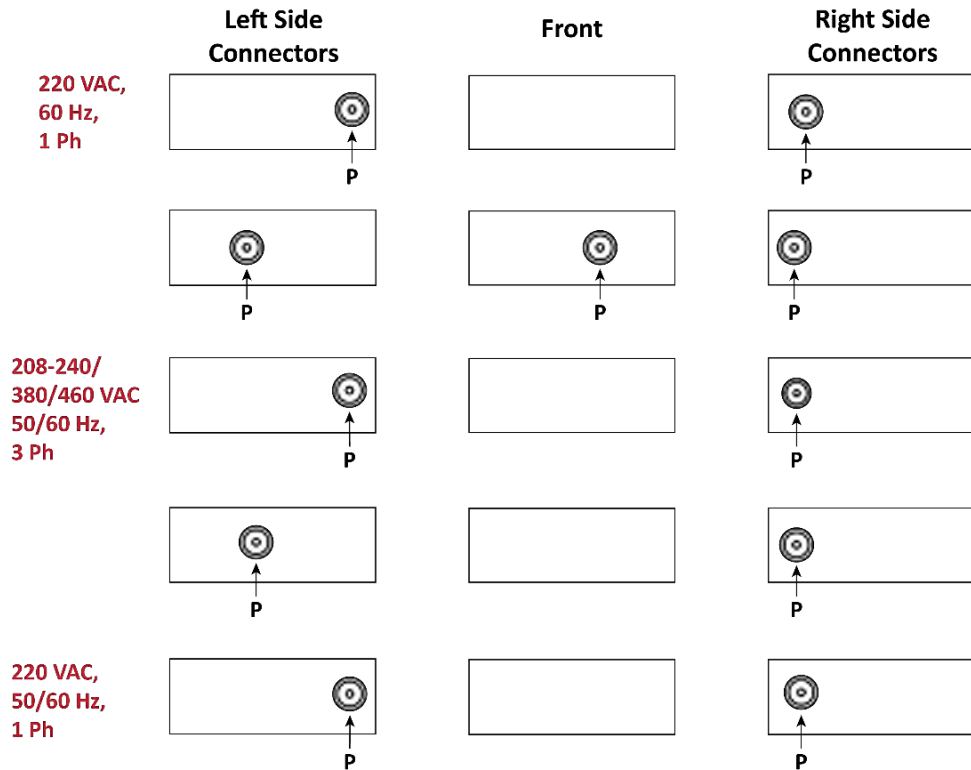
1. Locate the  $\text{\O}10\text{mm}$  Short Hydraulic Hose and the remaining Elbow ORB Hydraulic Fitting (5550183).
2. **On the Power Unit**, locate a Hydraulic Pressure Port on the Power Unit (labeled P, P1, or P2), remove the shipping plug, and then install the Elbow Hydraulic Fitting. Place a few drops of hydraulic fluid on the O-ring before installing on the Power Unit.

See the drawing on the following page for possible Hydraulic Pressure Port locations.

**Note:** There are multiple Ports on the Power Units that are used with 10AP Series Lifts. However, each 10AP Series Lift uses only one Hydraulic Pressure Port (labeled **P** in the drawing)

below). Do **not** connect to any of the other Ports and do **not** connect to more than one Hydraulic Pressure Port.

The following drawing shows the possible Hydraulic Pressure Port locations, depending on the Power Unit you have.



3. Tighten the Elbow Fitting appropriately; make sure to leave the 06 JIC connector facing up, towards the Tee Fitting.
4. Connect the Curved End of the Short Hydraulic Hose to the Tee Fitting; finger tighten the connection.

This connection is made on the outside of the Powerside Post. If the 06 JIC connector of the Tee Fitting is **not** on the outside of the Powerside Post, this means the Tee Fitting was not installed correctly. Return to [Routing the Hydraulic Hoses](#) for more information.

5. Connect the Straight End of the Short Hydraulic Hose on the Elbow Fitting; finger tighten the connection.
6. **Switching to the Offside Post**, take the Long Hydraulic Hose and route it over the Overhead Assembly towards the Powerside Post, making sure to put the hose through the Clips in the Post.
7. If you are installing the Lift in a **Wide** Configuration, you need to install the Short Hydraulic Hose to the top of the Tee Hydraulic Fitting, and then install a Nipple Hydraulic Fitting (5550095) to the top of the Short Hydraulic Hose.

The Short Hydraulic Hose is **not used for Narrow Configurations**.

8. Connect the Straight End of either the Long Hydraulic Hose (for Narrow Configurations) or the Very Short Hydraulic Line (for Wide Configurations) to the 04 JIC connector facing up on the Tee Hydraulic Fitting; finger tighten the connection.
9. Using appropriate tools, go back and securely tighten all the finger-tightened connections.

## Installing the Lift Arms

Lift Arms are what raise Vehicles off the ground. Your Lift comes with four Lift Arms. Lift Arms come uninstalled.

Install the Arms as detailed in the figure below.

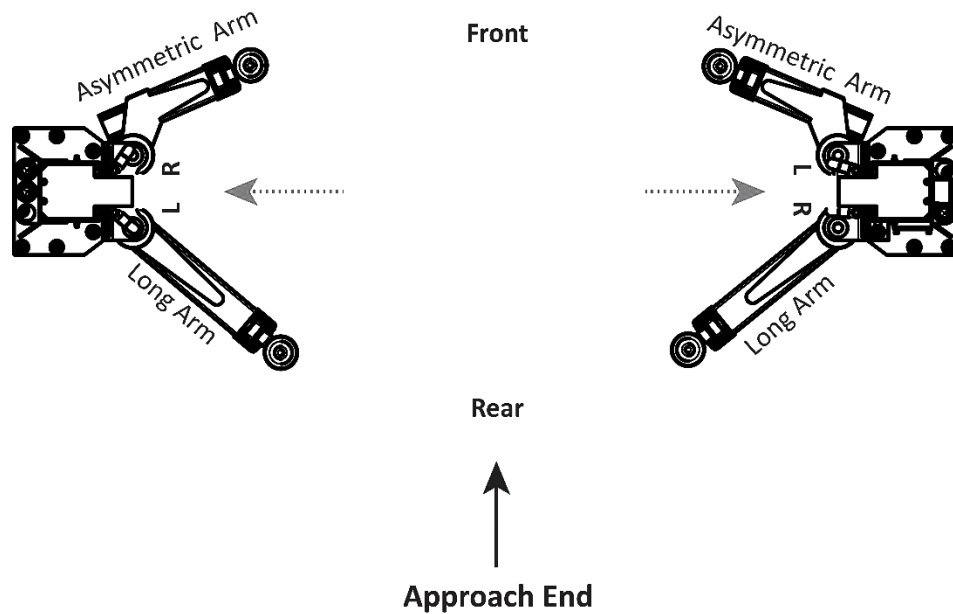
The **first task** is to determine the Front and Rear of the Lift:

- **If you can only drive in one way.** The approach side is the Rear, the other side is the Front.
- **If you can drive in either way.** Choose one side as the Front and the other side as the Rear. The best way to make this decision is to pick one approach direction for the Vehicles you will be putting on the Lift, even though you can drive in either way. Also consider the ease of backing out of from your chosen approach. Once the decision is made, you approach the Lift from the Rear, so the other side is the Front.

The **second task** is whether the Lift Arm is a 'right' or a 'left'. This is determined separately per Post.

To determine right and left, stand between the two Posts, then turn to face one of them straight on. From this viewpoint, the right side of the Post is the 'right' and the left side of the Post is the 'left'.

After finishing the first Post, repeat the process for the second Post.



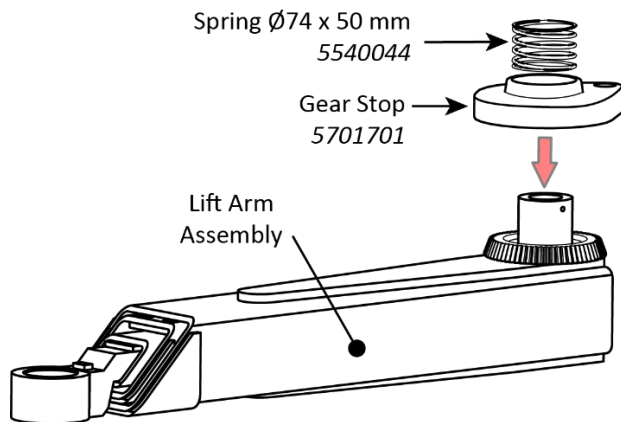
*Reference only – do not scale.*

### To install a Lift Arm in a Lift Head:

1. Using a Forklift or Shop Crane, raise the desired Lift Head to the first locking position; you need that room to work.

**⚠ CAUTION** The Lift Head and Lift Arms are heavy. Exercise caution when raising the Lift Head to the first locking position using a Forklift or Shop Crane.

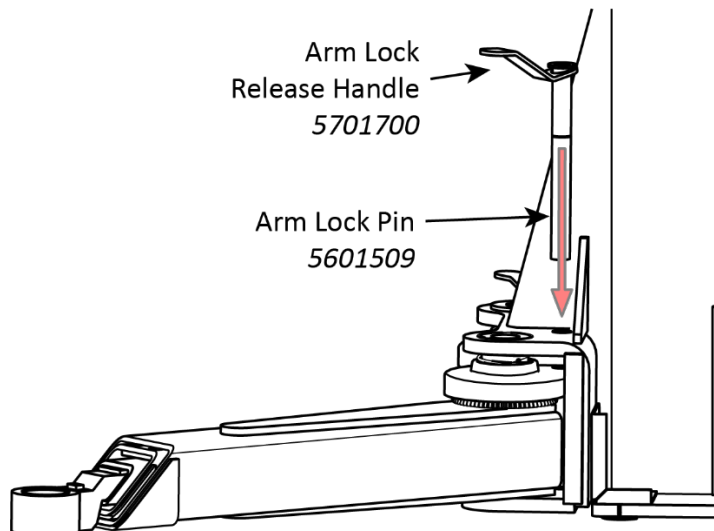
2. Place a Gear Stop and Spring on the Lift Arm Assembly.



*Reference only – do not scale.*

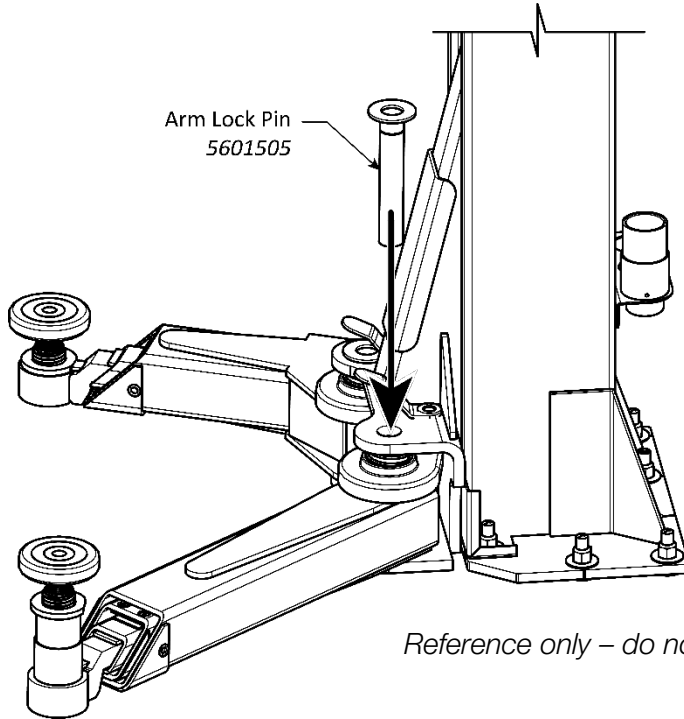
3. Move the appropriate Lift Arm into place in the Lift Head, then Slide the Arm Lock Pin and Arm Lock Release Handle through the holes in the Lift Head and Lift Arm Assembly.

The holes at the end of the Lift Arm need to be inside the Lift Head and lined up with the holes in the Lift Head.



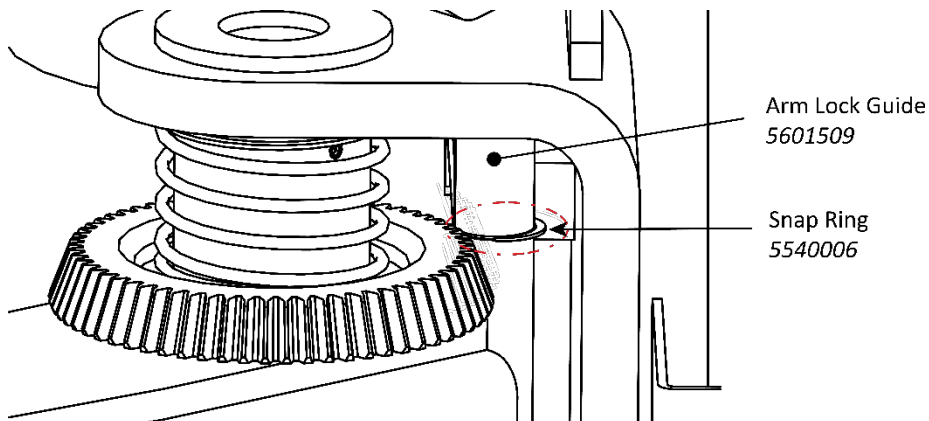
*Reference only – do not scale.*

- Slide the Arm Lock Pin through the holes in the Lift Head and the Lift Arm Assembly.

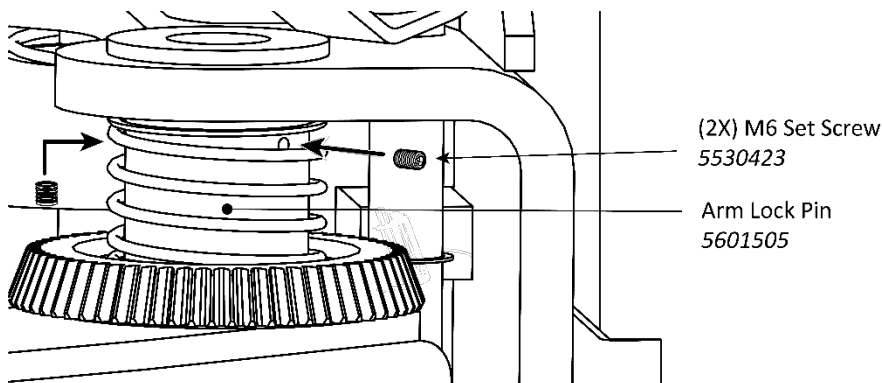


*Reference only – do not scale. Shown with optional equipment*

- Push a Snap Ring into its grooves on the bottom of the Arm Lock Guide Rod.



- Secure a Set Screw on either side of the Lift Head Pin; two Set Screws per each Lift Head Pin.



- Repeat Steps 1 – 6 for the other three Lift Arm Assemblies.



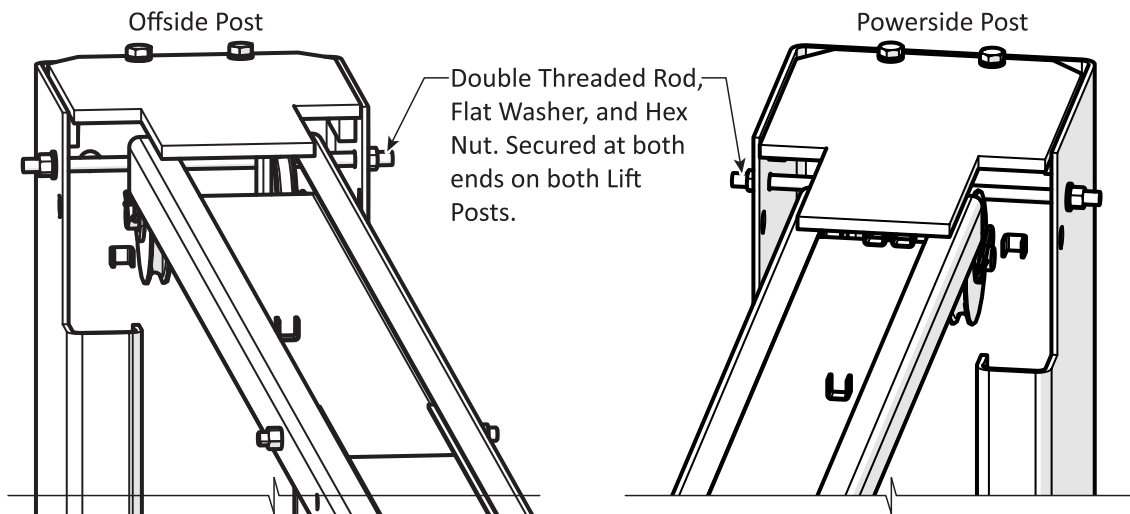
**⚠ WARNING** Make sure that the Arm Restraint Gears and the Gear Stops are meshing and staying in place when up to 150 pounds of lateral force is applied before putting the Lift into normal operation.

**⚠ DANGER** Each Lift Arm Assembly **must** be inspected and adjusted as required before each use. Do not operate the Lift if any of the four Lift Arm restraint systems are not functioning correctly. Replace any damaged components with approved replacement parts.

## Double Threaded Rod Installation

The Double Threaded Rods (5746167) as shown below, must be installed with M10 flat washers (5545341) and M10 x 1.5 Hex Nuts (5535013) on each Lift Post. Torque the Hex Nuts to 2-3 ft. lb. *Hydraulic Hoses are to be routed over the Tie Rods.*

**⚠ WARNING** The Double Threaded Rods must be installed to ensure proper operation of the Lift.



## Leveling

Before operating your Lift, you need to make sure the Lift Posts are straight, and the Lift Arms are level:

- **Lift Posts:** The Posts **must** be the same distance apart at the top and at the bottom.

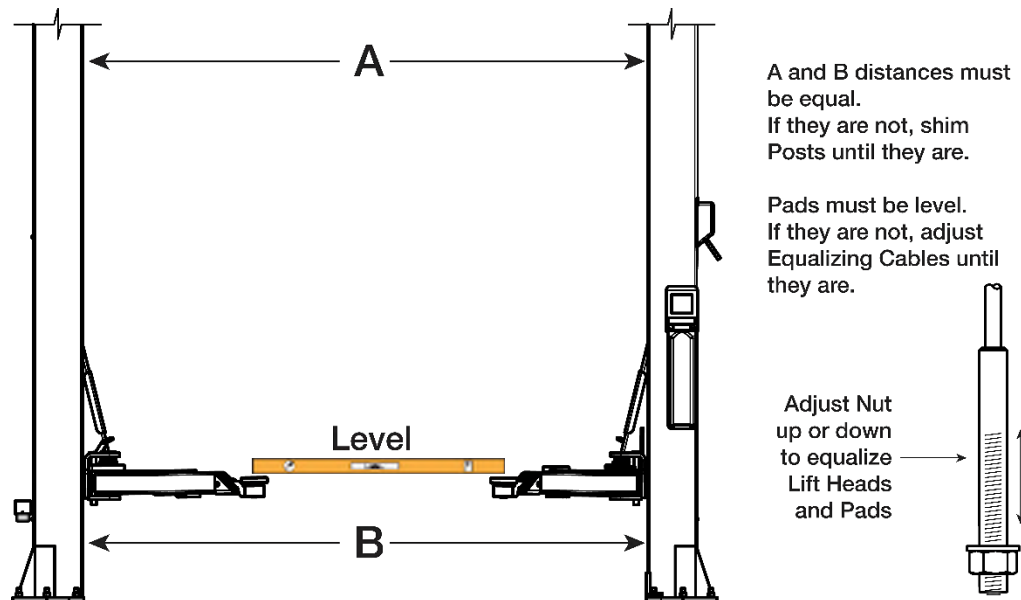
To make sure the Posts are straight, measure the distance between the two Posts six inches below the Overhead Assembly and one foot off the ground (you will need to move the Lift Arms out of the way). The two measurements (**A** and **B** in the drawing below) must be the same.

If the Posts are not straight, shim them as required.

- **CAUTION** If your Lift Posts are not straight or your Lift Arms are not level, this is a safety risk. The Vehicles you put on the Lift will be less secure; they could fall and cause injuries or damage to the Vehicle or to the Lift.

- **Lift Arms:** When the Lift Posts are straight, make sure the Lift Arms are level. Raise the arms to the first locking position and put a level across the Pads.

Adjust the Equalizing Cables. Determine which Lift Arm is low, then adjust the Nut on the bottom of the Threaded End of the Equalizing Cable until the Lift Arms are level. When you believe the Lift Arms to be level, raise the Lift and listen for the Lift Heads hitting the Safety Locks (there is a distinct thump). You want the thumps to be simultaneous or close to it.



- **NOTICE** If you have **not** yet torqued the Anchors you can torque them to specification (85 – 95 ft lb.) once you have completed final leveling.

---

## Contact the Electrician

As mentioned previously, there are installation tasks that require a certified Electrician.

**⚠ DANGER** All wiring **must** be performed by a licensed, certified Electrician in accordance with all applicable local electrical codes.

The Electrician needs to:

- **Connect to power.** The Power Unit comes with a pigtail for wiring to a power source. Have your Electrician connect a power cord with plug to the electrical box on the Lift (for connection to a power outlet) or have them wire it directly into the electrical system at the Lift location.
- **Connect the Microswitch to the Power Unit.** The Microswitch (which is next to the Safety Shutoff Bar) must be wired to the Power Unit. The necessary wiring is included.
- **Install a Power Disconnect Switch.** Ensures you can quickly and completely interrupt electrical power to the Lift in the event of an electrical circuit fault, emergency, or when equipment is undergoing service or maintenance. You must put it within sight and easy reach of the Lift operator. Refer to [Installing a Power Disconnect Switch](#) for more information.
- **Install a Thermal Disconnect Switch.** Ensures the equipment shuts down in the event of an overload or an overheated motor. Refer to [Installing a Thermal Disconnect Switch](#) for more information.

These installation tasks are described in detail in the following sections.

The Electrician is responsible for providing:

- A power cord and appropriate 220 VAC plug for connecting to an appropriate power source or the items required to connect to the facility's power system
- a Power Disconnect Switch
- a Thermal Disconnect Switch

Additional information is supplied in the following sections describing these tasks.

## Electrical Information

**⚠ DANGER** All wiring **must** be performed by a licensed, certified Electrician in accordance with all applicable local electrical codes. Do not perform any maintenance until main electrical power has been disconnected from the Lift and cannot be re-energized until all procedures are complete.

Important electrical information:

- Improper electrical installation can damage the Power Unit motor, which is not covered by the warranty.
- The Lift uses electrical energy; if your organization has Lockout/Tagout policies, make sure to implement them after connecting to a power source.
- Use a separate circuit breaker for each Power Unit.
- Protect each circuit with a time delay fuse or circuit breaker:
  - For a 208 to 230 VAC, **single phase** circuit, protected by an appropriate fuse or circuit breaker for the power unit delivered with the Lift.

## Wiring the Microswitch

This section describes how to wire the Microswitch; *installing* the Microswitch was described in [Installing the Microswitch](#).

The Lift comes with either one or two Microswitches, depending on the Power Unit:

- **1 Ph Power Units.** You need only one Microswitch, which must be wired between incoming power and the Electrical Box on the Power Unit on one of the two “hot” wires.
- **3 Ph Power Units.** You need two Microswitches, which must be wired between incoming power and the Electrical Box on the Power Unit on two of the three hot wires. Both Microswitches you receive are identical. If wiring *two* Microswitches, they **must** be wired on two **different** hot wires.

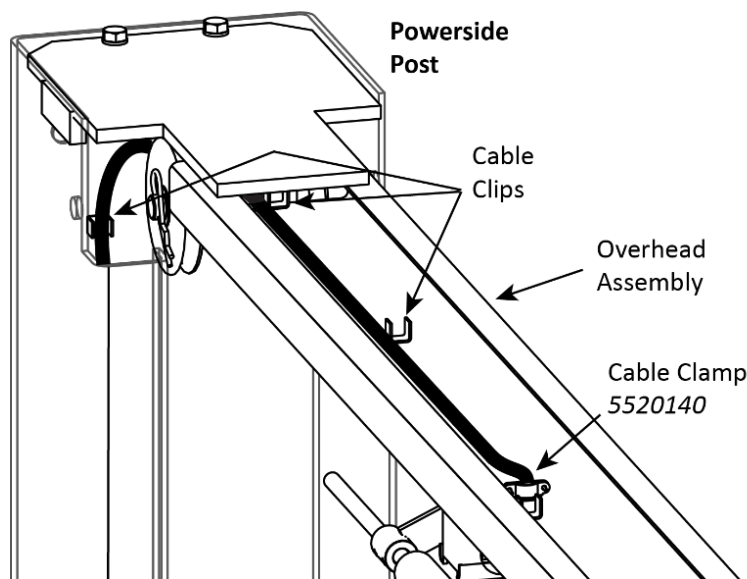
Refer to the diagrams in [Wiring Diagrams](#) for detailed Microswitch wiring information.

The following procedure assumes the Microswitch is already in place. If it is not, refer to [Installing the Microswitch](#) to install it.

### To wire a Microswitch to the Lift:

1. Locate the Microswitch Cable (14/4 SJO, UL 62, 300 VAC) supplied with the Lift.
2. **On the Overhead Assembly**, connect one end of the Microswitch Cable to the Microswitch (or two Microswitches, for a 3 Ph Power Unit). Refer to [Wiring Diagrams](#) for wiring information.
3. Route the Microswitch Cable from the Microswitch on the Overhead Assembly over to the Powerside Post, down the Powerside Post, out the hole in the Post near the top of the Safety Lock Release, and to the Electrical Box on the Power Unit.

**NOTICE** The Microswitch Cable and the Short Hydraulic Hose must go **around** the Powerside Safety Cover.



4. Once the Microswitch Cable is routed from the Microswitch to the Power Unit, clip the Microswitch Cable using the clips on the Overhead Assembly and the inside of the Powerside Post.  
Clipping the Microswitch Cable in place keeps it out of the way of the other components.
5. **On the Power Unit**, open the Electrical Box and wire the Microswitch Cable per the instructions in [Connecting the Power Unit](#).

## Connecting the Power Unit

The Power Unit and the Microswitch must be connected to an appropriate power source.

**⚠ DANGER** All wiring **must** be performed by a licensed, certified Electrician. Do not perform any maintenance or installation on the Lift without first making sure that main electrical power has been disconnected from the Lift and cannot be re-energized until all procedures are complete. The Lift uses electrical energy; if your organization has Lockout/Tagout policies, make sure to implement them after connecting to a power source.

**⚠ DANGER** Make clear to the Electrician that all electrical work **must** conform to applicable local, state, and federal codes, rules, and regulations, such as state and federal OSHA regulations and electrical codes.

Your 10AP Series Lift is available with one of any of the following types of Power Units:

- **220 VAC, 60 Hz, 1 Phase.** 220 VAC, for North American countries (U.S., Mexico, Canada).
- **208-240/380/460 VAC, 50/60 Hz, 3 Phase.** 3 Phase, multiple voltages available.
- **220 VAC, 50/60 Hz, 1 Phase.** 220 VAC, for countries *outside* North America.

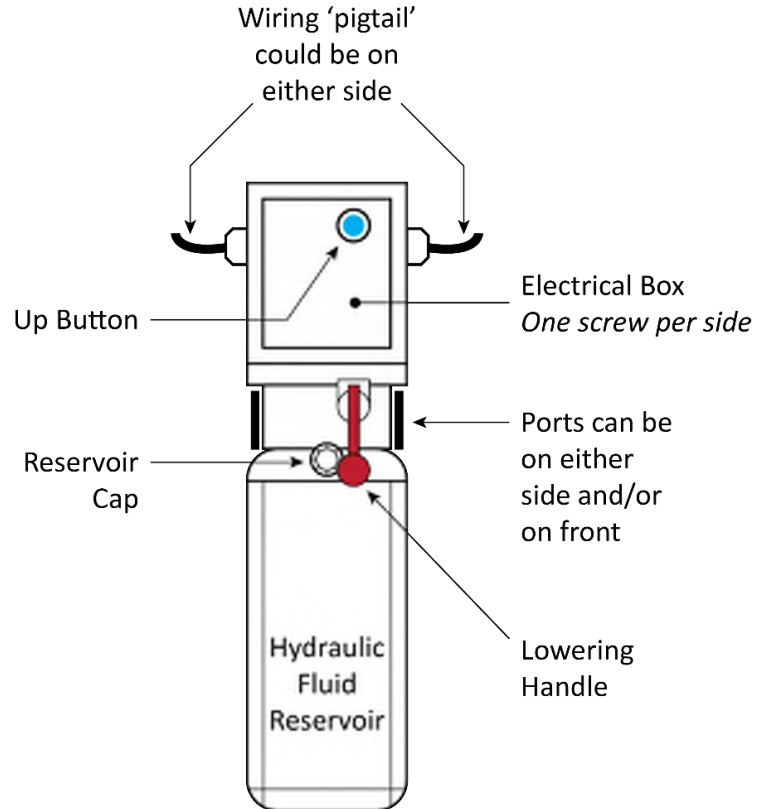
**NOTICE** 110 VAC Power Units are currently **not** available for 10AP Series Lifts.

The following drawing is a front view of a Power Unit. Your specific Power Unit may look somewhat different based on what type you purchased.

**Note:** The **Up** Button shown in the drawing above could be in a different location on the unit or could be a switch instead of a button, depending on the Power Unit you have.

**⚠ DANGER** Make clear to your Electrician that all electrical work **must** conform to applicable local, state, and federal codes, rules, and regulations, such as state and federal OSHA regulations and electrical codes.











**NOTICE** Wiring information is either on the outside of the Power Unit under the Electrical Box or inside the cover of the Electrical Box. Have the Electrician use that wiring information to wire the Power Unit to the power source.



---

## Hydraulic System Warnings

Before applying power to the Hydraulic System note the following Warnings:

-  **WARNING** Failure to observe these warnings can result in serious personal injury including, in rare cases, death.
-  **WARNING** The Hydraulic hoses and connections **must** be inspected before any attempt to raise a Vehicle is made.
-  **WARNING** Verify all Hydraulic Hose connections and fittings, including unused auxiliary port plugs on the Power Unit, the Flow Divider, the Cylinders and anywhere else in the Hydraulic System are tightened.
-  **WARNING** The Power Unit is a Hydraulic Pump capable of developing pressures in excess of 5,000 psi (345 BAR). A pressure relief valve is used to set the pressure at the desired level. Tampering with, adjusting, modifying, or removing the relief valve is extremely dangerous and is not recommended. Only trained Hydraulics technicians should adjust the relief valve, using calibrated hydraulic pressure gauges to assure the proper pressure setting is achieved.
-  **WARNING** Changes to the output pressure may render the power unit incompatible with pressure limitations of other components in the hydraulic circuit. This may cause catastrophic failure of those components, and could result in property damage, serious personal injury, or death.
-  **WARNING** The Hydraulic System may contain high pressure which, if suddenly released, can cause serious injury or death.
-  **WARNING** Do **not** attempt to connect or disconnect Hydraulic Hoses while the equipment is loaded or while a Vehicle is on the Lift, or the Hydraulic System is under pressure.
-  **WARNING** Keep bare hands away from Hydraulic Fluid; always wear gloves when handling Hydraulic Fluid, Cylinders or Hydraulic Hoses.
-  **WARNING** When handling Hydraulic Fluid, always observe the safety instructions from the manufacturer.
-  **WARNING** **Always** promptly clean any Hydraulic Fluid spills. If a leak is the source of the spill, lockout the Lift to prevent use until the Hydraulic System is repaired.

### To prepare the Power Unit:

1. Have the Electrician locate the Pigtail coming out of the Electrical Box on the Power Unit.
2. Open the Electrical Box, remove the Pigtail, and then either:
  - Wire the Power Unit directly into the facility's electrical system and protected by an appropriate circuit breaker.
  - Wire a power cord (with appropriate plug) *inside the Electrical Box* to the wiring that was connected to the Pigtail.
3. Wire the Microswitch(es) into the incoming power. Refer to **Wiring Diagrams** for wiring information.

4. Fill the Hydraulic Fluid reservoir with approved Hydraulic Fluid. When you receive the Power Unit, the Reservoir is empty; you need to fill it.

The reservoir holds **≈3.5 gallons** of Hydraulic Fluid, depending on which Power Unit you have.

Approved Hydraulic Fluids are any general-purpose ISO-32, ISO-46, or ISO-68 hydraulic oil or approved automatic transmission fluids such as Dexron III, Dexron VI, Mercon V, Mercon LV, Shell Tellus S4 / S3 / S2, or any synthetic multi-vehicle automatic transmission fluid.

**⚠ WARNING** Do not run the Power Unit without Hydraulic Fluid; you will damage it.

**⚠ DANGER** **Risk of explosion:** This equipment has internal arcing or parts that may spark and should not be exposed to flammable vapors. The Power Unit's motor should not be located in a recessed area or below floor level. Never expose the motor to rain or other damp environments; damage to the motor caused by water is not covered by the warranty.

## Installing a Power Disconnect Switch

**⚠ WARNING** A Power Disconnect Switch is **not** provided with this equipment.

A Power Disconnect Switch is a National Electrical Code (NEC) requirement. They are designed to allow the operator to interrupt the main electrical power in the event of an emergency or circuit fault, or when the equipment is undergoing service or maintenance.

Make sure to install a Power Disconnect Switch that is properly rated for the incoming power source.

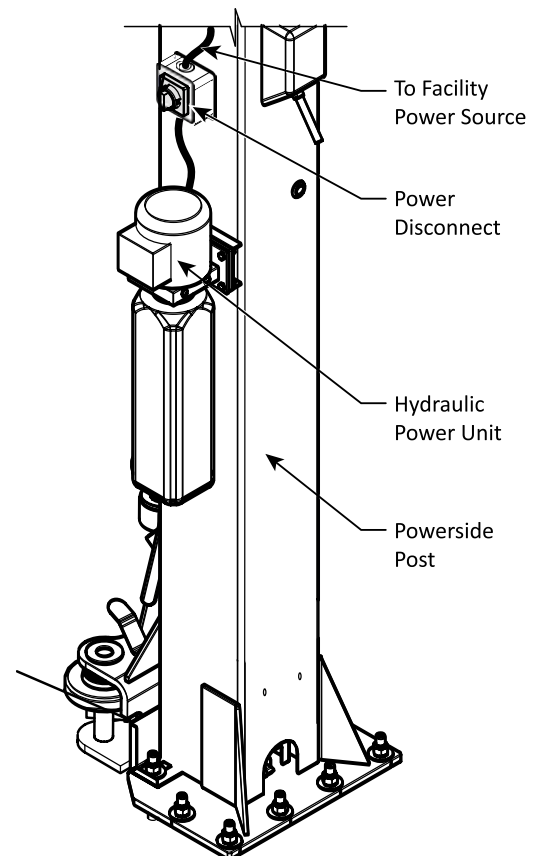
Your Power Disconnect Switch must be readily accessible and installed so that it is in easy reach of the operator or in their line of sight. The Power Disconnect Switch must be clearly marked to indicate its purpose.

The figure to the right details a Power Disconnect Switch located between the Lift's power source and its Power Unit. A quick flip of the switch immediately cuts power to the Lift.

In the case of the 10AP Series Lifts, the location directly above the Power Unit is being used by the Lowering Handle, so your Electrician may want to move the Power Disconnect Switch location up a little.

**⚠ DANGER** Installing a Thermal Disconnect Switch **must** be performed by a licensed, Electrician in accordance with local and national electrical codes.

Have the Electrician select a **UL-listed** Power Disconnect Switch.



## Installing a Thermal Disconnect Switch

**⚠ WARNING** A BendPak 10AP Series Lift motor has **no** thermal overload protection.

Have the Electrician connect a motor Thermal Disconnect Switch or overload device that will make sure the equipment shuts down in the event of an overload or an overheated motor.

**⚠ DANGER** Installing a Thermal Disconnect Switch **must** be performed by a licensed, Electrician in accordance with national and local and electrical codes. Do not perform **any** maintenance or installation on the Lift without first making sure that main electrical power has been disconnected from the Lift and **cannot** be re-energized until all procedures are complete.

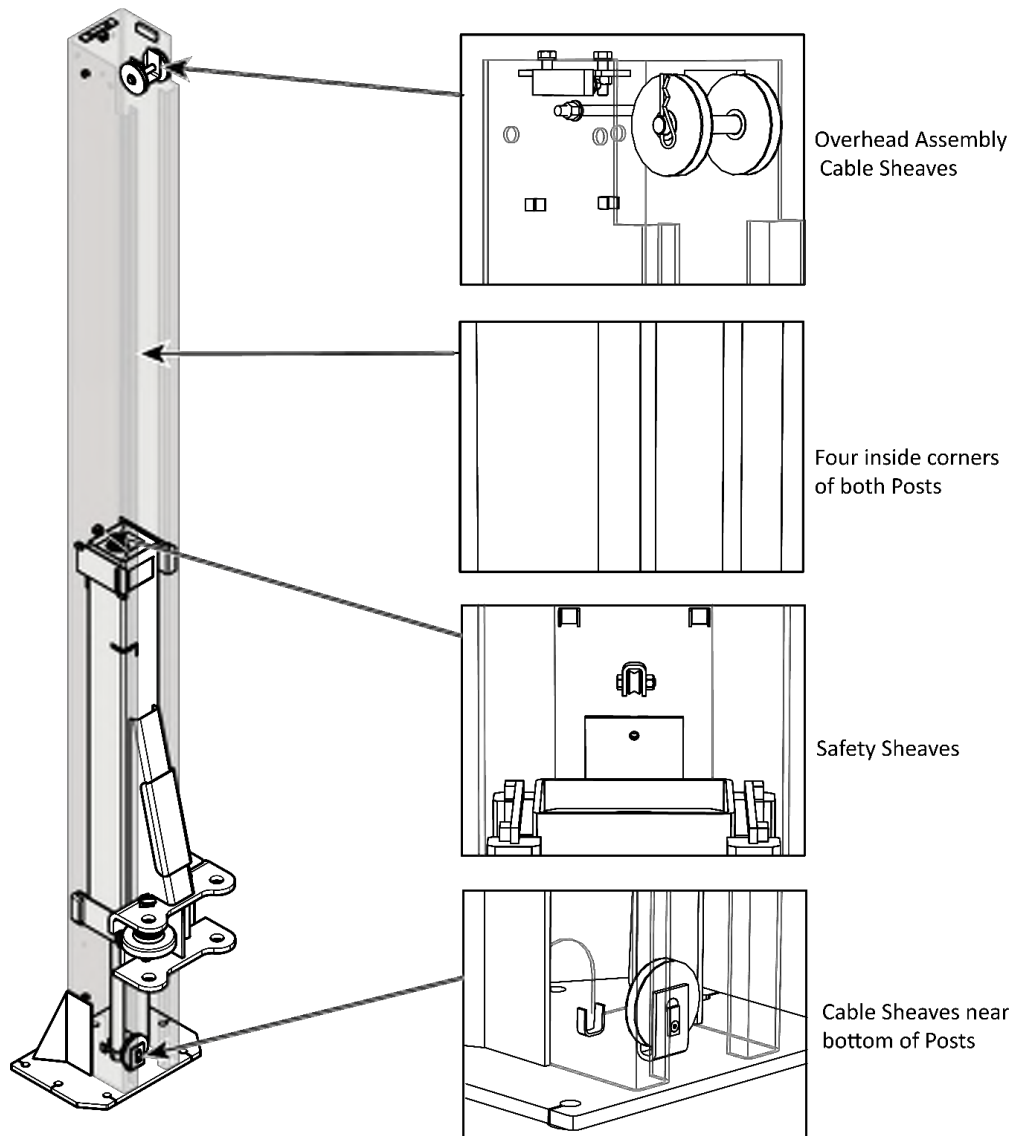
Running high electrical current that exceeds the motor's full load amps (FLA) rating may result in permanent damage to the motor.

BendPak strongly recommends you **not** exceed the rated duty cycle of the Lift motor.

## Lubricating the Lift

Lubricate the following with a white lithium grease or similar:

- All Cable Sheaves and Cable Sheave Pins on both Posts.
- The four inside corners of both Posts
- All Safety Sheaves
- All Lift Arm Pivot Points





---

## Review Final Checklist Before Operation

Make sure these things have been done before putting the Lift into normal operation:

- Review the **Installation Checklist** and verify all steps have been performed.
- Make sure the Power Unit is getting power from the power source.
- Check the Hydraulic Fluid reservoir; it must be full of approved Hydraulic Fluid or automatic transmission fluid. **You can harm the motor by running it without enough fluid.**
- Check the Hydraulic System for leaks. Verify all Hydraulic Hose connections, Hydraulic Fittings, and Auxiliary Port Plugs on the Lift and Power Unit are tight.
- Make sure both Posts are properly plumbed, shimmed, and stable.
- Check to see that all Anchor Bolts are correctly torqued.
- Lubricate all Cable Sheaves and the inside of the Posts where the Slide Blocks move.
- Make sure both Carriage Bolts are in place and tightened near the top of both Posts.
- Make sure all Cables are properly positioned in their Sheaves.
- Make sure all Cable Sheave retaining pins and/or clips are secure.
- Make sure both Safety Assemblies are connected and working normally.
- Make sure the Cylinder Clamps are secured in place above the Hydraulic Cylinders.
- Make sure that all Safety Locks are clear and free.
- Make sure an Operational Test has been performed.

## Leave the Manual with the Owner/Operator

Make sure to leave the *Installation and Operation Manual* with the owner/operator so that it is available to everyone who is going to use the Lift.



## Perform an Operational Test

Before putting your Lift into normal operation, we recommend raising and lowering it several times with a typical Vehicle on the Lift. This will help you get a feel for how to operate the controls and help get any residual air out of the Hydraulic System (sometimes called “bleeding” the system).

**⚠ DANGER** Automotive Lifts are dangerous tools when used by inexperienced or impaired technicians. When you even hear the words “automotive lift,” your brain should automatically register the fact that lifting a Vehicle is a serious endeavor with life-threatening risks if mandatory lifting precautions are ignored.

During the Operational Test, check for proper installation and operation. Do not raise any additional Vehicles until a thorough Operational Test has been done with a typical Vehicle.

**⚠ WARNING** Never raise a Vehicle whose weight exceeds the rated capacity of the Lift. Do not leave the controls until the Lift is engaged on its Safety Locks. Only trained personnel should raise or lower the Lift.

---

## To perform an Operational Test:

1. Make sure you have covered all the areas in **Review Final Checklist before Operation** before proceeding further.
2. Follow the instructions in **Raising a Vehicle** and **Lowering a Vehicle** to safely raise and lower a Vehicle on the Lift.

**⚠ DANGER** Follow the instructions carefully when it comes to contacting the manufacturer's recommended Lifting Points on the underside of the Vehicle. If you do not, the Vehicle could become unstable and fall, which could damage the Vehicle, damage the Lift, and injure or even kill anyone under the Vehicle.

3. Adjust the Lift Arms under the Vehicle so the Lift Pads are directly under the Lifting Points for the Vehicle you are raising. If necessary, use Auxiliary Adapters (**see Optional Accessories**) for additional height.
4. Press the **Up** button to raise the Lift until **just before** the Lift Pads contact the Lifting Points.
5. Check the Arm Restraint Gears on all four Lift Arm Assemblies to verify they are engaged. If they are not engaged, move the Lift Arms back and forth until they engage.
6. Raise the Lift until the tires of the Vehicle are a few inches off the ground.
7. Verify all four Lift Pads are making solid contact with all four Lifting Points.

If any of the Lift Pads are **not** making solid contact with the Lifting Points, carefully lower the Lift and start over again; the Lift Pads **must** make solid contact with all Vehicle Lifting Points.

8. Raise the Vehicle approximately three feet off the ground, then release the **Up** button, then *press and hold* the Safety Lock Release Handle and the Lowering Handle to lower the Lift back down.

**NOTICE** Residual air in the Hydraulic System can cause the Lift to shake, move erratically, or squeak; this is normal when you first start using the Lift. It will soon stop doing this, as the Hydraulic System is self-bleeding.

9. Wait for one minute.

**⚠ WARNING** The Power Unit is not a constant duty motor; **it cannot be run continuously.**

10. Repeat the process, this time raising the Lift, engaging it on a Safety Lock position, taking it off the Safety Lock position, and then lowering it back down to the ground.
11. If the Lift is working without shaking, moving erratically, or squeaking, there is no need to repeat the procedure. If the Lift is shaking, moving erratically, or squeaking, repeat the procedure one more time. If you continue to have issues, refer to **Troubleshooting** for assistance.
12. When the Lift is on the ground and the Vehicle is on all four tires, move the four Lift Arms to their full drive-through positions, then drive the Vehicle out.
13. With no Vehicle on the Lift Arms, press and hold the **Up** button on the Power Unit.
14. Have another person push up the Safety Shutoff Bar until it triggers the Microswitch.


If the Lift Arms do not stop rising when the Microswitch is triggered, the Microswitch is either not installed correctly or not wired correctly. Return to the sections in this manual where installation and wiring of the Microswitch is described to identify and correct the issue.

**⚠ CAUTION** Do not put the Lift into normal operation until you have confirmed that triggering the Microswitch stops the Lift Arms from rising.


---

# Operation

This section describes how to operate your BendPak 10AP Series Lift.

 **DANGER** Automotive Lifts are dangerous tools when used by inexperienced or impaired technicians. When you even hear the words “automotive lift,” your brain should automatically register the fact that lifting a Vehicle is a serious endeavor with life-threatening risks if mandatory lifting precautions are ignored.


## Lift Operation Safety Rules


 **DANGER** Your safety depends on reading, understanding, and implementing these Safety Rules. Do not skip over them; read them carefully and follow them!

Do the following **before** you raise or lower a Vehicle on your Lift:

**Check the Lift.** A complete inspection of the Lift is required before using it. Check the Hydraulic System for loose connections including Hydraulic Fittings, Hydraulic Hoses, and any Auxiliary Port Plugs. Check the Lift for any missing, heavily worn, or damaged parts. Do not operate the Lift if you find any issues; instead, take it out of service, contact your dealer, email [support@bendpak.com](mailto:support@bendpak.com), or call **(800) 253-2363**, option 7 then 4.

- **Check the area.** Keep the area around the Lift clean and free of obstructions; anything that could cause a problem for the Lift. Do not forget to check **above** the Lift. If you find an obstruction, move it out of the way. Do not allow any people or animals within 30 feet of the Lift while it is in motion.
- **Check the operators.** Make sure that everyone who is going to operate the Lift has been trained in its use, has read the labels on the unit, and has thoroughly read the manual and understands how this equipment works. Only the operator should be within 30 feet of the Lift when it is in motion. Do not allow children to operate the Lift. Do not allow anyone under the influence of drugs or alcohol to operate the Lift.
- **Check for safety.** Make sure everyone who is going to be walking near the Lift is aware of its presence and takes appropriate safety measures. Only put Vehicles on the Lift Arms. **When raising a Vehicle on the Lift, do not leave it until it is positioned on Safety Locks.** When lowering the Lift, do not leave it until it is on the ground.
- **Check the Vehicle.** Never exceed the Lift’s weight rating. Do not allow people inside a Vehicle you are going to raise. Make sure the Vehicle is not overbalanced on either end. Make sure you know the manufacturer’s recommended Lifting Points for the Vehicle. Never raise just one side, one corner, or one end of a Vehicle.

 **WARNING** Always use care when you are around your Lift. When it is in a lowered position, be careful not to trip over it. When it is raised, be careful not to hit your head on the Lift Arms or the Vehicle. **When you are raising or lowering a Vehicle, keep all people, animals, and objects at least 30 feet away from the Lift.**

 **WARNING** Never place yourself or others under a raised Vehicle unless the Lift is engaged on its Safety Locks and the Vehicle is stable on the Lift. Always use Jack Stands to secure the Vehicle when work is under way or if removing components that will significantly change the Vehicle’s balance on the Lift.

## About Lifting Points, Adapters, and Auxiliary Adapters

An important point to keep in mind when using a frame-engaging Lift is that the raised Vehicle must be balanced on the four Lift Arms. If the Vehicle is not balanced, it is more likely to become unstable and slide off the Lift, possibly damaging the Lift, the Vehicle, and anything under the Lift, including injuring people.

**⚠ WARNING** You **must** use all four Lift Arms when raising a Vehicle. Never use just one, two, or three Lift Arms to raise a Vehicle. The Vehicle will be unstable and could slip off the Lift, possibly damaging the Lift, damaging the Vehicle, and injuring anyone under it.

To balance a Vehicle on a frame-engaging Lift, you need to have the Lift Pads (Adapters) contact the Vehicle on the manufacturer's recommended Lifting Points. When you raise a Vehicle by its Lifting Points, the Vehicle is balanced.

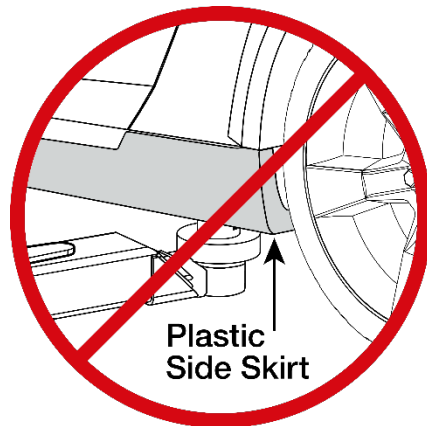
**NOTICE** The manufacturer's recommended Lifting Points do not take into consideration any major changes that might have been made to the Vehicle. If the motor is removed, for instance, or there is a 5,000 pound / 2,268 kg weight in the trunk, the Vehicle's Lifting Points will not be the best balancing points.

Some Vehicles have indicators on the underside that identify the manufacturer's Lifting Points; many do not.

Your best approach is to find the Vehicle in the guide provided with your Lift. *Vehicle Lifting Points for Frame Engaging Lifts* or contact the manufacturer of the Vehicle. This guide also includes a page of safe lifting suggestions, which everyone who uses the Lift should read.

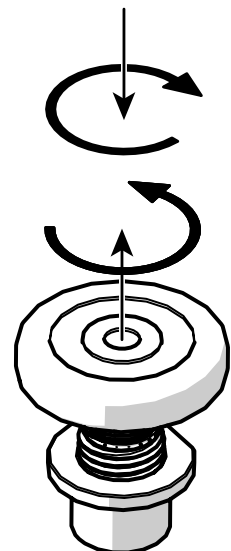
*Lifting it Right: A Safety Manual from the Automotive Lift Institute*, also provided with your Lift, includes a wide variety of information about Lifts and how to use them safely.

**⚠ DANGER** **Never** place Contact Pads on non-approved, non-load holding Sill Covers or Side Skirts!



### Standard Accessories

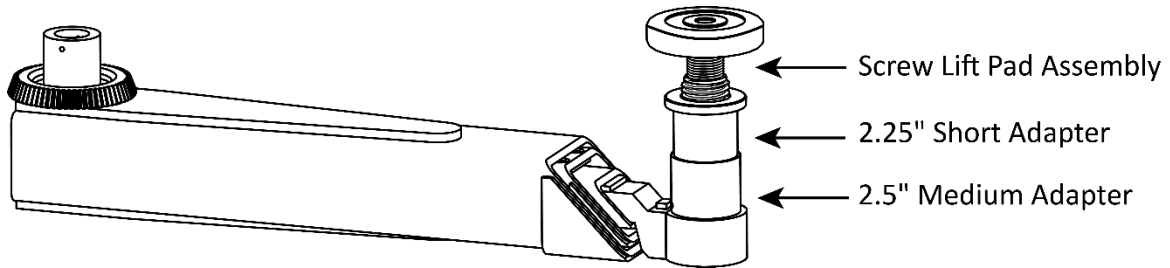
The 10AP is supplied with **Four Screw Lift Pad Assemblies** (5215704) Best suited for Vehicles with Unibody construction; they are height adjustable, up to 3-inches.



## Optional Accessories

Visit [bendpak.com](http://bendpak.com) for additional Adapters and Auxiliary Adapters (also called height adapters or extenders) available adapters include the following:

- **Four Short Auxiliary Adapters - 2.25 in. / 56 mm** (5215757). Allows you to position the height of your Auxiliary Adapters to make better contact with Vehicles.
- **Four Medium Auxiliary Adapters - 2.5 in. / 63 mm** (5215758). Allows you to position the height of your Auxiliary Adapters to make better contact with Vehicles.

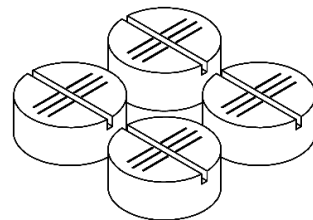
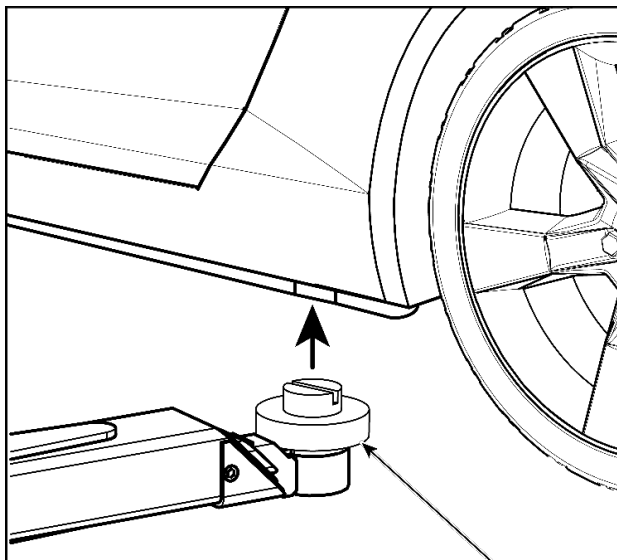


**⚠ WARNING** You can stack Auxiliary Adapters, but only up to 9 in. If you stack Auxiliary Adapters above 9 in., the Vehicle could become unstable and slip off the Lift, possibly damaging the Lift, damaging the Vehicle, and injuring anyone under it.

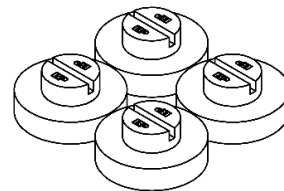
**⚠ WARNING** Use the correct Adapters. Do not attempt to lift trucks or other frame type vehicles with standard Rubber Contact Pads.

**⚠ WARNING** Never use the Lift with missing or damaged rubber Contact Pads. Always replace Rubber Contact Pads when worn or damaged.

**Quick-Fit Slotted Pinch-Weld Pucks or Pads** — Always use slotted Pinch-Weld Pucks (5210263) or slotted Pinch-Weld Pads (5210254) when lifting Vehicles on Manufacturer Approved Pinch-Weld Jacking Points. These convenient tear-resistant urethane Adapters simply fit over the existing round Contact Pads.



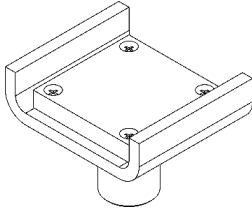
5210254 Set of 4 Slotted Pads



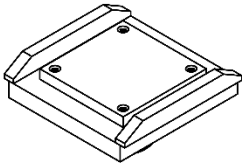
5210263 Set of 4 Slotted Pucks

**✓** Always use slotted Pads or Pucks when lifting Vehicles on OEM-approved Pinch Weld Jacking Points.

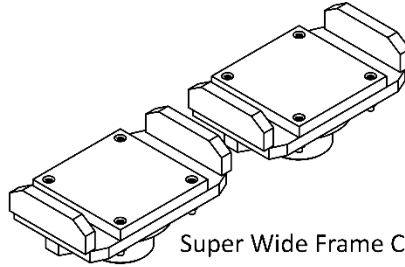
**Frame Cradle Adapters** — Required for use when lifting trucks, vans or other frame Vehicles that require additional stability. (5215761) Set of 4.



**Wide Frame and Super Wide Frame Cradle Adapters** — Recommended for use when lifting heavy-duty wide frame vehicles. **Wide Frame** version fits frames up to 5.25 in. / 133 mm (5215828). **Super Wide Frame** version fits frames up to 6.5 in. / 168 mm (5210253).

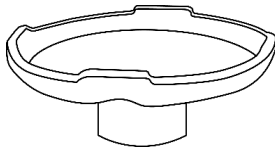


Wide Frame Cradle Adapter

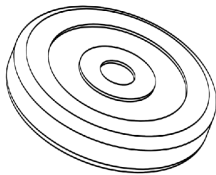


Super Wide Frame Cradle Adapter

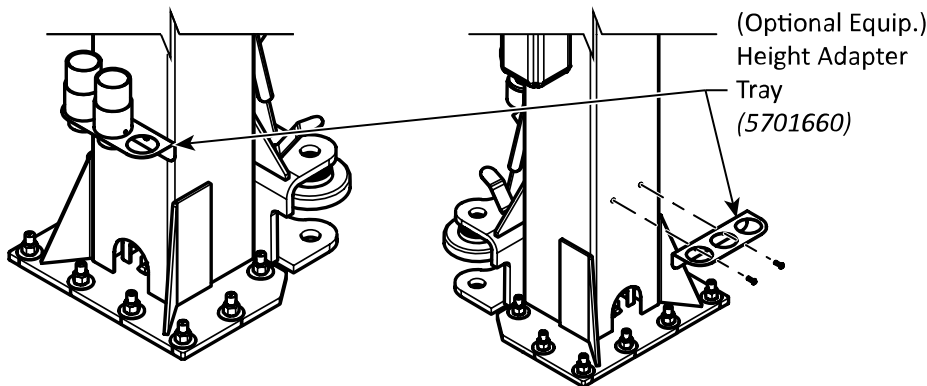
**Steel Lift Pads** — Recommended for additional stability on all vehicles. The flanged edges grip the chassis for an extra-secure hold. (5215763) Set of 4



**Replacement Polyurethane Tuf Pads™** — Never use your Lift with missing or damaged Rubber Contact Pads. Always replace Pads when worn or damaged, (5700227) set of 4.



**Adapter Tray** — Adapter Trays allow storage of Auxiliary Adapters conveniently near the Lift Arms.




Visit [BendPak.com](http://BendPak.com) for accessories and replacement Parts information at **(800) 253-2363**, press option 7, then 5; please have the model and serial number of your Lift available.

---

## Raising a Vehicle


This section describes how to raise a Vehicle on your 10AP Series Two-Post Lift.

 **WARNING** Never raise a Vehicle whose weight exceeds the rated capacity of the Lift. Do not leave the controls until the Lift is engaged on a Safety Lock position or fully lowered. Only trained personnel should raise and lower the Lift.


### To raise a Vehicle:

1. Verify all four Lift Arms are on the ground in their full drive-through positions and all personnel are clear of the service bay.
2. Check under the Vehicle you are going to raise, check for the type of vehicle frame, and then put the most appropriate Pads/Adapters on the Lift Arms.

If you are lifting a sedan or a Vehicle with a unibody construction, a Screw Lift Pad is generally the best choice. If you are lifting an SUV, truck, or other Vehicle with a frame construction, a Frame Cradle Pad is generally the best choice.

 **WARNING** Always use the Pad/Adapter type best suited for the Vehicle you are raising. If you use the wrong Adapter type, the Vehicle could become unstable on the Lift.

3. Drive the Vehicle into the service bay.

 **CAUTION** When driving a Vehicle into position, keep to the middle of the area between the Posts. If you hit a Lift Arm or any other portion of the Lift, you could damage the Vehicle and/or the Lift.


4. When you are satisfied with the location of the Vehicle, put it in park, engage the parking brake, and turn off the motor.


If the Vehicle is a manual transmission, put it into first gear before turning off the motor.

5. Get out of the Vehicle; open the doors carefully to avoid damaging them on the Lift.
6. Locate the manufacturer's recommended Lifting Points for the Vehicle you are raising.

If you are unsure where the Lifting Points are, consult *Vehicle Lifting Points for Frame Engaging Lifts*, which was provided with the Lift, or the manufacturer of the Vehicle. If you no longer have *Vehicle Lifting Points for Frame Engaging Lifts*, contact BendPak Support email [support@bendpak.com](mailto:support@bendpak.com) or call **(800) 253-2363**, option 7 then 4, to secure a replacement copy.

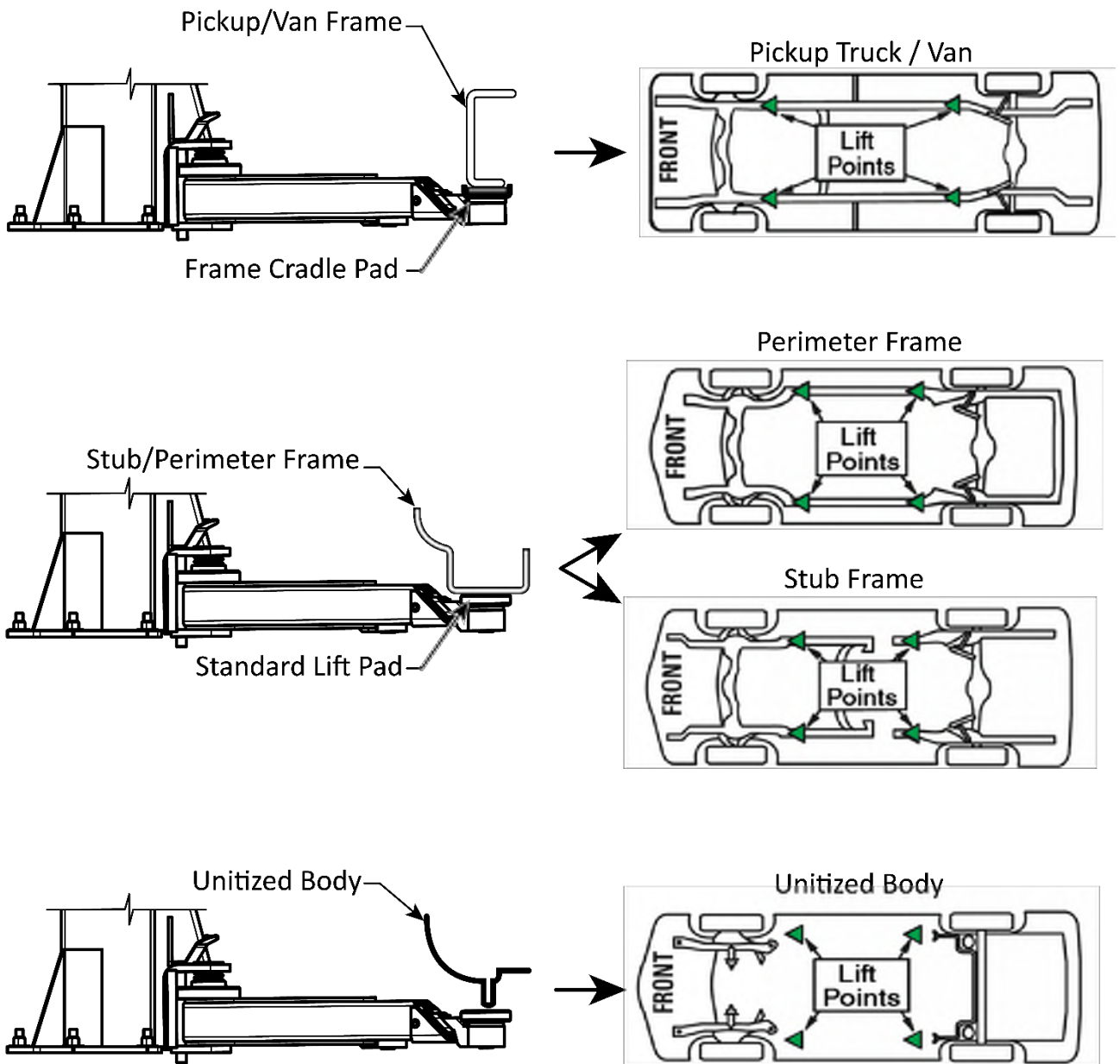
Some Vehicles may have the manufacturers' recommended Service Garage Lift Point locations identified by a triangle mark on the underside of the Vehicle, reference SAE J2184- (Current Edition). On some Vehicles, specific Lifting Points are indicated by a label located on the driver's side door jamb.

 **WARNING** Do not 'eyeball' the best location for the Pad/Adapters. **You must use the manufacturer's recommended Lifting Points.** If you do not, the Vehicle could become unstable and fall, which could damage the Vehicle, damage the Lift, or injure or even kill anyone under the Vehicle.

 **WARNING** Many specialty or modified Vehicles or Vehicles with unusually short or long wheelbases cannot be on raised on a Two-Post Frame Engaging Lift. Contact the Vehicle's manufacturer for Raising or Jacking guidance.

The figure on the next page illustrates typical lifting points based on Vehicle Frame type.

### Typical Lifting Points



**⚠ WARNING** Before attempting to lift a Vehicle verify:

- The Vehicle Frame is strong enough to support its weight and has not been weakened or compromised by modification, damage, or corrosion.
- The Vehicle individual axle weight does not exceed one-half the Lift capacity.
- All- Lift Pads/Adapters are in secure contact with the Frame at the Vehicle manufacturers' recommended Lift Points.
- The Vehicle is stable on the Lift and the center of gravity is not shifted, making the Vehicle off balance.
- The overhead switch bar will contact the highest point on the Vehicle.



**⚠ WARNING** Always use Safety Stands when removing or installing heavy components that may affect the Vehicle's Center of Gravity.

7. Adjust the Lift Arms under the Vehicle until the Pads/Adapters are **directly under** the Lifting Points for the Vehicle you are raising. If necessary, use the included Auxiliary Adapters for extra height.

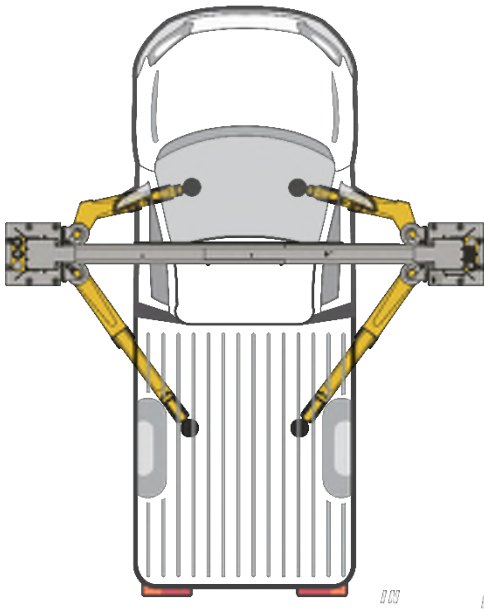
The Vehicle's Lifting Point locations and Center of Gravity will determine if the Lift is configured in an Asymmetric or Symmetric Configuration.

In an Asymmetric Configuration the Centerline of the Vehicle is behind the Lift Posts.

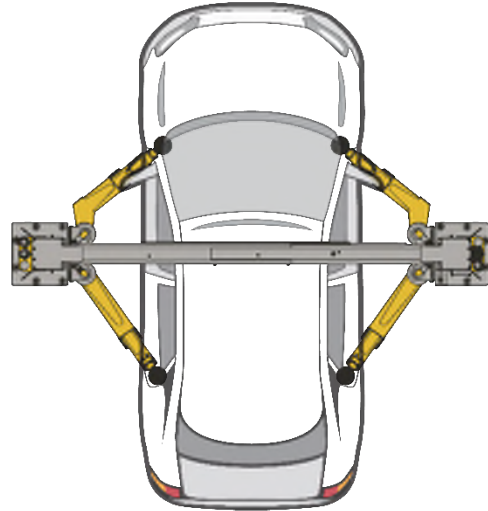
In a Symmetric Configuration the centerline of the Vehicle is lined up at the Lift Posts.

Refer to the figure below.

Asymmetric Configuration



Symmetric Configuration



*Reference only – do not scale.*

8. Raise the Lift until **just before** the Pads/Adapters contact the Lifting Points.
9. Check the Arm Restraint Gears on all four Lift Arms to make sure they are engaged.  
If they are not engaged, move the Lift Arms back and forth until they engage.
10. Raise the Lift until the tires of the Vehicle are a few inches off the ground.
11. Verify all four Pads/Adapters are making solid contact with the Lifting Points.  
If any of the Pads/Adapters are **not** making solid contact with the Lifting Points, carefully lower the Lift and start over again; the Pads/Adapters **must** make solid contact with all Lifting Points.
12. Gently rock the Vehicle to make sure the Vehicle is stable and balanced.
  - If the Vehicle is **not** stable and balanced, lower the Lift back to the ground and start over.
  - If the Vehicle **is** stable and balanced, you can raise it to the desired height.

**⚠ DANGER** Do not raise the Lift further until you are certain the Vehicle on the Lift is both stable and balanced. If the Vehicle is **not** stable and balanced, it could fall, which could damage the Vehicle, damage the Lift, as well as injure or kill anyone under the Vehicle.

**⚠ WARNING** Always keep a line of sight on the Lift. Ensure personnel and objects are always clear of the Lift.

**⚠ WARNING** Remain Clear of the elevated Lift until visual confirmation is made that all Safety Locks are fully engaged, and the Lift is lowered onto the Safety Locks.

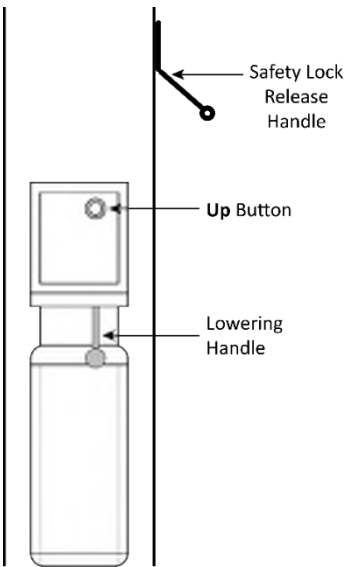
13. Press and hold the **Up** Button.
14. Listen as the Lift passes the Safety Locks; you should hear a thump as each side passes by the Safety Locks at approximately the same time.
15. When the Vehicle reaches the desired height, go past the next Safety Lock position (you will hear the thump as it passes), then release the **Up** Button.
16. *Press and hold* the Lowering Handle, which lowers the Lift onto the Safety Lock position you just passed. Do **not** hold the Safety Lock Release Handle, which is for lowering the Lift to the ground.
17. When the Lift stops moving down, it is engaged on its Safety Locks; release the Lowering Handle.

**Do not leave the Lift controls unless the Lift is engaged on its Safety Locks or fully lowered.**

18. Recheck the Pads/Adapters to make sure they are all still making solid contact with the Lifting Points.
19. Verify the Lift is engaged on the **same Safety Lock** on both Posts.

**⚠ DANGER** Always ensure both Safety Locks are engaged. If the Lift Heads are engaged on Safety Locks at two different heights or only one Safety Lock is engaged, the Vehicle could become unbalanced and fall causing damage, injury, or death.

20. Begin work on the Vehicle.

<p><b>To raise the Lift:</b></p> <ol style="list-style-type: none"> <li>1. Press and hold <b>Up</b> Button.</li> <li>2. When Lift is just past desired height, release <b>Up</b> Button.</li> <li>3. Press and hold Lowering Handle.</li> </ol> <p><i>Do not pull down the Safety Lock Release Handle. If you do, the Lift will continue to lower and will not engage on its Safety Locks. Lift engages on its Safety Locks and stops moving; release Lowering Handle when Lift stops.</i></p> <p><i>Only leave the Lift on Safety Locks or fully lowered.</i></p>	 <p>The diagram shows a vertical lift column with two control handles. The 'Up Button' is a circular button on the upper part of the column. The 'Lowering Handle' is a horizontal handle on the lower part of the column. The 'Safety Lock Release Handle' is a handle on the right side of the column, positioned higher than the Lowering Handle. Arrows point from the text labels to the corresponding handles in the diagram.</p>	<p><b>To lower the Lift:</b></p> <ol style="list-style-type: none"> <li>1. Press and hold <b>Up</b> Button for two to three seconds. This moves Lift off its Safety Locks.</li> <li>2. Pull down and hold Safety Lock Release Handle <b>and</b> Lowering Handle. Lift begins lowering.</li> <li>3. When Lift is fully lowered, release Safety Lock Release Handle and Lowering Handle.</li> </ol> <p><i>Only leave Lift on Safety Locks or fully lowered.</i></p>
--	---	---

---

## Lowering a Vehicle

To lower a Vehicle off the Lift, first raise it a small amount to get it off its Safety Locks, then lower it.

### To lower a Vehicle off the Lift:

1. Check under and around the Vehicle to make sure the area is clear of all obstructions.  
If you find any obstructions, **move them out of the way.**
2. Press and hold the **Up** Button for a second or two to move the Lift off its Safety Locks.  
Raise the Lift at least two inches to get clear of the Safety Locks.
3. Pull down and hold the Safety Lock Release Handle (on the Powerside Post above and to the right of the Power Unit).
4. Push and hold the Lowering Handle (on the front of the Power Unit). The Lift begins lowering.

**NOTICE** Both the Safety Lock Release Handle **and** the Lowering Handle must be held down at the same time to lower the Lift.

**⚠ WARNING** Do not override the Lift controls. For safety purposes, Lift controls are designed to stop the Lift if released. Overriding the Lift controls could lead to damage to the Lift, damage to the Vehicle on the Lift, injury, or in rare cases, death to persons near the Lift.

**⚠ CAUTION** Remain clear of the Lift as it comes down; obey the pinch point warning decals.

5. When the Lift is on the ground, release both Handles, then move all four Lift Arms to their full drive-through positions to allow an unobstructed exit for the Vehicle.
6. Carefully drive the Vehicle out.

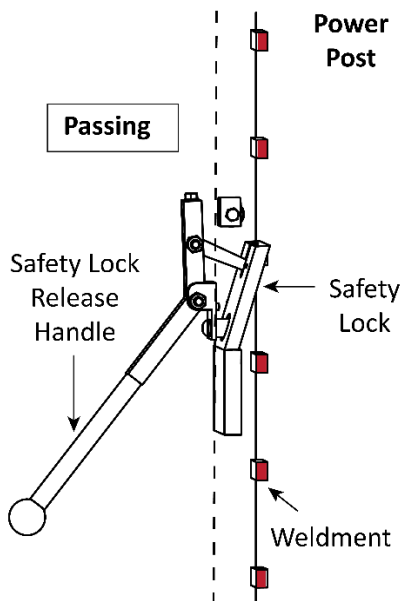
## About Safety Locks

A Safety Lock **position** is defined as when the Lift is engaged on both Lift's Safety Locks at the same height on both Posts. Having multiple Safety Lock positions allows you to lock the Lift at the best height for what you need to do.

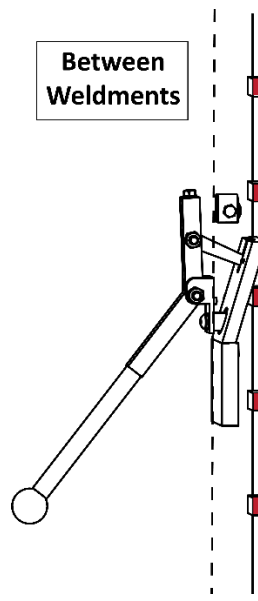
**⚠ CAUTION** Verify that both Safety Locks are engaged at the same height on both Posts. You do not want the Lift engaged on Safety Locks of two different heights or the Safety Lock on one Post engaged but the Safety Lock on the other Post not engaged.

Safety Lock positions are created by the Safety Lock Weldments, which are on the back of each Lift Head. Safety Lock Weldments hit the Safety Locks and then move past them as the Lift Heads rise.

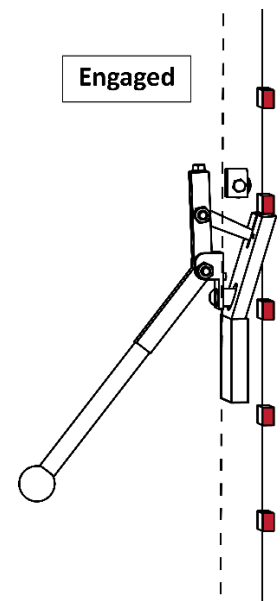
**Passing:**



**Between Weldments:**



**Engaged:**



*Components removed for clarity. Offside Safety Lock not shown. Reference only – do not scale.*

As they move past the Safety Locks, the Weldments push the Safety Lock and the Safety Lock Release Handle down. When the Weldment is completely past the Safety Locks, the Safety Lock Spring pulls the Lock back into place. This happens each time Safety Locks are passed, so you will generally be hearing multiple clanks as the Lift rises and lowers.

To engage the Lift on a Safety Lock position, press the **Up** Button and wait until the Vehicle reaches the desired height for the work you are going to do, then listen for the clank as the Weldments pass the next Safety Lock position. When you hear the clank, release the **Up** Button, and then hold down the Lowering Handle (on the front of the Power Unit) for a second or two to back the Weldments down onto the just-passed Safety Locks; **do not** hold down the Safety Lock Release Handle.

**⚠ WARNING** Only leave the Lift either fully lowered or engaged on Safety Locks. **If you leave the Lift raised but not engaged on Safety Locks, the Vehicle is not secure.** It could fall, possibly damaging the Vehicle, the Lift, and injuring anyone under the Vehicle.

---

# Maintenance

**⚠ DANGER** Before performing any maintenance on your 10AP Lift, verify it is completely disconnected from power. The Lift uses electrical energy; if your organization has Lockout/Tagout policies, make sure to implement them before performing any maintenance. If you come into contact with high voltage, you could be injured or killed.

Read your manual and understand how this equipment works before using, maintaining, or repairing. Routine maintenance and adjustments are the responsibility of the owner/user and are not covered under warranty.

Routine maintenance and adjustments should be carried out on a regular basis. *Unless stated otherwise, all maintenance may be performed by the owner/employer and does not require trained lift service personnel.* Replace worn, damaged or broken parts with original BendPak or BendPak approved parts or with parts that meet or exceed the original specifications.

## To maintain your Lift:

- **Daily:** Keep the 10AP clean. Wipe up any spills, clean any dirt.
- **Daily:** Make a visual inspection of all moving parts and check for damage or excessive wear. Replace any damaged or worn parts before using the Lift.

**⚠ DANGER** Do not use the Lift if the cables are damaged or extremely worn. If a Vehicle is raised when you notice the damage or extreme wear, very carefully lower the Vehicle to the ground. When the Lift is on the ground, remove it from service, disconnect it from power, and make arrangements for repair.

- **Daily:** Visually inspect that the Safety Locks are in good operating condition. Do not use your Lift if the Safety Locks are damaged or excessively worn.
- **Weekly:** Check all controls to make sure they are functioning normally.
- **Weekly:** Check all labels on the Lift. Replace them if they are illegible or missing.
- **Monthly:** Lubricate the Posts. BendPak recommends using white lithium grease or similar.
- **Monthly:** Check Hydraulic Fluid levels. Refill if low.
- **Monthly:** Check cable connections, bolts, and pins for proper mounting and torque.
- **Monthly:** Make sure all pivot arm pins are properly secure.
- **Every two months:** Check all Anchor Bolts to make sure they are correctly torqued. If they are not, torque them to 85 – 95 ft lb.
- **Every 3 Months:** Inspect and lubricate the Wire Rope, Guide Rollers, Sheaves and Pins.
- **Every three to five years or as needed.** Carefully check the Equalizing Cables every three to five years, or immediately if there are signs of damage or extreme wear. See **Wire Rope Inspection and Maintenance** for additional information.
- If the Lift becomes inoperative in a raised position, see the **Troubleshooting** section.
- The 10AP maximum operating hydraulic pressure developed upon lifting its maximum capacity of 10,000 lbs./ 4,536 kg. is 2,300 psi.

**⚠ WARNING** Do not operate your Lift if you find maintenance issues; instead, remove it from service and correct the maintenance issues. Technical support and service is available from your dealer, on the Web at [bendpak.com/support](https://bendpak.com/support), by email at [support@bendpak.com](mailto:support@bendpak.com), or by phone at **(800) 253-2363**, option 7 then 4. Online chat is also available at [www.bendpak.com](https://www.bendpak.com) click the chat icon.



---

## 10AP Wire Rope Inspection and Maintenance

The 10AP wire ropes should be inspected regularly:

- Lifting cables should be replaced when there are visible signs of damage or extreme wear. **Do not use the Lift if it has damaged or worn cables.**
- Lifting cables should be always maintained in a well-lubricated condition.

Wire rope is fully protected when each wire strand is lubricated both internally and externally. Excessive wear shortens the life of wire rope. Use a wire-rope lubricant that penetrates to the core of the rope and provides long-term lubrication between each individual strand, such as 90-WT gear oil or ALMASOL® Wire Rope Lubricant.

To make sure that the inner layers of the rope remain well lubricated, lubrication should be carried out at intervals not exceeding three months during operation.

- All sheaves and guide rollers in contact with the moving rope should be given regular visual checks for surface wear and lubricated to make sure they run freely. This operation should be carried out at appropriate intervals generally not exceeding three months during operation.

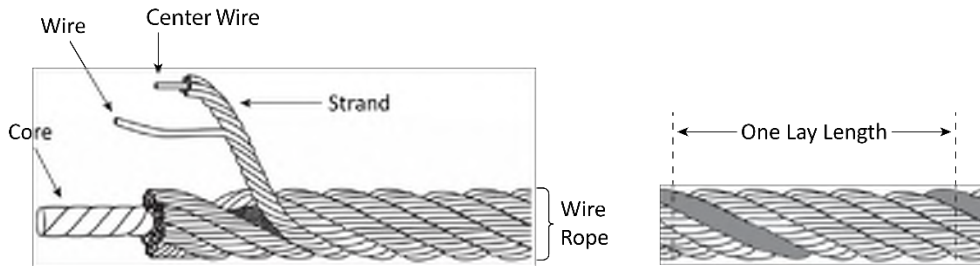
For all sheave axles, use standard wheel bearing grease. For all sheaves and/or guide rollers, use 90-WT gear oil or a similar heavy lubricant, applied by any method including pump/spray dispensing, brush, hand, or swabbing.

- How often should you inspect?

Lifting cables should be visually inspected at least once each day when in use, as suggested by American Petroleum Institute's Recommended Practice 54 guidelines. Any lifting cables that have met the criteria for removal must be immediately replaced.

- When should you replace lifting cables due to broken wires?

Lifting cables should be removed from service when you see six randomly distributed broken wires within any one lay length, or three broken wires in one strand within one lay length.



- Are there other reasons to replace your lifting cables?

Yes. Corrosion that pits the wires and/or connectors, evidence of kinking, crushing, cutting, bird-caging, or a popped core, wear that exceeds 10% of a wire's original diameter, or heat damage.

- How do you find broken wires?

- a. Relax your rope to a stationary position and move the pick-up points off the sheaves. Clean the surface of the rope with a cloth — a wire brush, if necessary — so you can see any breaks.
- b. Flex the rope to expose any broken wires hidden in the valleys between the strands.
- c. Visually check for any broken wires. One way to check for crown breaks is to run a cloth along the rope to check for possible snags.
- d. With an awl, probe between wires and strands and lift any wires that appear loose. Evidence of internal broken wires may require a more extensive rope examination.

# Troubleshooting

This section describes how to troubleshoot your Lift.

**NOTICE** If your Lift is not functioning correctly, you must take it out of service until it is fixed.

**Important:** Replace worn, damaged or broken parts with original BendPak or BendPak approved parts or with parts that meet or exceed the original manufacturer specifications.

**⚠ DANGER** Before performing maintenance on your Lift, verify it is disconnected from power. The Lift uses electrical energy; if your organization has Lockout/Tagout policies, implement them before performing any maintenance. If you come into contact with high voltage, you could be injured or killed.

Issue	Action to Take
Lift becomes inoperative in a raised position.	Verify there is sufficient Hydraulic Fluid in the reservoir. Verify the Lift Carriages are above and clear of the Safety Locks. Verify none of the Hydraulic Hoses are pinched or leaking. Verify the Power Unit is being supplied power. Make sure the Lift is not overloaded. Make sure the load on the Lift is balanced. Contact <a href="https://www.bendpak.com/support">bendpak.com/support</a> , or by phone at <b>(800) 253-2363</b> , option 7 then 4.
Arms move erratically or squeak when in use.	Move the Lift Arms up and down a few times to flush any residual air from the Hydraulic System.
Offside Lift Head will not lower.	See broken Safety Cable procedure below.
Lift does not stay up.	Make sure to leave the Lift engaged on its Safety Locks. Check for Hydraulic Fluid leaks.
Vehicle on Lift not level.	Make sure Lift is engaged on Safety Locks at the same height. Make sure the Safety Locks in both Posts are engaged. If either condition is not met, carefully lower the Vehicle back down to the ground and raise it again.
Motor not running.	Check connection to power source; make sure it is plugged in and the appropriate voltage. Check wiring diagram on Power Unit.
Hydraulic Fluid is dirty.	Replace the dirty Hydraulic Fluid with clean, approved ATF fluids, such as Dexron III, Dexron VI, Mercon V, Mercon LV, or comparable.
Lift makes odd noises.	Lubricate hinge points using white lithium grease.

Technical support and service is available from your dealer, on the Web at [bendpak.com/support](https://www.bendpak.com/support), by email at [support@bendpak.com](mailto:support@bendpak.com), or by phone at **(800) 253-2363**, option 7 then 4. Online chat is also available at [www.bendpak.com](https://www.bendpak.com) click the chat icon.

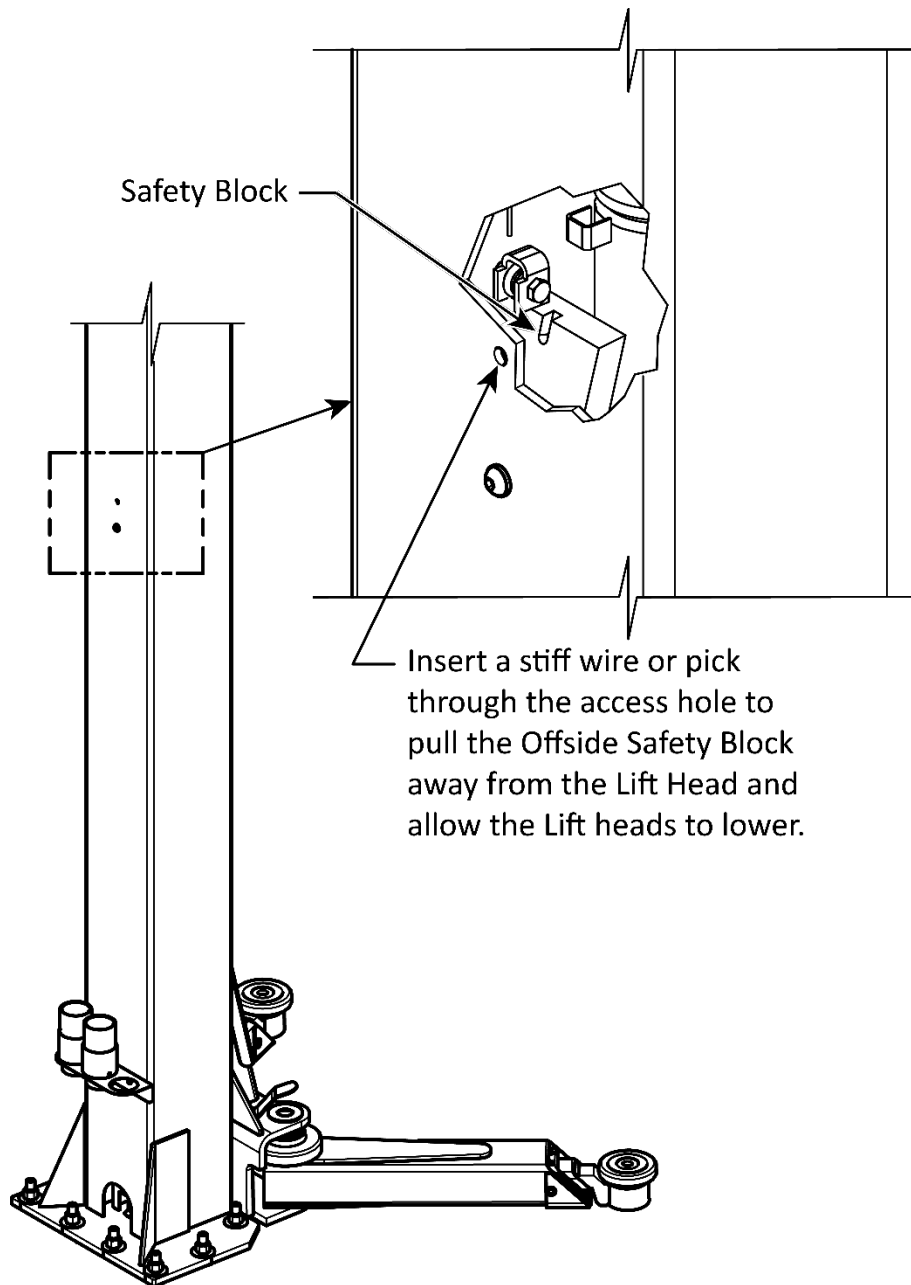


## Broken Safety Cable Procedure

If the Safety Cable breaks, the Powerside Lift head will lower but the Offside Lift Head will not.

### To release the Offside Safety Lock:

1. Raise the Lift Heads off the Safety Locks.
2. Have an assistant reach through the access hole with a stiff wire or pick to pull the Safety Block away from the Lift Head. See figure below.
3. Hold in the Safety Release on the Powerside Lift Post while holding the lower handle on the Power Unit.
4. When the Lift heads are on the ground and the Lift is in a safe condition, remove power from the Lift and replace the Safety Cable.



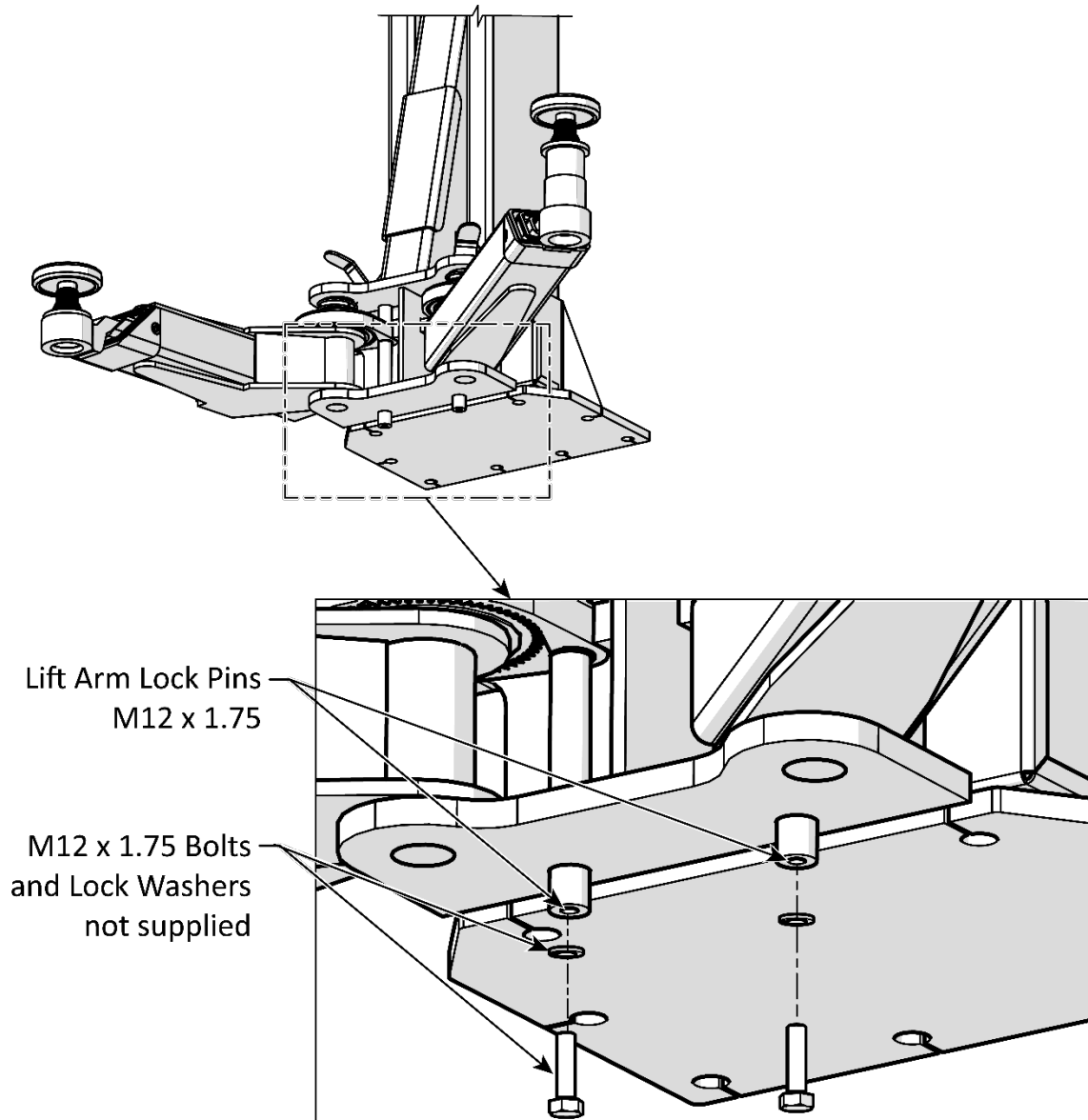
*Reference only – do not scale.*



## Troubleshooting Lift Arm Lock Disengagement

**⚠ WARNING** Avoid excessive Shim heights! A new concrete cutout and steel reinforced pour are recommended to correct out of level conditions in excess of 3°.

Some floors with excessive out of level conditions may require Shim heights that reach or exceed .5 in. / 12.7 mm. When the Shim Height reaches this level, the Lift Arm Lock Pins may not function to disengage the Lift Arms when completely lowered. To correct this condition, the Arm Lock Pins include an M12 x 1.75 internal thread, approximately 12 mm deep. A mating M12 Hex Head Bolt with Lock Washers, or a backing nut (not supplied) may be used to extend the contact point of the Arm Lock Pins. Adjust the Bolt head position to disengage the Lock as required. Refer to the figure below.



---

## Disposing of Used Hydraulic Fluid

Used Hydraulic Fluid cannot be disposed of by dropping it into the trash or dumping into the street. Hydraulic Fluid has toxic ingredients that are harmful to the environment. Either recycle the Hydraulic Fluid or drop it off at a hazardous waste collection facility. Dirty or contaminated fluid must be treated as hazardous waste. Rags and/or granular absorbents that have soaked up Hydraulic Fluid should be treated like hazardous waste and be disposed of at a hazardous waste collection facility.

To find an appropriate facility:

- Local automotive parts stores, auto care facilities, or automobile dealerships may accept fluid for recycling or, in some cases, for disposal. Contact them for more information.
- Cities, counties, and states often support both recycling facilities and hazardous waste collection facilities. Contact them to see if and where they have these programs.

If you are unable to find an appropriate facility, the website [earth911.com](http://earth911.com) has resources that may be of help.

## 10AP Lift Disposal - End of Service Life

Once your Lift has reached the end of its service life it must be disposed of properly. Metal recyclers will be able to advise on methods and costs to remove the Lift and will reuse the materials, diverting them from landfills. The best option is to contact a metal recycling center and discuss the size and weight of the Lift to determine if the facility can deconstruct and recover the usable components and metals.

The Hydraulic Cylinders, Hoses, Fittings, and the Power Unit itself must be disposed of in accordance with current national, state, and local regulations governing the use and disposal of hazardous materials. These components and any used Hydraulic Fluid must not be disposed of by dropping it into the trash or dumping it into the street. The Hydraulic Fluid contains toxic ingredients that are harmful to the environment.

These components and the Hydraulic Fluid are required to be recycled or must be delivered to a hazardous waste collection facility.

If you have large amounts of Hydraulic Fluid, consider contacting a commercial waste disposal company. In all cases, the best approach is to find an appropriate facility and contact them — in advance — to ask them: what kinds of fluids and materials they accept, what kind of containers it must be in, what hours they are open, their location, and any other information specific to their facility.

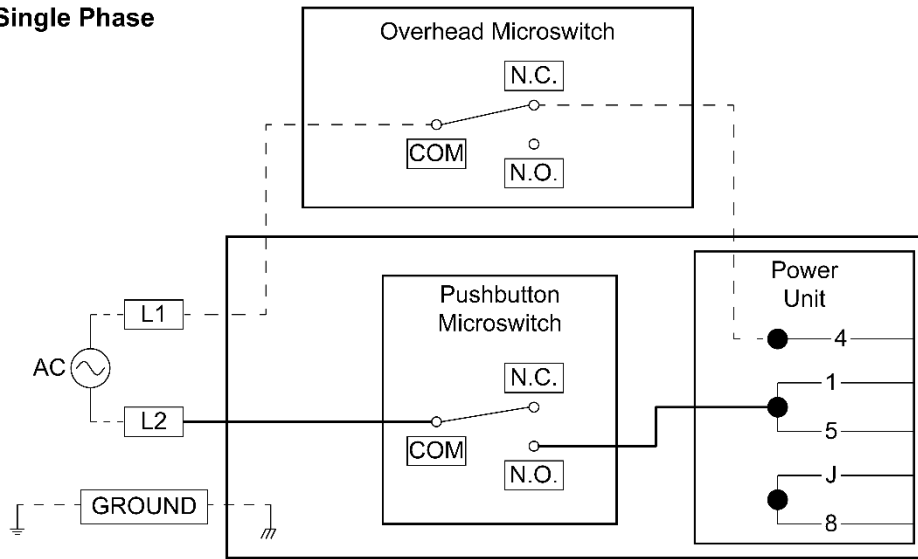
If you are unable to find an appropriate facility, the website [earth911.com](http://earth911.com) has resources that may be of help.

# Wiring Diagrams

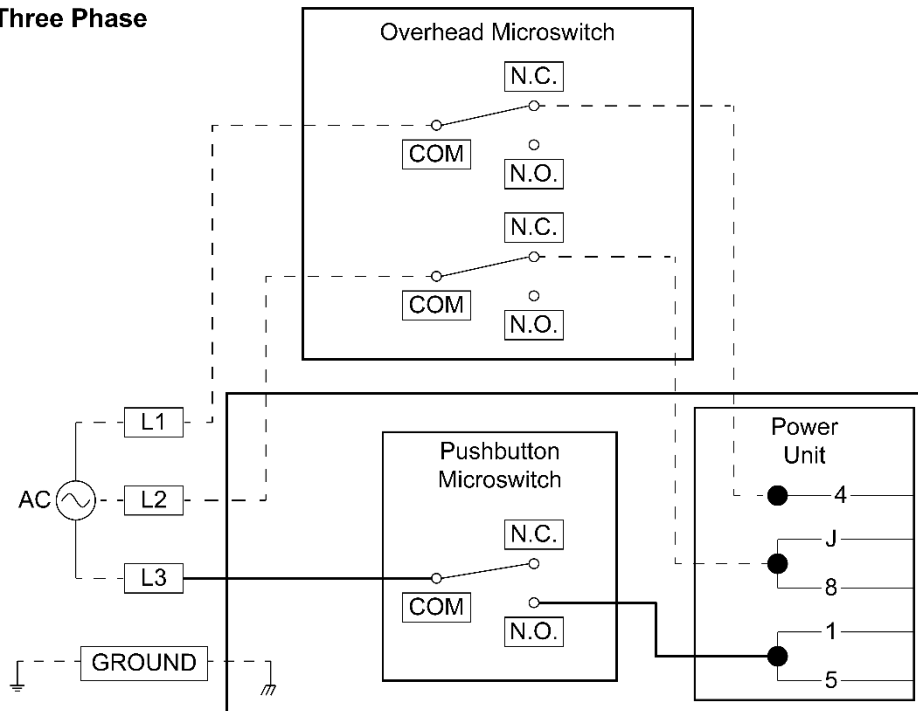
This section includes wiring information for the Microswitch(es).

**⚠ DANGER** All wiring **must** be performed by a licensed, certified Electrician in accordance with all local and national electrical codes. Make sure that main electrical power has been disconnected from the Lift and cannot be re-energized until all procedures are complete. If your organization has Lockout/ Tagout policies, make sure to implement them after connecting the Lift to power.

## Single Phase

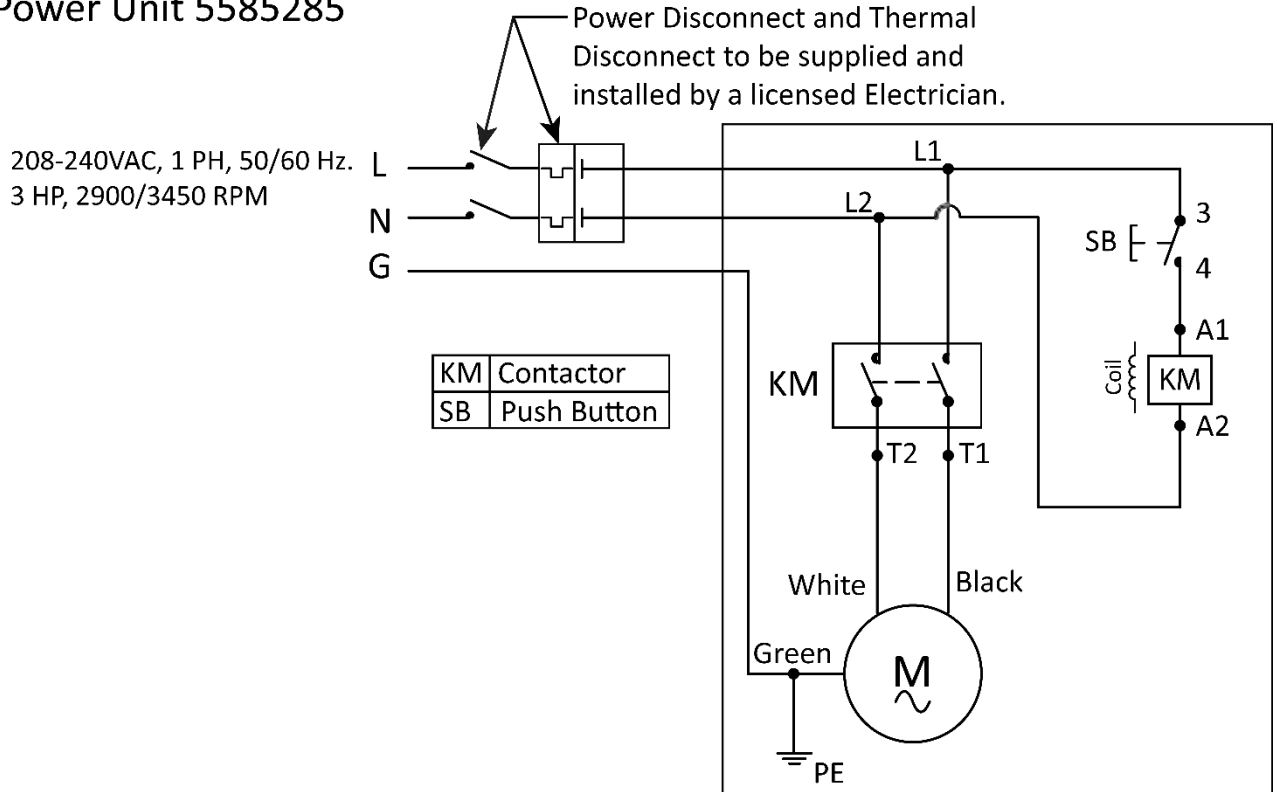


## Three Phase

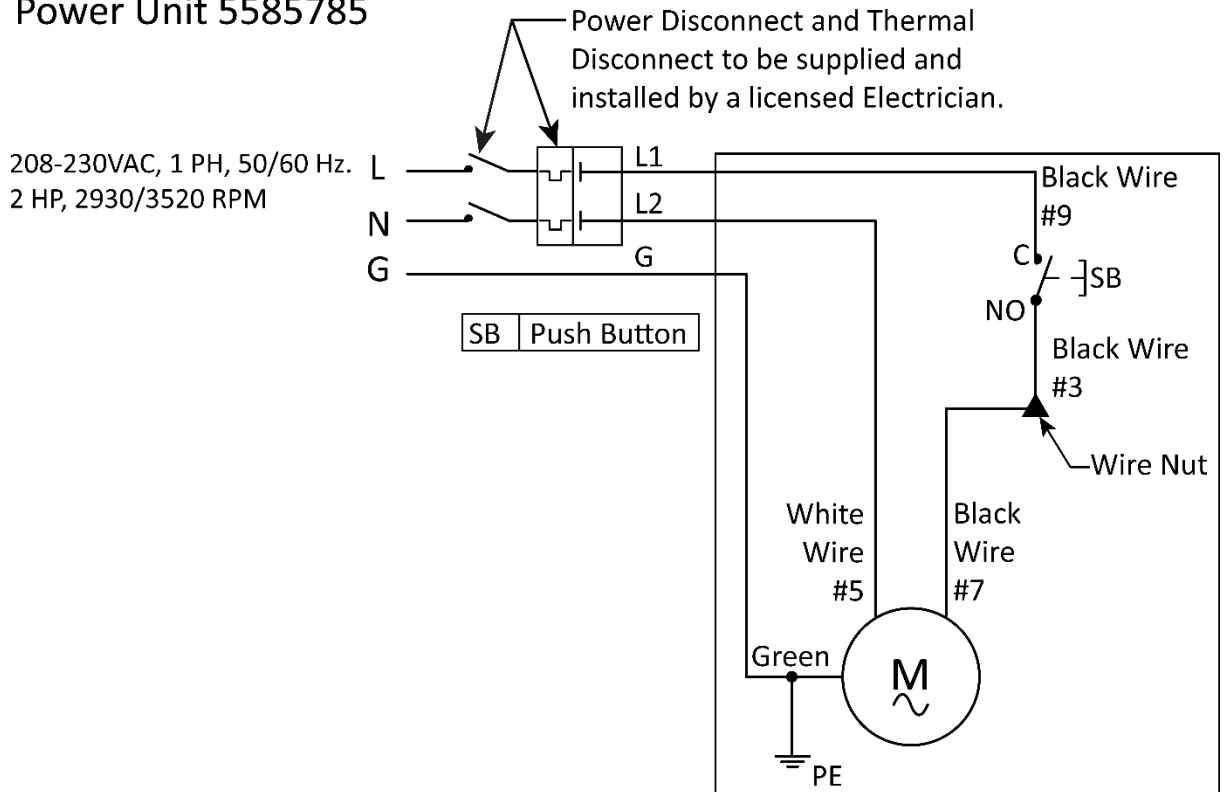


# Power Unit Wiring

## Power Unit 5585285



## Power Unit 5585785





**F**

<p><b>NOTICE</b></p> <p>Read operating and safety manuals before using lift.</p>	<p><b>CAUTION</b></p> <p>Lift to be used by trained operator only.</p>	<p><b>CAUTION</b></p> <p>Authorized personnel only in lift area.</p>	<p><b>WARNING</b></p> <p>Clear area if vehicle is in danger of falling.</p>	<p><b>WARNING</b></p> <p>Position vehicle with center of gravity midway between adapters.</p>
<p><b>NOTICE</b></p> <p>Proper maintenance and inspection is necessary for safe operation.</p>	<p><b>CAUTION</b></p> <p>Use vehicle manufacturer's lift points.</p>	<p><b>CAUTION</b></p> <p>Always use safety stands when removing or installing heavy components.</p>	<p><b>WARNING</b></p> <p>Remain clear of lift when raising or lowering vehicle.</p>	<p><b>WARNING</b></p> <p>Avoid excessive rocking of vehicle while on lift.</p>
<p><b>NOTICE</b></p> <p>Do not operate a damaged lift.</p>	<p><b>CAUTION</b></p> <p>Use height extenders when necessary to ensure good contact.</p>	<p><b>CAUTION</b></p> <p>Auxiliary adapters may reduce load capacity.</p>	<p><b>WARNING</b></p> <p>Do not override self-locking lift controls.</p>	<p><b>WARNING</b></p> <p>Keep feet clear of lift while lowering.</p>

**H**

**NOTICE**

If attachments, accessories, or configuration modifying components used on this lift are located in the load path and affect operation of the lift, affect the lift electrical listing, or affect intended vehicle accommodation; and if they are not certified for use on this lift, then the certification of this lift shall become null and void. Contact the participant for information pertaining to certified attachments, accessories, or configuration modifying components.

www.autolift.org ©2011 by ALI, Inc. ALI / WLSIA01

PN 5905377

**J**

<p><b>TO RAISE LIFT:</b></p> <ol style="list-style-type: none"> <li>1. Press and hold UP button.</li> <li>2. When lift is just PAST desired height, release UP button.</li> <li>3. Hold down Lowering Handle. <b>DO NOT</b> hold down Safety Lock Release Handle.</li> <li>4. Release Lowering Handle.</li> </ol>	<p><b>TO LOWER LIFT:</b></p> <ol style="list-style-type: none"> <li>1. Press and hold UP button for two to three seconds, moving lift off safety locks.</li> <li>2. Hold down Safety Lock Release Handle and Lowering Handle.</li> <li>3. When lift is fully lowered, release both handles.</li> </ol>
---	--

PN 5905414

**I**

**BP BendPak** Santa Paula, CA USA www.bendpak.com

MODEL NUMBER	
DESCRIPTION	
LIFT CAPACITY	DATE CODE
VOLTAGE	SERIAL NUMBER
<input type="checkbox"/> 110-120V, 50-60 Hz, 1 Ph <input type="checkbox"/> 208-240V, 50-60 Hz, 1 Ph <input type="checkbox"/> 380-415V, 50-60 Hz, 3 Ph <input type="checkbox"/> 208-480V, 50-60 Hz, 3 Ph	UPC

**DANGER!** Disconnect Power Before Servicing

MADE IN CHINA WARRANTY VOID IF SEAL PLATE IS REMOVED PN 5905950

PN 5905950

**K**

**CALIFORNIA PROPOSITION 65**

**WARNING**

**WARNING!** This product can expose you to chemicals including styrene and vinyl chloride which are on the list of over 900 chemicals identified by the State of California to cause cancer, birth defects or reproductive harm. ALWAYS use this product in accordance with the manufacturer's instructions. For more information, go to www.p65warnings.ca.gov.

PN 5905775

PN 5905775

PN 5905414

**L**

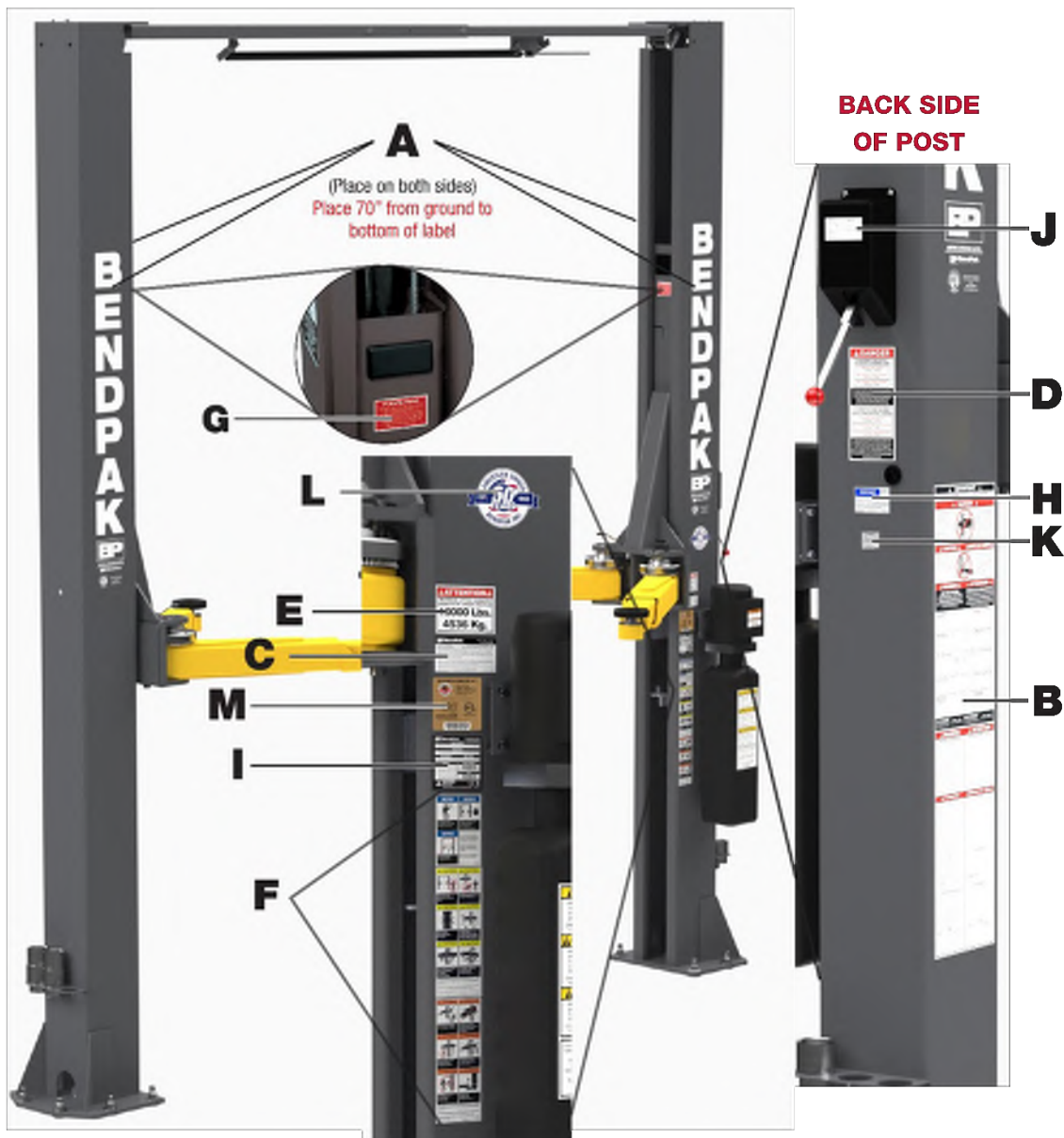


PN 5906044

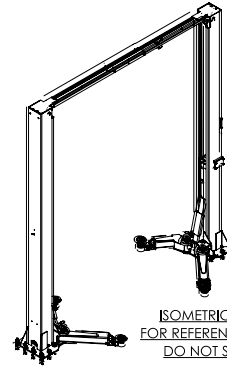
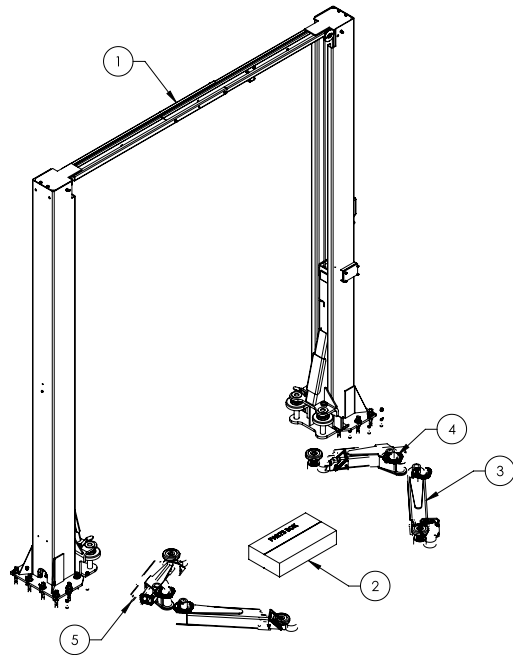
**M**



PN 5905654



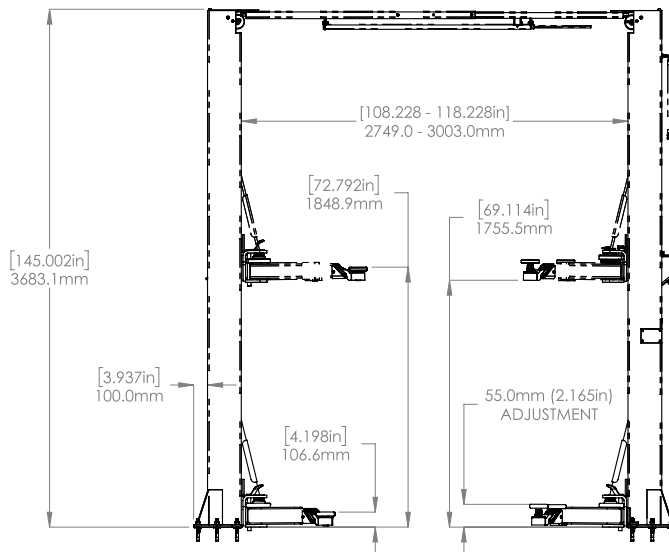
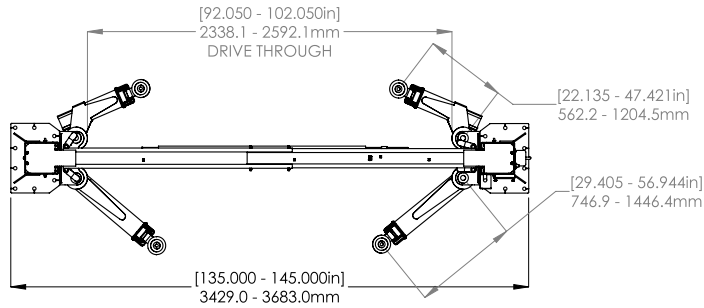
# Parts Drawings



ITEM NO	PART NUMBER	DESCRIPTION	QTY	REV
1	5245246	10AP LIFT SUPERSTRUCTURE	1	L
2	5250343	10AP PARTS BOX	1	F
3	5216216	10AP TRIPLE TELESCOPING ARM ASSEMBLY, LONG	2	B
4	5216217	10AP TRIPLE TELESCOPING ASYMMETRIC ARM ASSEMBLY, LEFT	1	B
5	5216218	10AP TRIPLE TELESCOPING ASYMMETRIC ARM ASSEMBLY, RIGHT	1	B

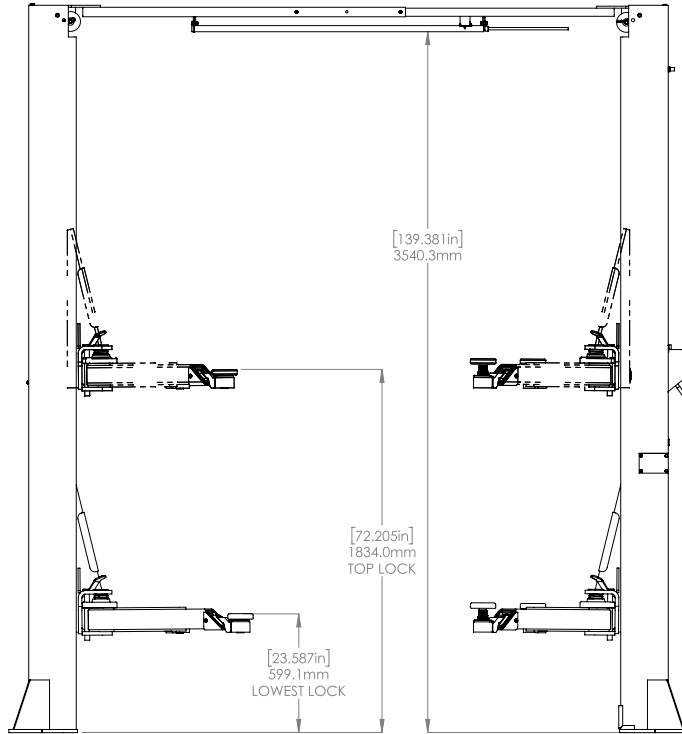
  

DO NOT SCALE DRAWING		NAME	DATE	 1645 LEMONWOOD DR. SANTA PAULA, CA 93060
DRAWN	TM		04/25/2023	
DIMENSIONS ARE IN MM		THIRD ANGLE PROJECTION		TITLE: 10AP PRODUCTION LIFT VER C SIZE DWG. NO. A 5260698 REV B SCALE: 1:30 SHEET 1 OF 3



 1645 LEMONWOOD DR. SANTA PAULA, CA 93060	
TITLE: 10AP PRODUCTION LIFT VER C	
SIZE DWG. NO. A 5260698	REV B
SCALE: 1:32 SHEET 2 OF 3	



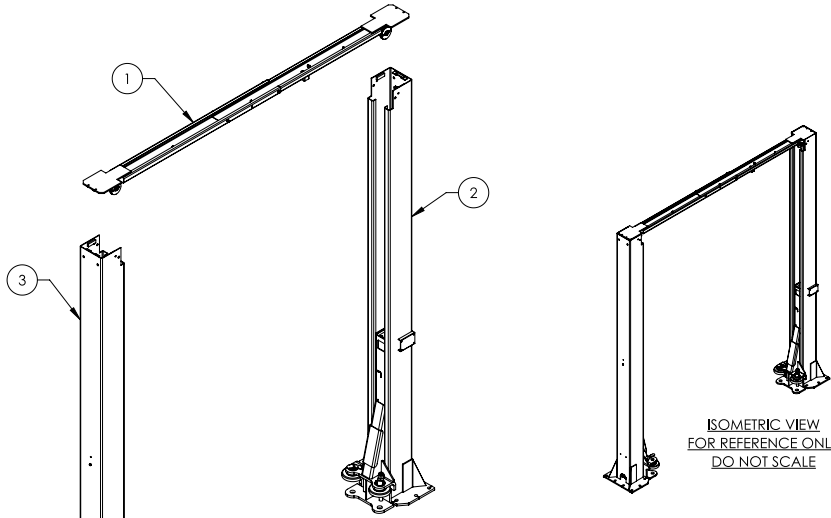


**BendPak**  
 1445 LEMONWOOD DR.  
 SANTA PAULA, CA 93060

TITLE: 10AP PRODUCTION LIFT VER C

SIZE	DWG. NO.	REV
A	5260698	B

SCALE: 1:20 SHEET 3 OF 3



WHERE USED
10AP
10AP-168

ITEM NO	PART NUMBER	DESCRIPTION	QTY	REV
1	5216182	10AP TOP TROUGH ASSEMBLY	1	C
2	5216128	10AP POWER SIDE POST ASSEMBLY	1	K
3	5216129	10AP OFF SIDE POST ASSEMBLY	1	K

DO NOT SCALE DRAWING

DRAWN	CA	04/05/2022
CHECKED	OR	04/28/2023

THIRD ANGLE PROJECTION

**BendPak**  
 1445 LEMONWOOD DR.  
 SANTA PAULA, CA 93060

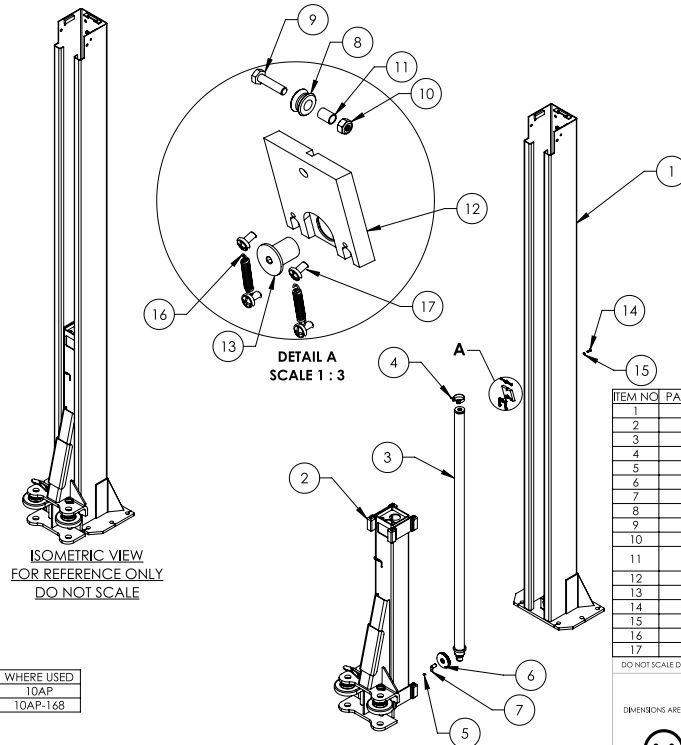
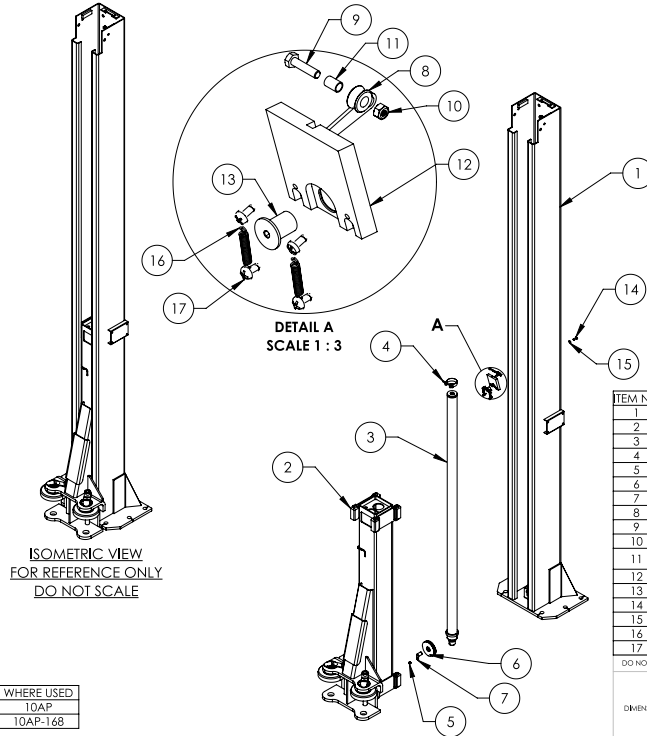
TITLE: 10AP LIFT SUPERSTRUCTURE

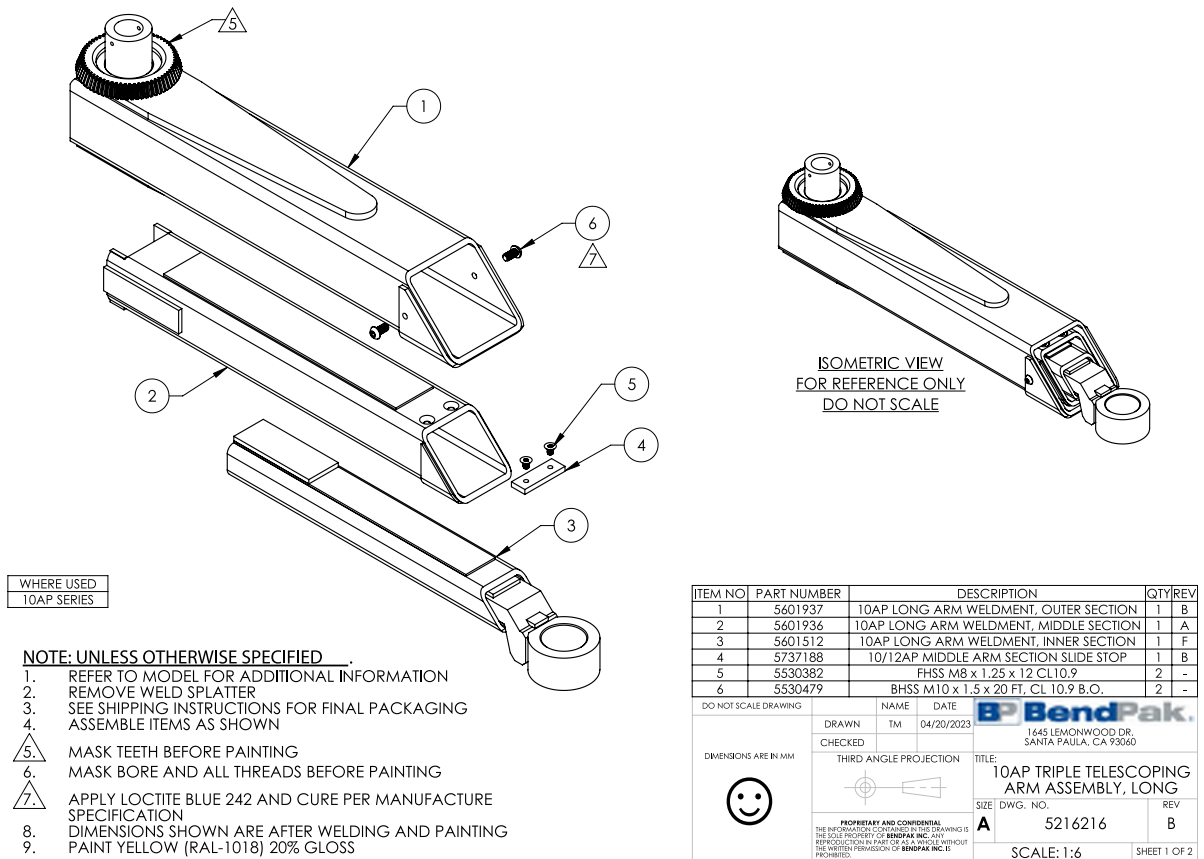
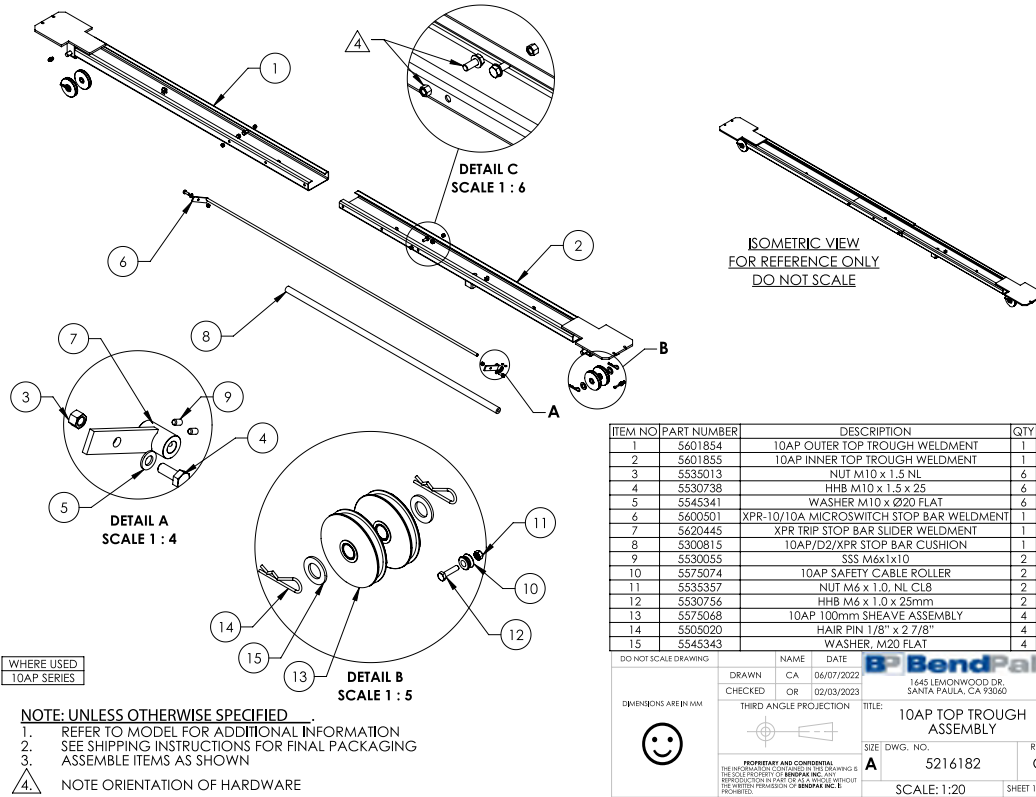
SIZE	DWG. NO.	REV
A	5245246	K

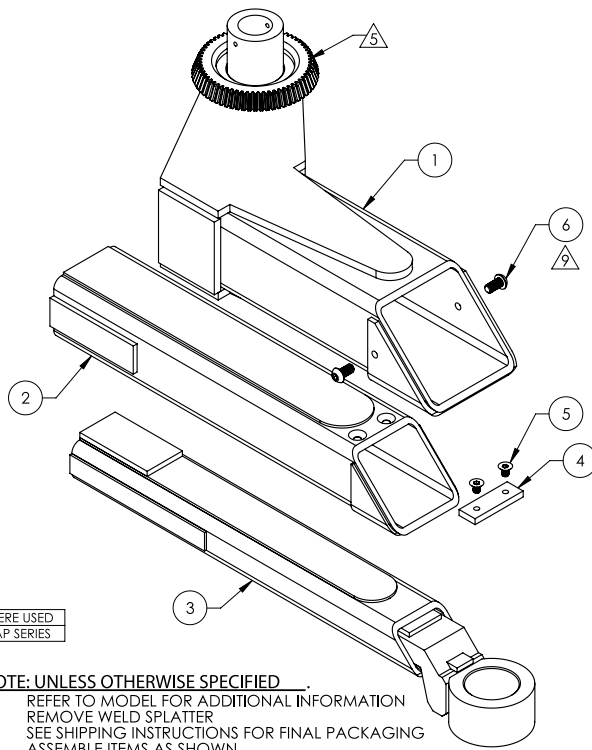
SCALE: 1:30 SHEET 1 OF 1

SMILEY FACE

PROPRIETARY AND CONFIDENTIAL  
 THE INFORMATION CONTAINED IN THIS DRAWING IS THE SOLE PROPERTY OF BENDPAK INC. ANY REPRODUCTION OR TRANSMISSION IN ANY FORM OR BY ANY MEANS WITHOUT THE WRITTEN PERMISSION OF BENDPAK INC. IS PROHIBITED.



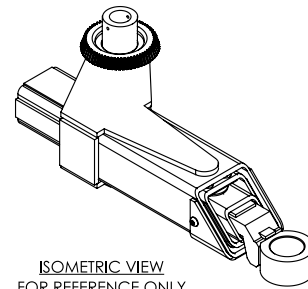




WHERE USED
10AP SERIES

**NOTE: UNLESS OTHERWISE SPECIFIED**

1. REFER TO MODEL FOR ADDITIONAL INFORMATION
2. REMOVE WELD SPLATTER
3. SEE SHIPPING INSTRUCTIONS FOR FINAL PACKAGING
4. ASSEMBLE ITEMS AS SHOWN
5. MASK TEETH BEFORE PAINTING
6. MASK BORE AND ALL THREADS BEFORE PAINTING
7. DIMENSIONS SHOWN ARE AFTER WELDING AND PAINTING
8. PAINT YELLOW (RAL-1018) 20% GLOSS
9. APPLY LOCTITE BLUE 242 AND CURE PER MANUFACTURE SPECIFICATION



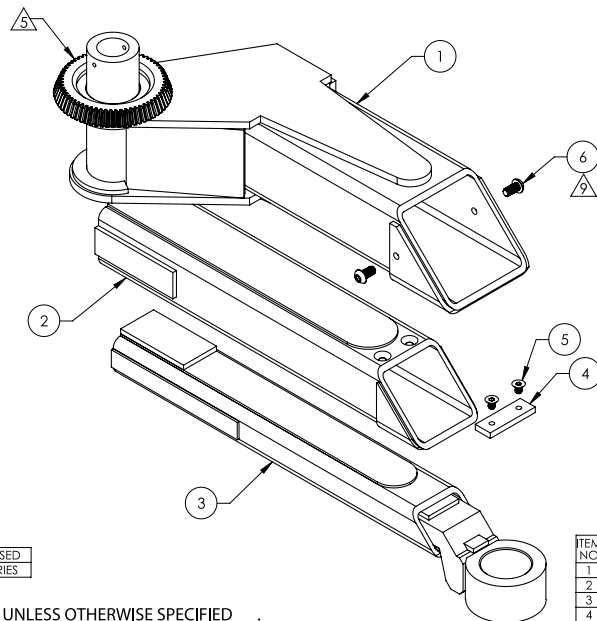
ISOMETRIC VIEW  
FOR REFERENCE ONLY  
DO NOT SCALE

ITEM NO	PART NUMBER	DESCRIPTION	QTY	REV
1	5601938	10AP ASYMMETRIC ARM WELDMENT, OUTER SECTION, LEFT	1	B
2	5601753	10AP ASYMMETRIC ARM WELDMENT, MIDDLE SECTION	1	A
3	5601752	10AP ASYMMETRIC ARM WELDMENT, INNER SECTION	1	B
4	5737188	10/12AP MIDDLE ARM SECTION SLIDE STOP	1	B
5	5530382	FHSS M8 x 1.25 x 12 CL10.9	2	-
6	5530479	BHSS M10 x 1.5 x 20 FT, CL 10.9 B.O.	2	-

DO NOT SCALE DRAWING	NAME	DATE	 1445 LEMONWOOD DR. SANTA PAULA, CA 93060
	DRAWN TM	04/21/2023	
DIMENSIONS ARE IN MM 	CHECKED		TITLE: 10AP TRIPLE TELESCOPING ASYMMETRIC ARM ASSEMBLY, LEFT SIZE DWG. NO. A 5216217 REV B
	THIRD ANGLE PROJECTION		

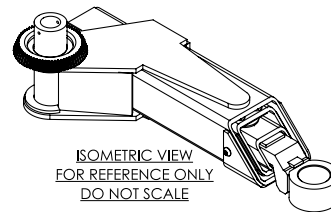
PROPRIETARY AND CONFIDENTIAL  
THE INFORMATION CONTAINED IN THIS DRAWING IS THE SOLE PROPERTY OF BENDPAK INC. ANY REPRODUCTION IN PART OR AS A WHOLE WITHOUT THE WRITTEN PERMISSION OF BENDPAK INC. IS PROHIBITED.



WHERE USED
10AP SERIES

**NOTE: UNLESS OTHERWISE SPECIFIED**

1. REFER TO MODEL FOR ADDITIONAL INFORMATION
2. REMOVE WELD SPLATTER
3. SEE SHIPPING INSTRUCTIONS FOR FINAL PACKAGING
4. ASSEMBLE ITEMS AS SHOWN
5. MASK TEETH BEFORE PAINTING
6. MASK BORE AND ALL THREADS BEFORE PAINTING
7. DIMENSIONS SHOWN ARE AFTER WELDING AND PAINTING
8. PAINT YELLOW (RAL-1018) 20% GLOSS
9. APPLY LOCTITE BLUE 242 AND CURE PER MANUFACTURE SPECIFICATION



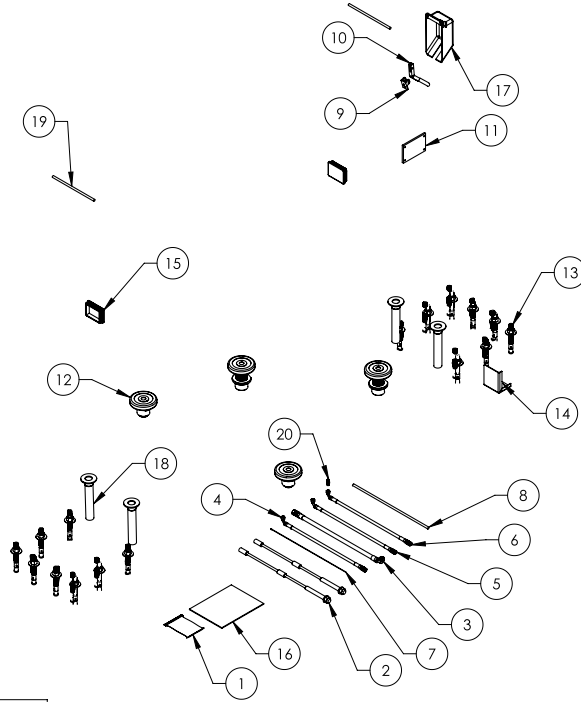
ISOMETRIC VIEW  
FOR REFERENCE ONLY  
DO NOT SCALE

ITEM NO	PART NUMBER	DESCRIPTION	QTY	REV
1	5601939	10AP ASYMMETRIC ARM WELDMENT, OUTER SECTION, RIGHT	1	B
2	5601753	10AP ASYMMETRIC ARM WELDMENT, MIDDLE SECTION	1	A
3	5601752	10AP ASYMMETRIC ARM WELDMENT, INNER SECTION	1	B
4	5737188	10/12AP MIDDLE ARM SECTION SLIDE STOP	1	B
5	5530382	FHSS M8 x 1.25 x 12 CL10.9	2	-
6	5530479	BHSS M10 x 1.5 x 20 FT, CL 10.9 B.O.	2	-

DO NOT SCALE DRAWING	NAME	DATE	 1445 LEMONWOOD DR. SANTA PAULA, CA 93060
	DRAWN TM	04/24/2023	
DIMENSIONS ARE IN MM 	CHECKED		TITLE: 10AP TRIPLE TELESCOPING ASYMMETRIC ARM ASSEMBLY, RIGHT SIZE DWG. NO. A 5216218 REV B
	THIRD ANGLE PROJECTION		

PROPRIETARY AND CONFIDENTIAL  
THE INFORMATION CONTAINED IN THIS DRAWING IS THE SOLE PROPERTY OF BENDPAK INC. ANY REPRODUCTION IN PART OR AS A WHOLE WITHOUT THE WRITTEN PERMISSION OF BENDPAK INC. IS PROHIBITED.



WHERE USED  
IOAP

- NOTE: UNLESS OTHERWISE SPECIFIED**
- SEE SHIPPING INSTRUCTIONS FOR FINAL PACKAGING
  - INSERT PARTS BAG INTO PARTS BOX FOR SHIPMENT
  - HOSES AND CABLES SHOWN REPRESENTATIONAL FORM

ITEM NO	PART NUMBER	DESCRIPTION	QTY	REV
1	5174047	IOAP SERIES PARTS BAG	1	K
2	5595752	CABLE ASSEMBLY Ø10 x 10170mm DBST	2	A
3	5570277	HYDRAULIC HOSE ASSEMBLY Ø10 x 2217mm SB	1	A
4	5570279	HYDRAULIC HOSE ASSEMBLY Ø6.35 x 3276mm SB	1	B
5	5570291	HYDRAULIC HOSE ASSEMBLY Ø6.35 x 6960mm SB	1	C
6	5570174	HYDRAULIC HOSE ASSEMBLY Ø6.35 x 285mm SB	1	B
7	5595793	SAFETY CABLE Ø1.8 x 7773mm	1	A
8	5520116	14-4 SJO UL 62 CABLE 300vac	3538mm	-
9	5700404	10/12AP SAFETY PIVOT HOLDER	1	C
10	5761017	IOAP SAFETY HANDLE	1	E
11	5715003	POWER UNIT VIBRATION DAMPENER	1	B
12	5215704	ROUND ADJUSTABLE LIFT PAD ASSEMBLY	4	H
13	5530337	AB 3/4" x 6.3"	16	-
14	5701698	IOAP FOOT GUARD	1	C
15	5715196	10/12AP, D2, XPR POLYETHYLENE COVER BLOCK 105 x 80	2	D
16	5900265	IOAP INSTALLATION MANUAL	1	-
17	5716072	IOAP POWER SIDE PLASTIC SAFETY COVER	1	A
18	5601505	IOAP ARM LOCK PIN WELDMENT, Ø38	4	C
19	5746167	DOUBLE THREADED ROD M10 x 1.5 x 275	2	B
20	5550095	FTG NPL -04 JIC x -04 JIC	1	-

DO NOT SCALE DRAWING

NAME: CA DATE: 03/28/2022

DRAWN: CA CHECKED: OR 04/28/2023

1645 LEWISWOOD DR. SANTA PAULA, CA 93060

THIRD ANGLE PROJECTION

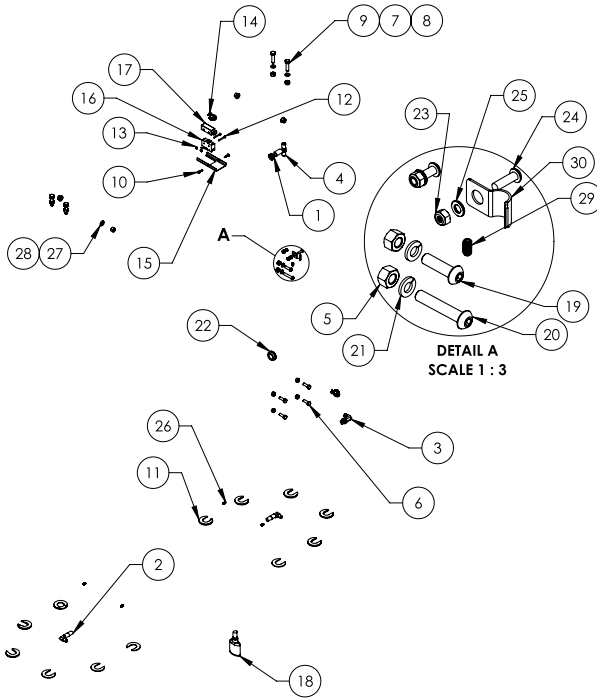
SMILEY FACE

PROPRIETARY AND CONFIDENTIAL THE INFORMATION CONTAINED HEREIN IS THE PROPERTY OF BENDPAK INC. REPRODUCTION BY ANY METHOD IS PROHIBITED WITHOUT THE WRITTEN PERMISSION OF BENDPAK INC.

TITLE: IOAP PARTS BOX

SIZE: A DWG. NO.: 5250343 REV: F

SCALE: 1:20 SHEET 1 OF 1



WHERE USED  
IOAP SERIES

ITEM NO	PART NUMBER	DESCRIPTION	QTY	REV
1	5535022	NUT 9/16"-18 JN	1	-
2	5550113	FTG ELB -04 NPT L x -04 JIC	2	-
3	5550183	FTG ELB -06 JIC -06L ORB	1	-
4	5550003	FTG TEE -04 JIC -04 JIC -06 JIC	1	-
5	5535001	NUT M8 x 1.25 NL	6	-
6	5530010	HNB M8 x 1.25 x 25mm ZPL	4	-
7	5545200	WASHER M10 x Ø18 SL	4	-
8	5535998	NUT M10 x 1.5	4	-
9	5530760	HNB M10 x 1.5 x 38mm	4	-
10	5530799	HSDS M4.2 x 1.41 x 20	2	-
11	5545535	C WASHER SHIM FOR LIFTS	20	-
12	5530115	BHS 6-32 x 1.25	2	-
13	5535190	HN 6-32	2	-
14	5520140	ROMEX CONNECTOR 3/8 #6623	2	-
15	5716634	D2/10AP/XPR MICROSWITCH COVER, PLASTIC	1	B
16	5525150	SPDT MICRO SWITCH;25A@125VAC	1	-
17	5525112	MICRO SWITCH COVER-5PA2	1	-
18	5580012	LIQUID PTFE THREAD SEALANT 50ml	1	-
19	5530412	BHSK M8 x 1.25 x 30 CL10.9	1	-
20	5530413	BHSK M8 x 1.25 x 45 CL10.9	1	-
21	5545202	WASHER M8 x Ø15 SL	2	-
22	5520001	RUBBER GROMMET, 3/4 I.D.	1	-
23	5535357	NUT M6 x 1.0, NL, CL8	2	-
24	5530065	BHSK M6 x 1.0 x 20	2	-
25	5545005	WASHER, M6 x 12mm FLAT	2	-
26	5530423	SSS M6 x 1.0 x 12 CONE	4	-
27	5545341	WASHER M10 x Ø20 FLAT	4	-
28	5535013	NUT M10 x 1.5 NL	4	-
29	5530460	SSS M6 x 1.0 x 12 NL FLAT	1	-
30	5505051	Ø10mm PIPE STRAP	1	A

DO NOT SCALE DRAWING

NAME: TM DATE: 01/14/2020

DRAWN: TM CHECKED: OR 04/28/2023

1645 LEWISWOOD DR. SANTA PAULA, CA 93060

THIRD ANGLE PROJECTION

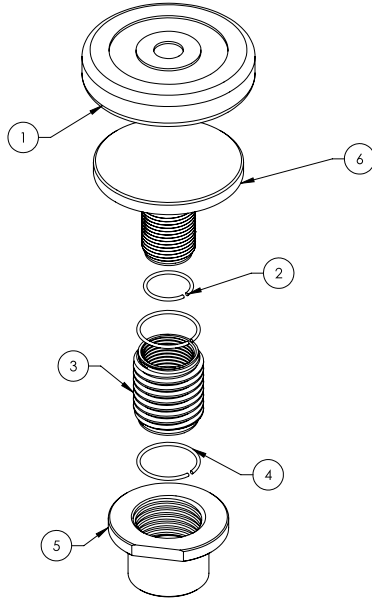
SMILEY FACE

PROPRIETARY AND CONFIDENTIAL THE INFORMATION CONTAINED HEREIN IS THE PROPERTY OF BENDPAK INC. REPRODUCTION BY ANY METHOD IS PROHIBITED WITHOUT THE WRITTEN PERMISSION OF BENDPAK INC.

TITLE: IOAP SERIES PARTS BAG

SIZE: A DWG. NO.: 5174047 REV: K

SCALE: 1:16 SHEET 1 OF 1



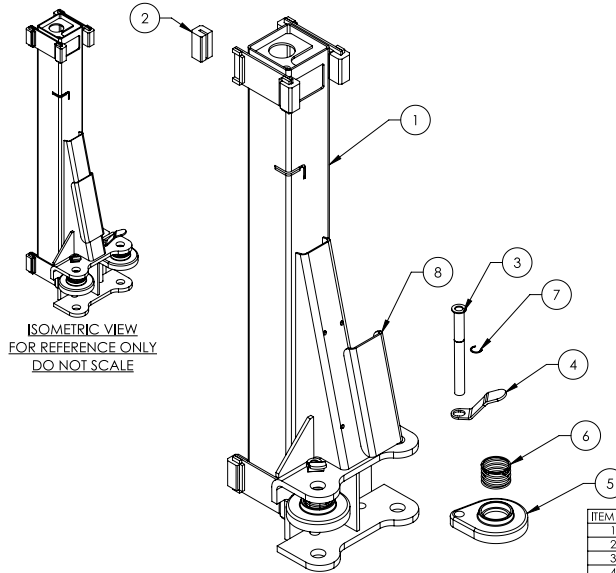
WHERE USED
10AP SERIES
XPR-9 SERIES

- NOTE: UNLESS OTHERWISE SPECIFIED**
- REFER TO MODEL FOR ADDITIONAL INFORMATION
  - SEE SHIPPING INSTRUCTIONS FOR FINAL PACKAGING
  - ASSEMBLE ITEMS AS SHOWN

ITEM NO	PART NUMBER	DESCRIPTION	QTY	REV
1	5715017	ROUND LIFT PAD ADAPTER POLYURETHANE PAD	1	E
2	5540025	S RING Ø35mm	1	A
3	5746692	INNER SCREW	1	C
4	5540026	S RING Ø45mm	2	A
5	5746693	ROUND LIFT PAD ADAPTOR	1	D
6	5601001	ROUND LIFT PAD ADAPTOR WELDMENT	1	D

DO NOT SCALE DRAWING	NAME	DATE	<b>BendPak</b>	
DRAWN	CHY	06/14/2015	1445 LEMONWOOD DR. SANTA PAULA, CA 93060	
CHECKED	CA	06/29/2018		
DIMENSIONS ARE IN MM	THIRD ANGLE PROJECTION	TITLE:	SIZE	REV
☺		ROUND ADJUSTABLE LIFT PAD ASSEMBLY	A	H
		5215704		
			SCALE: 1:3	SHEET 1 OF 1



ISOMETRIC VIEW  
FOR REFERENCE ONLY  
DO NOT SCALE

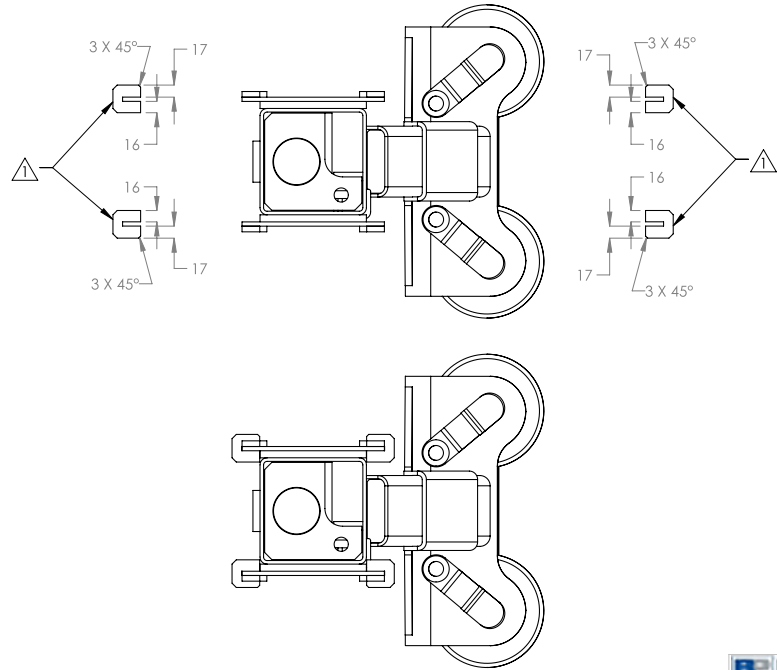
WHERE USED
10AP
10AP-168

- NOTE: UNLESS OTHERWISE SPECIFIED**
- REFER TO MODEL FOR ADDITIONAL INFORMATION
  - SEE SHIPPING INSTRUCTIONS FOR FINAL PACKAGING
  - ASSEMBLE ITEMS AS SHOWN

ITEM NO	PART NUMBER	DESCRIPTION	QTY	REV
1	5601852	10AP LIFT HEAD WELDMENT	1	D
2	5716001	2 POST GUIDE BLOCK	8	H
3	5601509	10AP ARM LOCK GUIDE ROD WELDMENT	2	E
4	5701700	10AP ARM LOCK RELEASE HANDLE	2	C
5	5701701	10AP ARM INTERNAL FULL CIRCLE GEAR STOP	2	C
6	5540044	COMPRESSION SPRING Ø74 x 50mm	2	-
7	5540006	SNAP RING TRUARC 5103-100	2	-
8	5930003	10AP LIFT HEAD GUSSET COVER	1	B

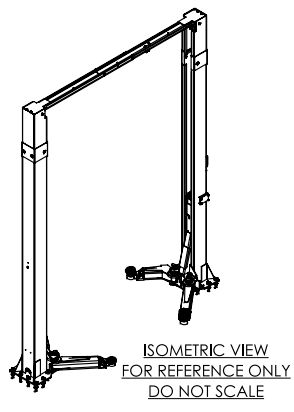
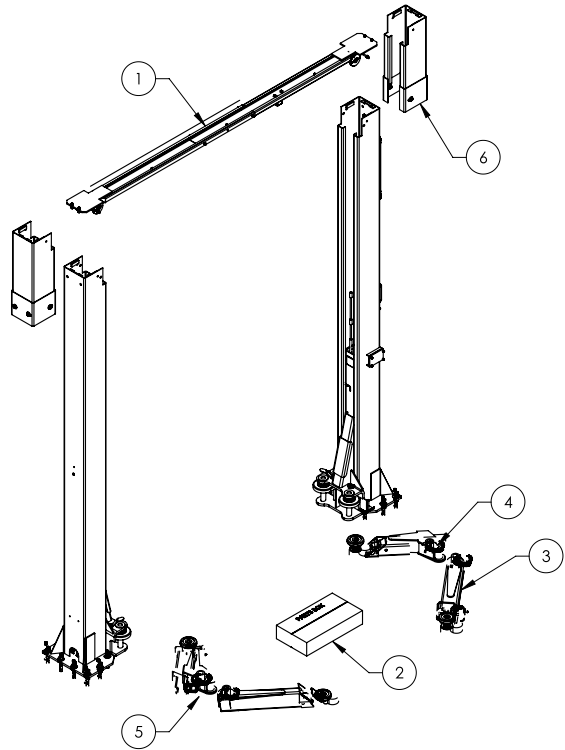
DO NOT SCALE DRAWING	NAME	DATE	<b>BendPak</b>	
DRAWN	CA	06/07/2022	1445 LEMONWOOD DR. SANTA PAULA, CA 93060	
CHECKED	OR	02/03/2023		
DIMENSIONS ARE IN MM	THIRD ANGLE PROJECTION	TITLE:	SIZE	REV
☺		10AP LIFT HEAD ASSEMBLY	A	F
		5216180		
			SCALE: 1:10	SHEET 1 OF 2



TOP VIEW

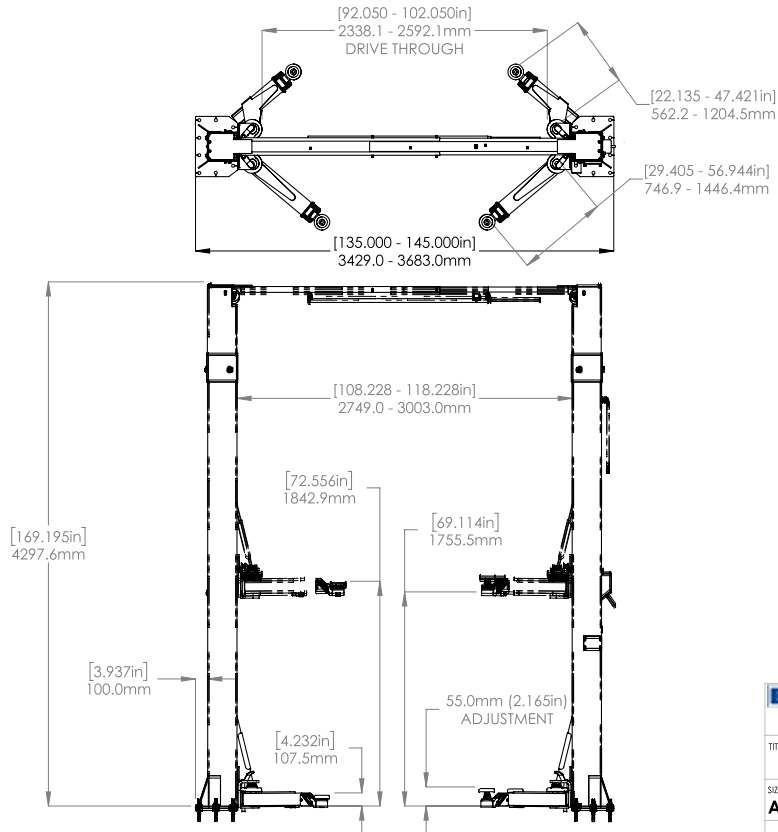
NOTE: UNLESS OTHERWISE SPECIFIED  
 △ NOTE ORIENTATION OF PLASTIC GUIDE BLOCK

1645 LEMONWOOD DR. SANTA PAULA, CA 93060	
TITLE: 10AP LIFT HEAD ASSEMBLY	
SIZE: DWG. NO. <b>A</b> 5216180	REV F
SCALE: 1:10	SHEET 2 OF 2

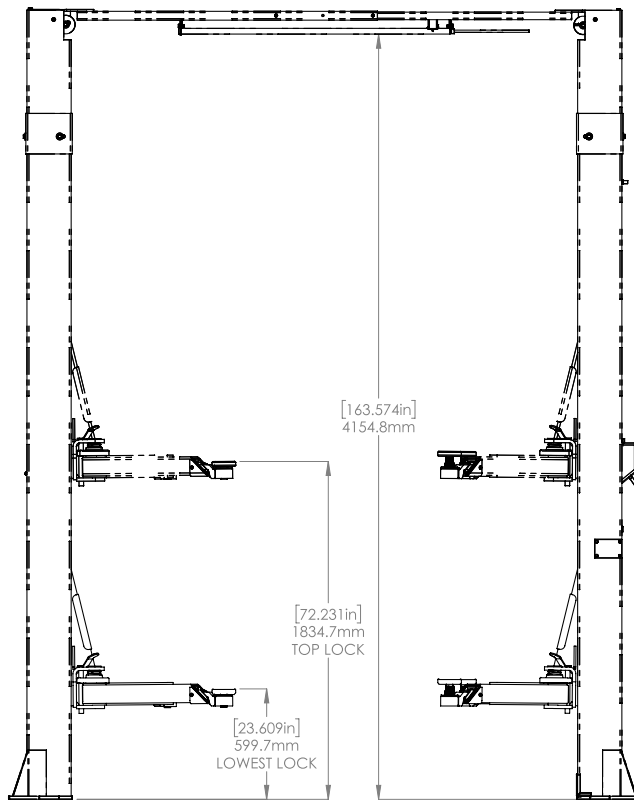


ITEM NO	PART NUMBER	DESCRIPTION	QTY	REV
1	5245246	10AP LIFT SUPERSTRUCTURE	1	L
2	5250344	10AP-168 PARTS BOX	1	F
3	5216216	10AP TRIPLE TELESCOPING ARM ASSEMBLY, LONG	2	B
4	5216217	10AP TRIPLE TELESCOPING ASYMMETRIC ARM ASSEMBLY, LEFT	1	B
5	5216218	10AP TRIPLE TELESCOPING ASYMMETRIC ARM ASSEMBLY, RIGHT	1	B
6	5215971	10AP POST EXTENSION ASSEMBLY	2	C

DO NOT SCALE DRAWING		NAME	DATE		
DRAWN	TM	04/25/2023	1645 LEMONWOOD DR. SANTA PAULA, CA 93060		
CHECKED	THIRD ANGLE PROJECTION		TITLE: 10AP-168 PRODUCTION LIFT VER C		
DIMENSIONS ARE IN MM				SIZE: DWG. NO. <b>A</b> 5260699	REV B
		<small>           PROPRIETARY AND CONFIDENTIAL            THE INFORMATION CONTAINED IN THIS DRAWING IS THE SOLE PROPERTY OF BENDPAK INC. ANY REPRODUCTION IN PART OR AS A WHOLE WITHOUT THE WRITTEN PERMISSION OF BENDPAK INC. IS PROHIBITED.         </small>		SCALE: 1:35	SHEET 1 OF 3

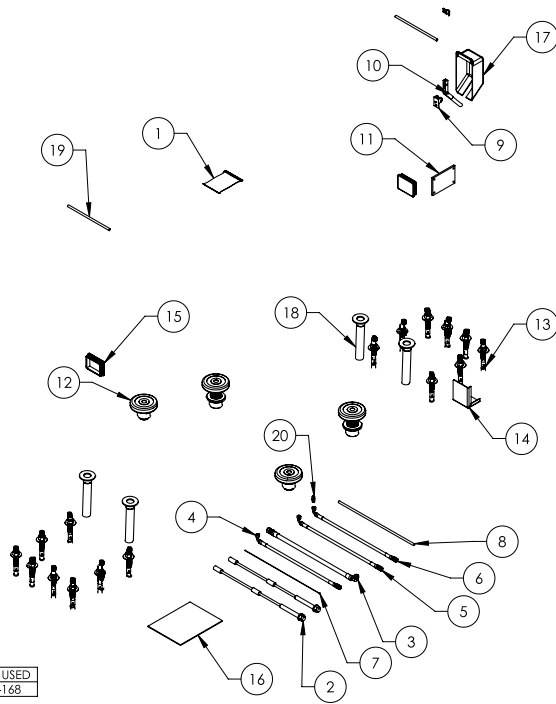


<b>BendPak.</b>	
1445 LEMONWOOD DR. SANTA PAULA, CA 93060	
TITLE: 10AP-168 PRODUCTION LIFT VER C	
SIZE	REV
<b>A</b>	<b>B</b>
DWG. NO. 5260699	
SCALE: 1:35	SHEET 2 OF 3



<b>BendPak.</b>	
1445 LEMONWOOD DR. SANTA PAULA, CA 93060	
TITLE: 10AP-168 PRODUCTION LIFT VER C	
SIZE	REV
<b>A</b>	<b>B</b>
DWG. NO. 5260699	
SCALE: 1:23	SHEET 3 OF 3





WHERE USED  
10AP-168

**NOTE: UNLESS OTHERWISE SPECIFIED**  
 1. SEE SHIPPING INSTRUCTIONS FOR FINAL PACKAGING  
 2. INSERT PARTS BAG INTO PARTS BOX FOR SHIPMENT  
 3. HOSES AND CABLES SHOWN REPRESENTATIONAL FORM

ITEM NO	PART NUMBER	DESCRIPTION	QTY	REV
1	5174047	10AP SERIES PARTS BAG	1	K
2	5595753	CABLE ASSEMBLY Ø10 x 11400mm DBST	2	A
3	5570277	HYDRAULIC HOSE ASSEMBLY Ø10 x 2217mm SB	1	A
4	5570279	HYDRAULIC HOSE ASSEMBLY Ø6.35 x 3276mm SB	1	B
5	5570292	HYDRAULIC HOSE ASSEMBLY Ø6.35 x 8178mm SB	1	C
6	5570174	HYDRAULIC HOSE ASSEMBLY Ø6.35 x 285mm SB	1	B
7	5595831	SAFETY CABLE Ø1.8 x 8865mm	1	A
8	5520116	14-4 SJO UL 62 CABLE 300vac	4178mm	-
9	5700404	10/12AP SAFETY PIVOT HOLDER	1	C
10	5761017	10AP SAFETY HANDLE	1	E
11	5715003	POWER UNIT VIBRATION DAMPENER	1	B
12	5215704	ROUND ADJUSTABLE LIFT PAD ASSEMBLY	4	H
13	5530337	AB 3/4" x 6.3"	16	-
14	5701698	10AP FOOT GUARD	1	C
15	5715196	10/12AP, D2, XPR POLYETHYLENE COVER BLOCK 105 x 80	2	D
16	5900265	10AP INSTALLATION MANUAL	1	-
17	5716072	10AP POWER SIDE PLASTIC SAFETY COVER	1	A
18	5601505	10AP ARM LOCK PIN WELDMENT, Ø38	4	C
19	5746167	DOUBLE THREADED ROD M10 x 1.5 x 275	2	B
20	5550095	FTG NPL -04 JIC x -04 JIC	1	-

DO NOT SCALE DRAWING

NAME	DATE	
DRAWN	CA 03/28/2022	
CHECKED	OR 04/28/2023	1645 LEMONWOOD DR. SANTA PAULA, CA 93060

DIMENSIONS ARE IN MM

THIRD ANGLE PROJECTION

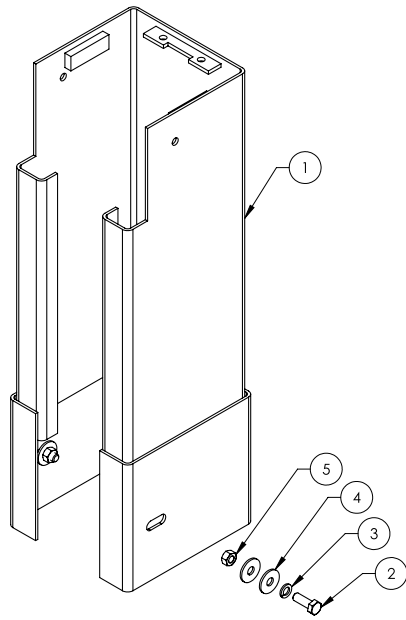
TITLE: 10AP-168 PARTS BOX

SIZE DWG. NO. REV

A 5250344 F

SCALE: 1:20 SHEET 1 OF 1

PROPRIETARY AND CONFIDENTIAL  
 THE INFORMATION CONTAINED IN THIS DRAWING IS THE SOLE PROPERTY OF BENDPAK INC. ANY REPRODUCTION IN WHOLE OR IN PART WITHOUT THE WRITTEN PERMISSION OF BENDPAK INC. IS PROHIBITED.



WHERE USED  
10AP-168  
10APX-181

ISOMETRIC VIEW  
FOR REFERENCE ONLY  
DO NOT SCALE

ITEM NO	PART NUMBER	DESCRIPTION	QTY	REV
1	5601538	10AP POST EXTENSION WELDMENT	1	C
2	5530076	HHB M12 x 1.75 x 35mm	4	-
3	5545201	WASHER, M12 SPRING LOCK	4	-
4	5545027	WASHER M12 x Ø37	8	-
5	5535354	NUT, M12 x1.75	4	-

DO NOT SCALE DRAWING

NAME	DATE	
DRAWN	CA 07/17/2020	
CHECKED	OR 12/08/2021	1645 LEMONWOOD DR. SANTA PAULA, CA 93060

DIMENSIONS ARE IN MM

THIRD ANGLE PROJECTION

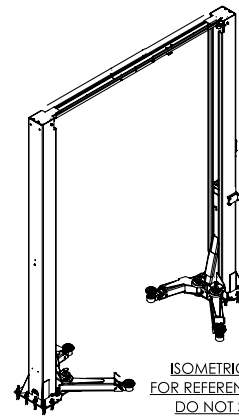
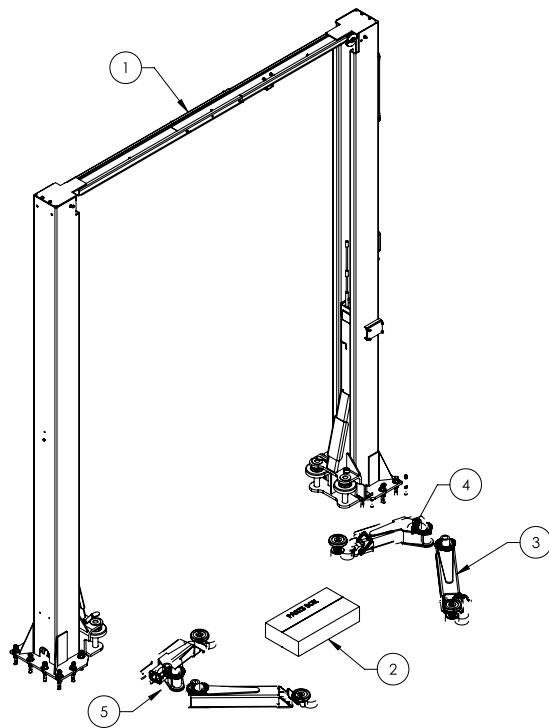
TITLE: 10AP POST EXTENSION ASSEMBLY

SIZE DWG. NO. REV

A 5215971 C

SCALE: 1:6 SHEET 1 OF 1

PROPRIETARY AND CONFIDENTIAL  
 THE INFORMATION CONTAINED IN THIS DRAWING IS THE SOLE PROPERTY OF BENDPAK INC. ANY REPRODUCTION IN WHOLE OR IN PART WITHOUT THE WRITTEN PERMISSION OF BENDPAK INC. IS PROHIBITED.



ITEM NO	PART NUMBER	DESCRIPTION	QTY	REV
1	5245249	10APX LIFT SUPERSTRUCTURE	1	L
2	5250346	10APX PARTS BOX	1	F
3	5216216	10AP TRIPLE TELESCOPING ARM ASSEMBLY, LONG	2	B
4	5216217	10AP TRIPLE TELESCOPING ASYMMETRIC ARM ASSEMBLY, LEFT	1	B
5	5216218	10AP TRIPLE TELESCOPING ASYMMETRIC ARM ASSEMBLY, RIGHT	1	B

DO NOT SCALE DRAWING

NAME: **BendPak** DATE: 04/25/2023

DRAWN: TM

CHECKED:

THIRD ANGLE PROJECTION

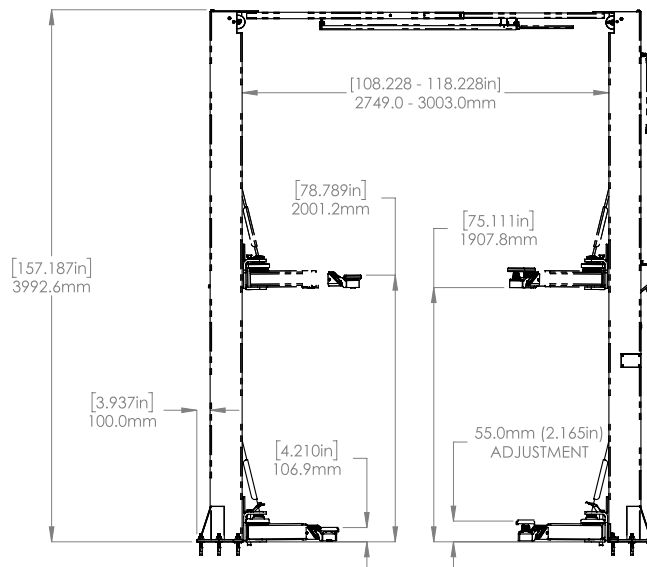
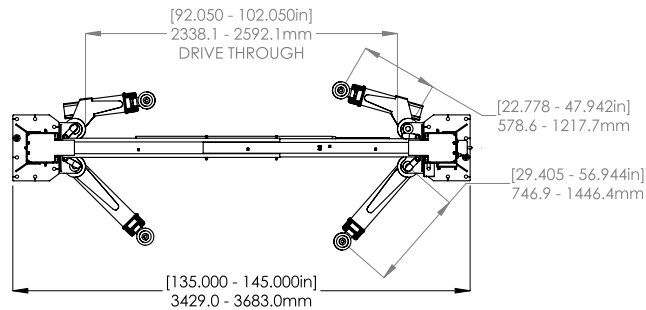
1645 LEMONWOOD DR.  
SANTA PAULA, CA 93060

TITLE: 10APX PRODUCTION LIFT VER C

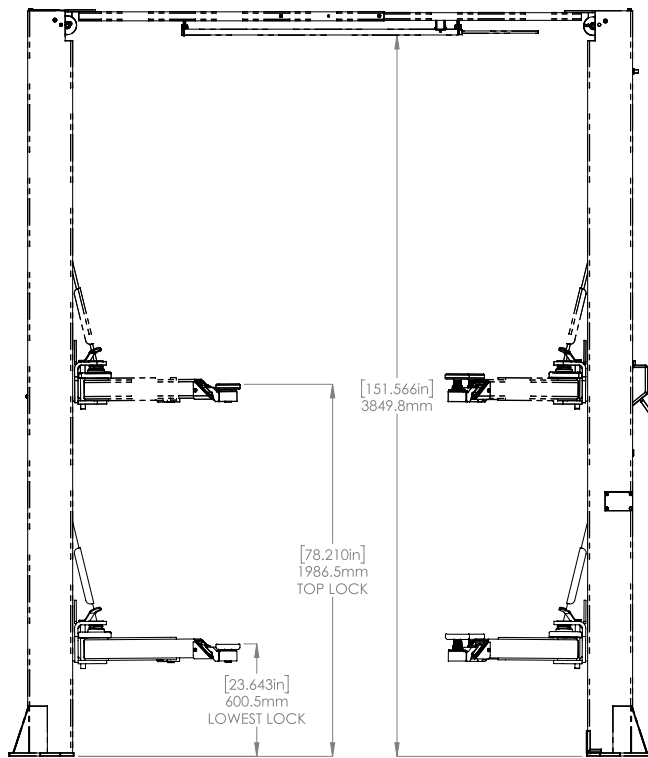
SIZE: DWG. NO. **A** 5260700 REV **B**

SCALE: 1:30 SHEET 1 OF 3

PROPERTY AND CONFIDENTIAL  
THE INFORMATION CONTAINED IN THIS DRAWING IS THE SOLE PROPERTY OF BENDPAK INC. AND IS NOT TO BE REPRODUCED OR TRANSMITTED IN ANY FORM OR BY ANY MEANS WITHOUT THE WRITTEN PERMISSION OF BENDPAK INC. IS PROHIBITED.



BendPak	
1645 LEMONWOOD DR. SANTA PAULA, CA 93060	
TITLE: 10APX PRODUCTION LIFT VER C	
SIZE: DWG. NO. <b>A</b> 5260700	REV <b>B</b>
SCALE: 1:34 SHEET 2 OF 3	

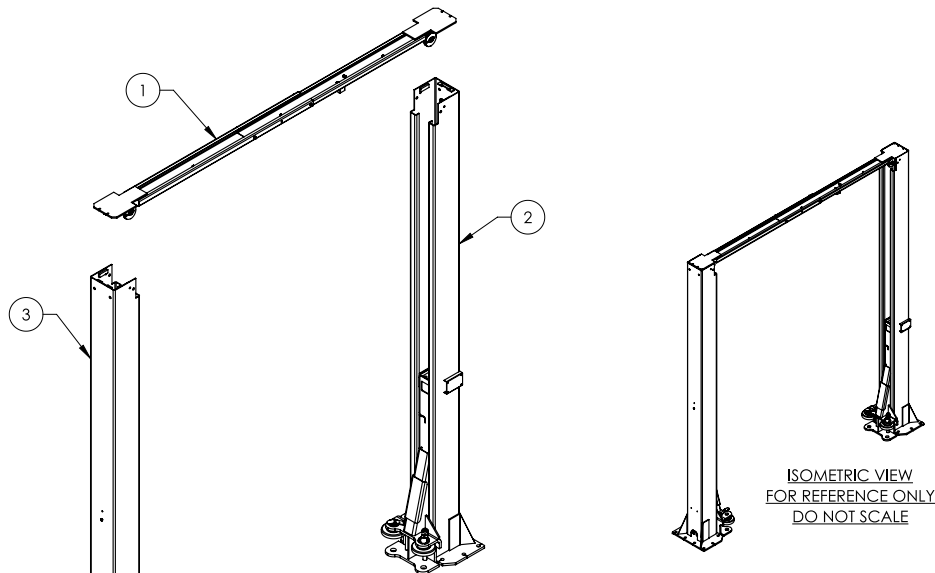


**BP BendPak.**  
1645 LEMONWOOD DR.  
SANTA PAULA, CA 93060

TITLE: 10APX PRODUCTION  
LIFT VER C

SIZE	DWG. NO.	REV
A	5260700	B

SCALE: 1:22 SHEET 3 OF 3



WHERE USED
10AP
10AP-168

ITEM NO	PART NUMBER	DESCRIPTION	QTY	REV
1	5216182	10AP TOP TROUGH ASSEMBLY	1	C
2	5216128	10AP POWER SIDE POST ASSEMBLY	1	K
3	5216129	10AP OFF SIDE POST ASSEMBLY	1	K

DO NOT SCALE DRAWING

DRAWN	CA	DATE	04/05/2022
CHECKED	OR	DATE	04/28/2023

THIRD ANGLE PROJECTION

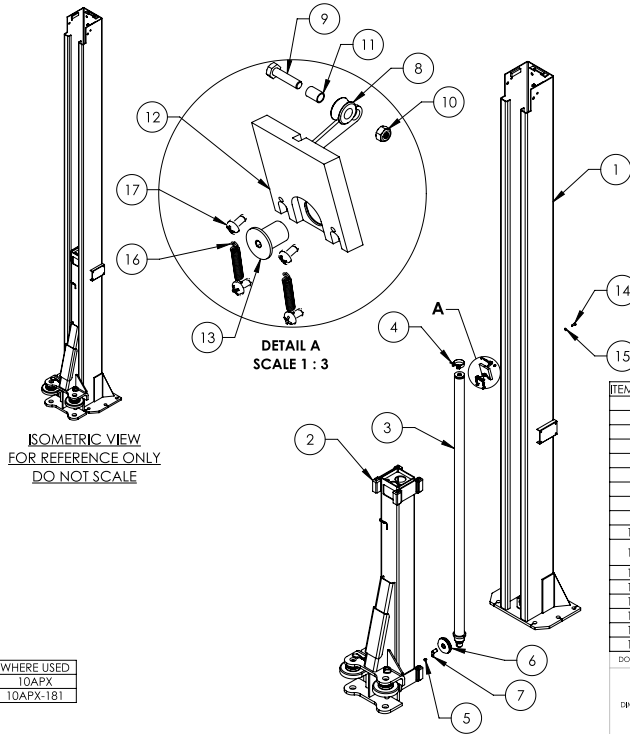
PROPRIETARY AND CONFIDENTIAL  
THE INFORMATION CONTAINED IN THIS DRAWING IS  
THE SOLE PROPERTY OF BENDPAK INC. ANY  
REPRODUCTION IN PART OR AS A WHOLE WITHOUT  
THE WRITTEN PERMISSION OF BENDPAK INC. IS  
PROHIBITED.

**BP BendPak.**  
1645 LEMONWOOD DR.  
SANTA PAULA, CA 93060

TITLE: 10AP LIFT  
SUPERSTRUCTURE

SIZE	DWG. NO.	REV
A	5245246	K

SCALE: 1:30 SHEET 1 OF 1



**NOTE: UNLESS OTHERWISE SPECIFIED**

1. REFER TO MODEL FOR ADDITIONAL INFORMATION
2. SEE SHIPPING INSTRUCTIONS FOR FINAL PACKAGING
3. ASSEMBLE ITEMS AS SHOWN

ITEM NO.	PART NUMBER	DESCRIPTION	QTY	REV
1	5601812	10APX POWER SIDE POST WELDMENT	1	D
2	5216181	10APX LIFT HEAD ASSEMBLY	1	F
3	5502725	CYLINDER ASSEMBLY Ø2.0 x 75 - SLOW	1	D
4	5701242	CYLINDER CLAMP ASSY	1	-
5	5530366	FHSS M6 x 1.0 x 8	1	-
6	5575068	10AP 100mm SHEAVE ASSEMBLY	1	B
7	5620143	D2-10, 10AP CABLE SHEAVE PIN WELDMENT	1	C
8	5575074	10/12AP SAFETY CABLE ROLLER	1	A
9	5530756	HHB M6 x 1.0 x 25mm	1	-
10	5535357	NUT M6 x 1.0, NL CL8	1	-
11	5565350	10/12AP/D2/GP/PCL/XPR/ PL-7000 SAFETY SHEAVE SPACER	1	C
12	5601516	10AP POWER SIDE SAFETY WELDMENT	1	E
13	5746494	10/12AP SAFETY PIVOT PIN	1	C
14	5530414	BHSC M8 x 1.25 x 25 CL10.9	1	-
15	5545202	WASHER M8 x Ø15 SL	1	-
16	5540047	EXTENSION SPRING Ø6.35 x 38mm	2	-
17	5530045	BHPS M5 x 0.8 x 10	4	-

DO NOT SCALE DRAWING

NAME: \_\_\_\_\_ DATE: \_\_\_\_\_

DRAWN: CA 04/05/2022  
CHECKED: OR 04/28/2023

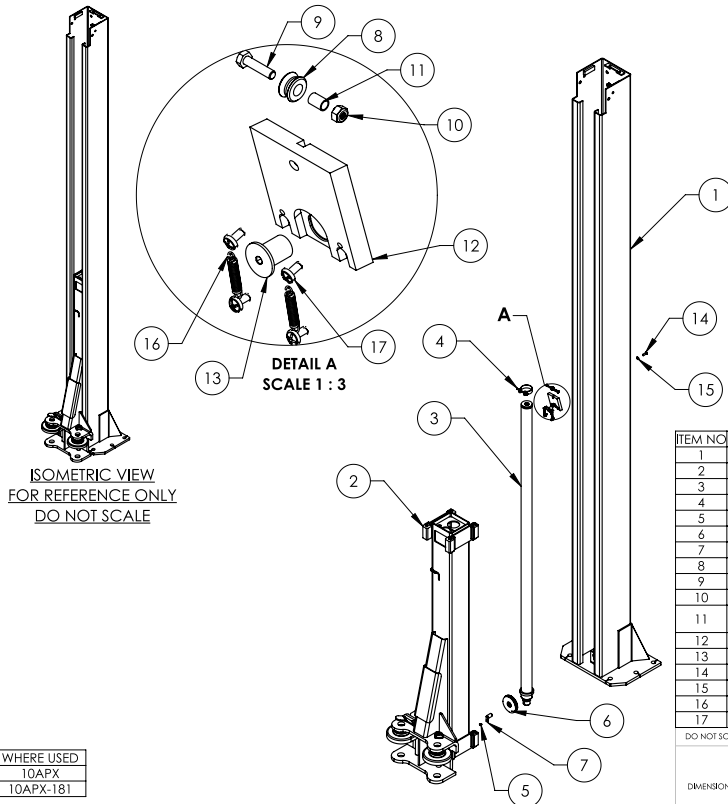
1645 LEMONWOOD DR.  
SANTA PAULA, CA 93060

TITLE: 10APX POWER SIDE POST ASSEMBLY

SIZE: DWG. NO. 5216130 REV K

SCALE: 1:25 SHEET 1 OF 1

PROPRIETARY AND CONFIDENTIAL  
THE INFORMATION CONTAINED HEREIN IS THE PROPERTY OF BENDPAK INC. ANY REPRODUCTION OR TRANSMISSION OF THIS INFORMATION WITHOUT THE WRITTEN PERMISSION OF BENDPAK INC. IS PROHIBITED.



**NOTE: UNLESS OTHERWISE SPECIFIED**

1. REFER TO MODEL FOR ADDITIONAL INFORMATION
2. SEE SHIPPING INSTRUCTIONS FOR FINAL PACKAGING
3. ASSEMBLE ITEMS AS SHOWN

ITEM NO.	PART NUMBER	DESCRIPTION	QTY	REV
1	5601851	10APX OFF SIDE POST WELDMENT	1	B
2	5216181	10APX LIFT HEAD ASSEMBLY	1	F
3	5502725	CYLINDER ASSEMBLY Ø2.0 x 75 - SLOW	1	D
4	5701242	CYLINDER CLAMP ASSY	1	-
5	5530366	FHSS M6 x 1.0 x 8	1	-
6	5575068	10AP 100mm SHEAVE ASSEMBLY	1	B
7	5620143	D2-10, 10AP CABLE SHEAVE PIN WELDMENT	1	C
8	5575074	10/12AP SAFETY CABLE ROLLER	1	A
9	5530756	HHB M6 x 1.0 x 25mm	1	-
10	5535357	NUT M6 x 1.0, NL CL8	1	-
11	5565350	10/12AP/D2/GP/PCL/XPR/ PL-7000 SAFETY SHEAVE SPACER	1	C
12	5737177	10AP OFF SIDE SAFETY BLOCK	1	F
13	5746494	10/12AP SAFETY PIVOT PIN	1	C
14	5530414	BHSC M8 x 1.25 x 25 CL10.9	1	-
15	5545202	WASHER M8 x Ø15 SL	1	-
16	5540047	EXTENSION SPRING Ø6.35 x 38mm	2	-
17	5530045	BHPS M5 x 0.8 x 10	4	-

DO NOT SCALE DRAWING

NAME: \_\_\_\_\_ DATE: \_\_\_\_\_

DRAWN: CA 04/05/2022  
CHECKED: OR 04/28/2023

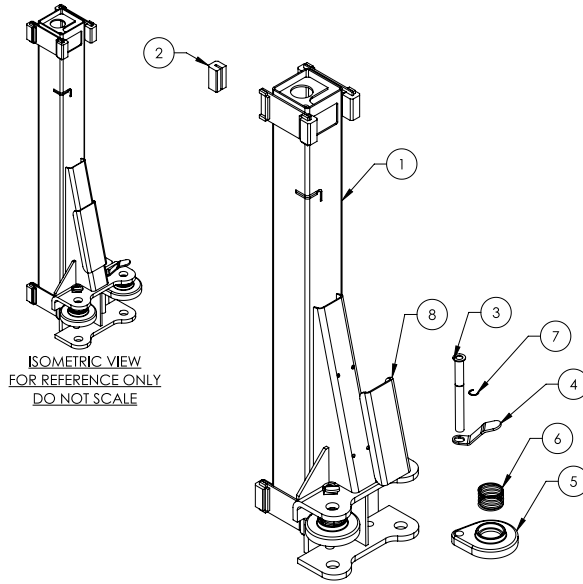
1645 LEMONWOOD DR.  
SANTA PAULA, CA 93060

TITLE: 10APX OFF SIDE POST ASSEMBLY

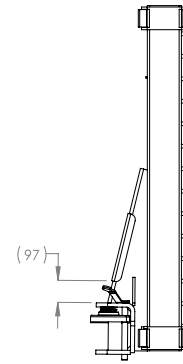
SIZE: DWG. NO. 5216131 REV K

SCALE: 1:25 SHEET 1 OF 1

PROPRIETARY AND CONFIDENTIAL  
THE INFORMATION CONTAINED HEREIN IS THE PROPERTY OF BENDPAK INC. ANY REPRODUCTION OR TRANSMISSION OF THIS INFORMATION WITHOUT THE WRITTEN PERMISSION OF BENDPAK INC. IS PROHIBITED.



ISOMETRIC VIEW  
FOR REFERENCE ONLY  
DO NOT SCALE



ITEM NO	PART NUMBER	DESCRIPTION	QTY	REV
1	5601853	10APX LIFT HEAD WELDMENT	1	D
2	5716001	2 POST GUIDE BLOCK	8	H
3	5601509	10AP ARM LOCK GUIDE ROD WELDMENT	2	E
4	5701700	10AP ARM LOCK RELEASE HANDLE	2	C
5	5701701	10AP ARM INTERNAL FULL CIRCLE GEAR STOP	2	C
6	5540044	COMPRESSION SPRING Ø74 x 50mm	2	-
7	5540006	SNAP RING TRUARC 5103-100	2	-
8	5930003	10AP LIFT HEAD GUSSET COVER	1	B

WHERE USED
10APX
10APX-181

- NOTE: UNLESS OTHERWISE SPECIFIED
- REFER TO MODEL FOR ADDITIONAL INFORMATION
  - SEE SHIPPING INSTRUCTIONS FOR FINAL PACKAGING
  - ASSEMBLE ITEMS AS SHOWN

DO NOT SCALE DRAWING

NAME: DATE: **BendPak**

DRAWN: CA 06/07/2022  
CHECKED: OR 02/03/2023  
1645 LEMONWOOD DR.  
SANTA PAULA, CA 95060

THIRD ANGLE PROJECTION

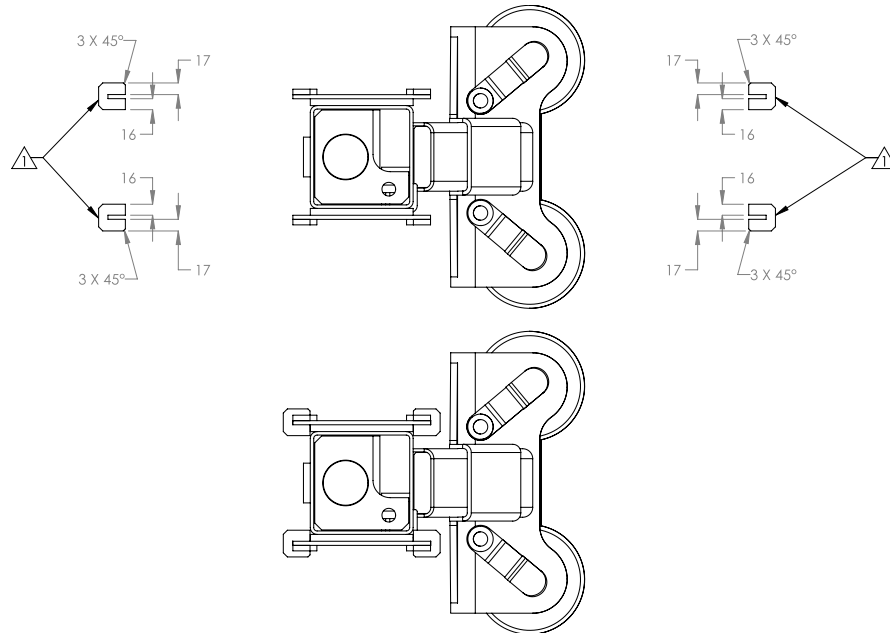
TITLE: 10APX LIFT HEAD ASSEMBLY

SIZE: DWG. NO. REV

**A** 5216181 F

SCALE: 1:12 SHEET 1 OF 2

PROPRIETARY AND CONFIDENTIAL  
THE INFORMATION CONTAINED HEREIN IS THE SOLE PROPERTY OF BENDPAK INC. ANY REPRODUCTION IN WHOLE OR IN PART WITHOUT THE WRITTEN PERMISSION OF BENDPAK INC. IS PROHIBITED.



TOP VIEW

- NOTE: UNLESS OTHERWISE SPECIFIED
- NOTE ORIENTATION OF PLASTIC GUIDE BLOCK

**BendPak**

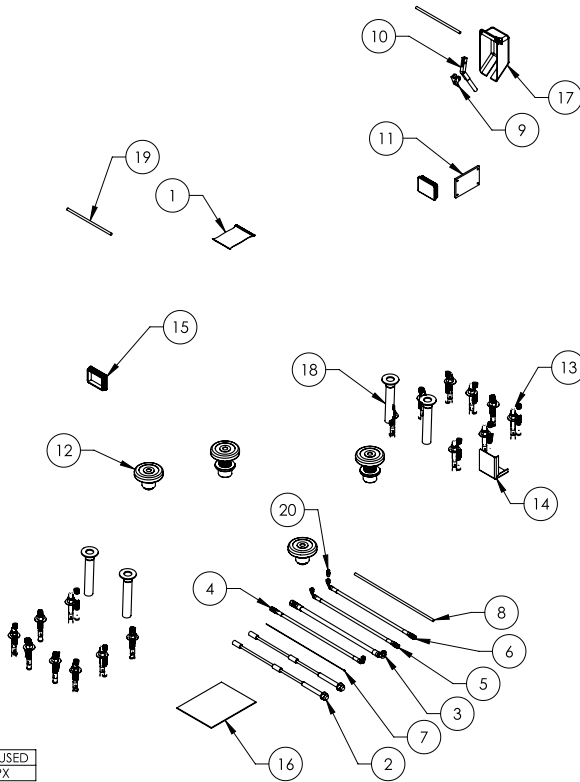
1645 LEMONWOOD DR.  
SANTA PAULA, CA 95060

TITLE: 10APX LIFT HEAD ASSEMBLY

SIZE: DWG. NO. REV

**A** 5216181 F

SCALE: 1:10 SHEET 2 OF 2



WHERE USED  
10APX

- NOTE: UNLESS OTHERWISE SPECIFIED**
1. SEE SHIPPING INSTRUCTIONS FOR FINAL PACKAGING
  2. INSERT PARTS BAG INTO PARTS BOX FOR SHIPMENT
  3. HOSES AND CABLES SHOWN REPRESENTATIONAL FORM

ITEM NO	PART NUMBER	DESCRIPTION	QTY	REV
1	5174047	10AP SERIES PARTS BAG	1	K
2	5595754	CABLE ASSEMBLY Ø10 x 10790mm DBST	2	A
3	5570278	HYDRAULIC HOSE ASSEMBLY Ø10 x 2522mm SB	1	A
4	5570223	HOSE ASSEMBLY Ø6.4 x 3588mm SB	1	B
5	5570293	HYDRAULIC HOSE ASSEMBLY Ø6.35 x 7264mm SB	1	C
6	5570174	HYDRAULIC HOSE ASSEMBLY Ø6.35 x 285mm SB	1	B
7	5595832	SAFETY CABLE Ø1.8 x 8103mm	1	A
8	5520116	14-4 SJO UL 62 CABLE 300vac	3843mm	-
9	5700404	10/12AP SAFETY PIVOT HOLDER	1	C
10	5761017	10AP SAFETY HANDLE	1	E
11	5715003	POWER UNIT VIBRATION DAMPENER	1	B
12	5215704	ROUND ADJUSTABLE LIFT PAD ASSEMBLY	4	H
13	5530337	AB 3/4" x 6.3"	16	-
14	5701698	10AP FOOT GUARD	1	C
15	5715196	10/12AP, D2, XPR POLYETHYLENE COVER BLOCK 105 x 80	2	D
16	5900265	10AP INSTALLATION MANUAL	1	-
17	5716072	10AP POWER SIDE PLASTIC SAFETY COVER	1	A
18	5601505	10AP ARM LOCK PIN WELDMENT, Ø38	4	C
19	5746167	DOUBLE THREADED ROD M10 x 1.5 x 275	2	B
20	5550095	FIG NPL-04 JIC x -04 JIC	1	-

DO NOT SCALE DRAWING

NAME: CA DATE: 03/29/2022

DRAWN: CA CHECKED: OR DATE: 04/28/2023

THIRD ANGLE PROJECTION

SMILEY FACE

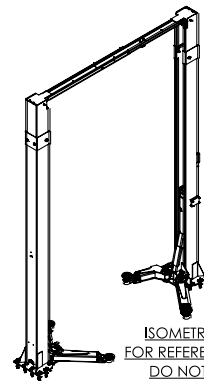
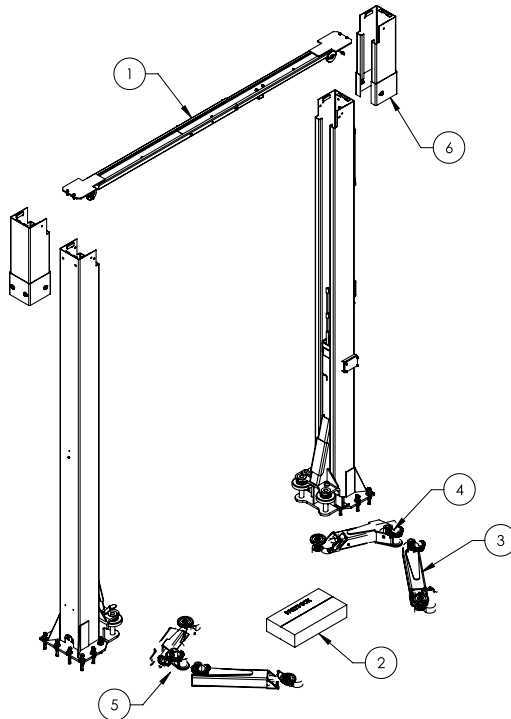
PROPRIETARY AND CONFIDENTIAL THE BENDPAK BRAND IS A TRADEMARK OF BENDPAK INC. ANY REPRODUCTION OF THIS DRAWING WITHOUT THE WRITTEN PERMISSION OF BENDPAK INC. IS PROHIBITED.

1645 LEMONWOOD DR. SANTA PAULA, CA 93060

TITLE: 10APX PARTS BOX

SIZE DWG. NO. 5250346 REV F

SCALE: 1:20 SHEET 1 OF 1



ITEM NO	PART NUMBER	DESCRIPTION	QTY	REV
1	5245249	10APX LIFT SUPERSTRUCTURE	1	L
2	5250347	10APX-181 PARTS BOX	1	F
3	5216216	10AP TRIPLE TELESCOPING ARM ASSEMBLY, LONG	2	B
4	5216217	10AP TRIPLE TELESCOPING ASYMMETRIC ARM ASSEMBLY, LEFT	1	B
5	5216218	10AP TRIPLE TELESCOPING ASYMMETRIC ARM ASSEMBLY, RIGHT	1	B
6	5215971	10AP POST EXTENSION ASSEMBLY	2	C

DO NOT SCALE DRAWING

NAME: TM DATE: 04/25/2023

DRAWN: TM CHECKED: OR DATE: 04/25/2023

THIRD ANGLE PROJECTION

SMILEY FACE

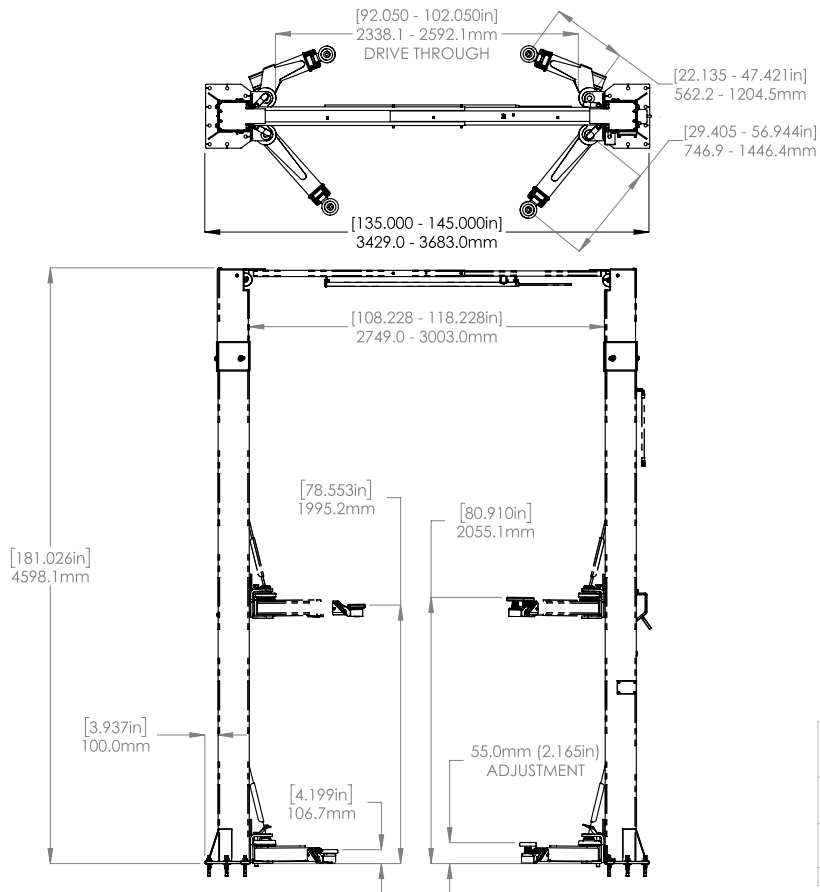
PROPRIETARY AND CONFIDENTIAL THE BENDPAK BRAND IS A TRADEMARK OF BENDPAK INC. ANY REPRODUCTION OF THIS DRAWING WITHOUT THE WRITTEN PERMISSION OF BENDPAK INC. IS PROHIBITED.

1645 LEMONWOOD DR. SANTA PAULA, CA 93060

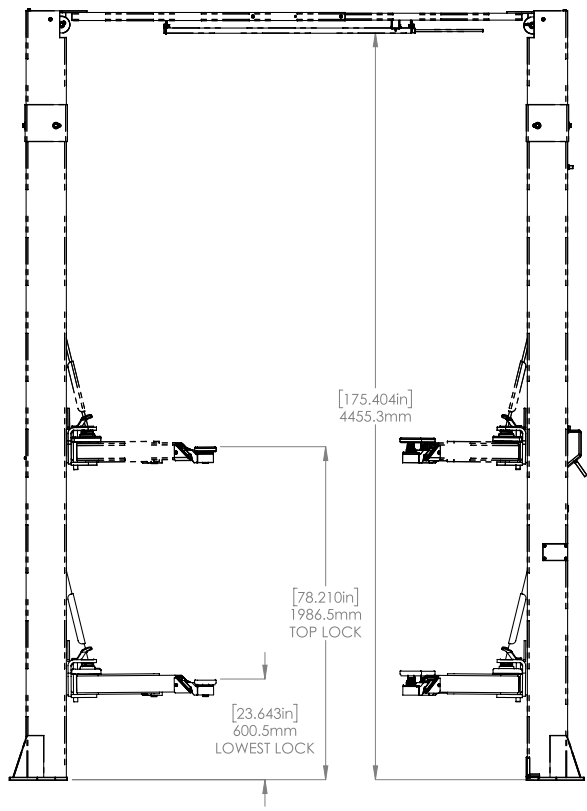
TITLE: 10APX-181 PRODUCTION LIFT VER C

SIZE DWG. NO. 5260701 REV B

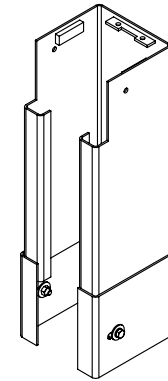
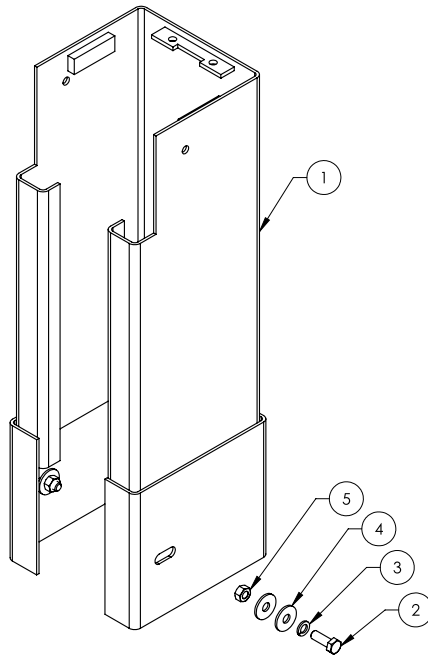
SCALE: 1:35 SHEET 1 OF 3



<b>BendPak.</b>	
1645 LEMONWOOD DR. SANTA PAULA, CA 93060	
TITLE: 10APX-181 PRODUCTION LIFT VER C	
SIZE: DWG. NO.	REV
<b>A</b> 5260701	<b>B</b>
SCALE: 1:35	SHEET 2 OF 3



<b>BendPak.</b>	
1645 LEMONWOOD DR. SANTA PAULA, CA 93060	
TITLE: 10APX-181 PRODUCTION LIFT VER C	
SIZE: DWG. NO.	REV
<b>A</b> 5260701	<b>B</b>
SCALE: 1:23	SHEET 3 OF 3



ISOMETRIC VIEW  
FOR REFERENCE ONLY  
DO NOT SCALE

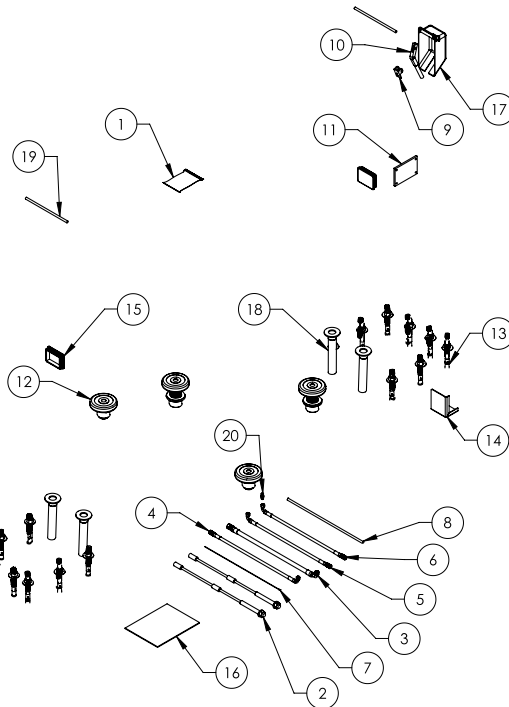
WHERE USED
10AP-168
10APX-181

- NOTE: UNLESS OTHERWISE SPECIFIED**
- REFER TO MODEL FOR ADDITIONAL INFORMATION
  - SEE SHIPPING INSTRUCTIONS FOR FINAL PACKAGING

ITEM NO	PART NUMBER	DESCRIPTION	QTY	REV
1	5601538	10AP POST EXTENSION WELDMENT	1	C
2	5530076	HHB M12 x 1.75 x 35mm	4	-
3	5545201	WASHER, M12 SPRING LOCK	4	-
4	5545027	WASHER M12 x Ø37	8	-
5	5535354	NUT, M12 x1.75	4	-

DO NOT SCALE DRAWING		NAME	DATE	<b>BendPak.</b>
DRAWN	CA	07/17/2020	1645 LEMONWOOD DR. SANTA PAULITA, CA 93060	
CHECKED	OR	12/08/2021		
DIMENSIONS ARE IN MM		THIRD ANGLE PROJECTION		TITLE: 10AP POST EXTENSION ASSEMBLY
☺		⊕		SIZE: DWG. NO. 5215971
		<small>PROPRIETARY AND CONFIDENTIAL THE INFORMATION CONTAINED IN THIS DRAWING IS THE SOLE PROPERTY OF BENDPAK INC. ANY REPRODUCTION OR PARTIAL OR COMPLETE REPRODUCTION IN ANY FORM WITHOUT THE WRITTEN PERMISSION OF BENDPAK INC. IS PROHIBITED.</small>		REV C
		SCALE: 1:6		SHEET 1 OF 1



WHERE USED
10APX-181

- NOTE: UNLESS OTHERWISE SPECIFIED**
- SEE SHIPPING INSTRUCTIONS FOR FINAL PACKAGING
  - INSERT PARTS BAG INTO PARTS BOX FOR SHIPMENT
  - HOSES AND CABLES SHOWN REPRESENTATIONAL FORM

ITEM NO	PART NUMBER	DESCRIPTION	QTY	REV
1	5174047	10AP SERIES PARTS BAG	1	K
2	5595755	CABLE ASSEMBLY Ø10 x 12005mm DBST	2	A
3	5570278	HYDRAULIC HOSE ASSEMBLY Ø10 x 2522mm SB	1	A
4	5570023	HOSE ASSEMBLY Ø6.4 x 3588mm SB	1	B
5	5570095	HYDRAULIC HOSE ASSEMBLY Ø6.35 x 8472 SB	1	B
6	5570174	HYDRAULIC HOSE ASSEMBLY Ø6.35 x 285mm SB	1	B
7	5595833	SAFETY CABLE Ø1.8 x 9322mm	1	A
8	5520116	14-4 SJO UL 62 CABLE 300vac	4453mm	-
9	5700404	10/12AP SAFETY PIVOT HOLDER	1	C
10	5761017	10AP SAFETY HANDLE	1	E
11	5715003	POWER UNIT VIBRATION DAMPENER	1	B
12	5215704	ROUND ADJUSTABLE LIFT PAD ASSEMBLY	4	H
13	5530337	AB 3/4" x 6.3"	16	-
14	5701698	10AP FOOT GUARD	1	C
15	5715196	10/12AP, D2, XPR POLYETHYLENE COVER BLOCK 105 x 80	2	D
16	5900265	10AP INSTALLATION MANUAL	1	-
17	5716072	10AP POWER SIDE PLASTIC SAFETY COVER	1	A
18	5601505	10AP ARM LOCK PIN WELDMENT, Ø38	4	C
19	5746167	DOUBLE THREADED ROD M10 x 1.5 x 275	2	B
20	5550095	FTG NPL-04 JIC x-04 JIC	1	-

DO NOT SCALE DRAWING		NAME	DATE	<b>BendPak.</b>
DRAWN	CA	03/30/2022	1645 LEMONWOOD DR. SANTA PAULITA, CA 93060	
CHECKED	OR	04/28/2023		
DIMENSIONS ARE IN MM		THIRD ANGLE PROJECTION		TITLE: 10APX-181 PARTS BOX
☺		⊕		SIZE: DWG. NO. 5250347
		<small>PROPRIETARY AND CONFIDENTIAL THE INFORMATION CONTAINED IN THIS DRAWING IS THE SOLE PROPERTY OF BENDPAK INC. ANY REPRODUCTION OR PARTIAL OR COMPLETE REPRODUCTION IN ANY FORM WITHOUT THE WRITTEN PERMISSION OF BENDPAK INC. IS PROHIBITED.</small>		REV F
		SCALE: 1:20		SHEET 1 OF 1



# Automotive Lift Institute (ALI) Store

You probably checked the [ALI's Directory of Certified Lifts](http://www.autolift.org/ali-directory-of-certified-lifts/) (www.autolift.org/ali-directory-of-certified-lifts/) before making your most recent Lift purchase, but did you know the **ALI Store** (www.autolift.org/ali-store/) offers a wide variety of professional, easy-to-use, and reasonably priced training and safety materials that will make your garage a safer place to work?

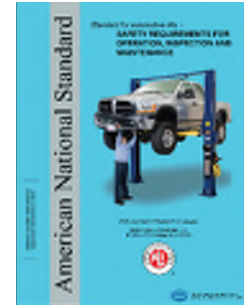
The ALI Store is your trusted source for workplace safety!



**Lifting It Right Online Certificate Course.** Make *sure* you and your people are lifting vehicles the right way.



**ALI Lift Inspector Certification Program Registration.** Become a ALI Certified Lift Inspector.



**ANSI/ALI ALOIM Standard for Automotive Lifts.** Safety Requirements for Operation, Inspection, and Maintenance.



**ANSI/ALI ALIS Standard.** Safety Requirements for Installation and Service.



**Guide to Identifying Vehicle Lifting Points for Frame-Engaging Lifts.** Don't eyeball your lifting points, *know* where they are.



**Lift Operator Safety Materials.** Five safety documents in a single package.



**Lifting It Right.** A hardcopy version of the *Lifting It Right* safety manual from the Automotive Lift Institute.



**Uniform Warning Labels and Placards for 2-Posts.** Labels in Mandarin, French Canadian, and Spanish are also available.



**Safety Tips Card.** Reminds your people of 13 key safety tips to follow daily.

**Visit today and get the training and materials you need to work safely:**  
[www.autolift.org/ali-store/](http://www.autolift.org/ali-store/)





---

**BendPak**<sup>®</sup>

1645 Lemonwood Drive  
Santa Paula, CA 93060 USA  
[bendpak.com](http://bendpak.com)