



**Ventura County Community College District**  
761 East Daily Drive, Camarillo, CA 93010  
Purchasing Department

TO: All Bidders January 9, 2020  
FROM: Janice Kisch, Purchasing Specialist  
SUBJECT: Bid 599 Moorpark College Physical Science Mass Spectrometer Project

**Bid 599 Moorpark College Physical Science Mass Spectrometer Project – Addendum 1**

This addendum is hereby made a part of the contract documents to the same extent as though it was originally included therein and takes precedence over the original documents.

**Note that the Bid Proposal Form requires acknowledgement of receipt of all addenda.**

It is the responsibility of the Bidder to verify that their Bid Proposal and all addenda has been received and delivered to the VCCCD Purchasing Department prior to the bid opening date and time. Verification of receipt can be obtained through the listed Purchasing Specialist.

---

**New Information:**

1. Pinnacle Mass Spectrometer Equipment manual
2. CONCOA Precision Gas Controls equipment flyer. Contact: Loushel Troxell  
757-321-8384

**Questions Asked and Answers:** The following are questions from the job walk:

3. Is it acceptable to use appropriate Concoa Gas Regulators on the project?  
Answer – *Yes is an acceptable product. Verify gas bottle connections from Air Gas Simi Valley prior to ordering. Equipment flyer is attached.*  
Contact: Loushel Troxell at 757-321-8384
4. Please provide Pinnacle Mass Spectrometer Equipment manual  
Answer – *Manual Attached*

# PinAAcle 500/900 AA Spectrometers

## Atomic Absorption

### Preparation Checklist

- Suitable working area
- Exhaust vent
- Atomic absorption gases
- Handling of gas cylinders and safety practices
- Drain vessels
- Graphite furnace and flame requirements
- Facilities requirements
- Important accessories and consumables

This document provides detailed instructions regarding the space, accessories and utilities required to operate PerkinElmer's PinAAcle™ 500 and 900 family of atomic absorption (AA) spectrometers, THGA and HGA graphite furnace systems, and other major AA accessories.

PerkinElmer AA instruments are complete systems with the exception of the following items which must be provided by the analyst: suitable working area; exhaust vent(s); gases and regulators; and light sources. When a THGA or HGA graphite furnace system is being used, additional items may be required, which are described in Section 8. General information on each of the required items is given in the appropriate section of this document.



PinAAcle 500 Flame AA Spectrometer



PinAAcle 900 Series AA Spectrometers

## 1 Suitable Working Area

The environment in which any instrument is housed is an important consideration. The room temperature should be between 15 and 35 °C (59-95 °F) with a maximum rate of change of 3 °C (5 °F) per hour. For optimum instrument performance, the room temperature should be controlled at 20 +/-2 °C. The instrument should be located away from direct sources of heat or cold. The relative humidity should be between 20 and 80%, non-condensing.

A relatively dust-free environment is necessary. This is especially important when working with ultra-trace techniques, such as graphite furnace sampling. Other important considerations are to locate the instrument in an area free of corrosive fumes and vibration and in an area that does not receive direct sunlight. This precision instrumentation is not designed to withstand vibrations from earthquakes. The instrument should be located away from radiators and at least 6 feet away from any A/C or heating ducts.

AA spectrometers are normally installed on laboratory work benches or tables. The benchtop or area in which the AA instrument is to be installed should be large enough to accommodate the instrument and all accessories (dimensions of those items are given in Section 10). A custom PinAAcle heavy-duty rolling bench, with locking casters and a lower shelf for storage, can be ordered (Part No. N0777783). Make sure that there is space at the rear and sides of the system for air to circulate freely. Do not block the fan operating on both sides of the instrument. The back of the instrument should not be placed permanently against a wall, as the instrument must be accessible from the back for servicing purposes. An accessible space of at least 60 cm (24 in.) should be available behind the instrument. If this is not possible, the table or bench on which the instrument is mounted should be on wheels so that it can be easily moved. The vent drop should be flexible so that it can be moved out of the way when the instrument is serviced. It is much easier to install and service an instrument that is on a rolling bench.

A means of electrically grounding the instrument and all accessories must be available.

### Atomic Absorption System Layout

In addition to the basic requirements for atomic spectroscopy systems, preparation of your laboratory for atomic absorption (AA) spectrometers equipped with graphite furnaces requires that consideration be given to the installation needs of the furnace power supply.

**WARNING:** The use of atomic absorption instruments without adequate ventilation to outside air may constitute a health hazard. For example, the combustion of halogenated hydrocarbons produces toxic vapors. Extreme care should be taken that exhaust gases are vented properly.

FIAS (flow injection for atomic spectroscopy) systems and flame autosamplers should be placed on a cart or table close to the AA spectrometer sample compartment to keep FIAS and/or autosampler tubing to a minimum length. The FIAS system and/or autosampler can also be placed to the side of the instrument – however, maximum performance may be compromised due to the increased length of tubing required. With self aspiration of the nebulizer, the uptake rate is greatly affected by the length of the tubing.

## 2 Exhaust Vent

A venting system is required to remove the combustion fumes and vapors from the flame or graphite furnace for AA instruments. Exhaust venting is important for a number of reasons:

- It will protect laboratory personnel from toxic vapors which may be produced by some samples.
- It will tend to remove the effects of room drafts and the laboratory atmosphere on flame stability.
- It will help to protect the instrument from corrosive vapors which may originate from the samples.
- It will remove dissipated heat which is produced by the flame or furnace.

A flow rate of approximately 5700-8500 L/min (200-300 cubic feet/min) is required for an air/acetylene flame and furnace operation. A flow rate of approximately 7000-8500 L/min (250-300 cubic feet/min) is required for nitrous oxide/acetylene flame operation. Though we do not specify a maximum flow rate, more than 20% above the recommended flow rate of 300 cubic feet/min will also affect stability of the flame, thus the precision of measurement. It is strongly recommended that the instrument not be placed in a chemical hood! If a chemical hood must be used, arrangements should be made to keep out corrosive vapors and backdrafts from other hoods.

Sample preparation should not be carried out in the same hood where the instrument is located.

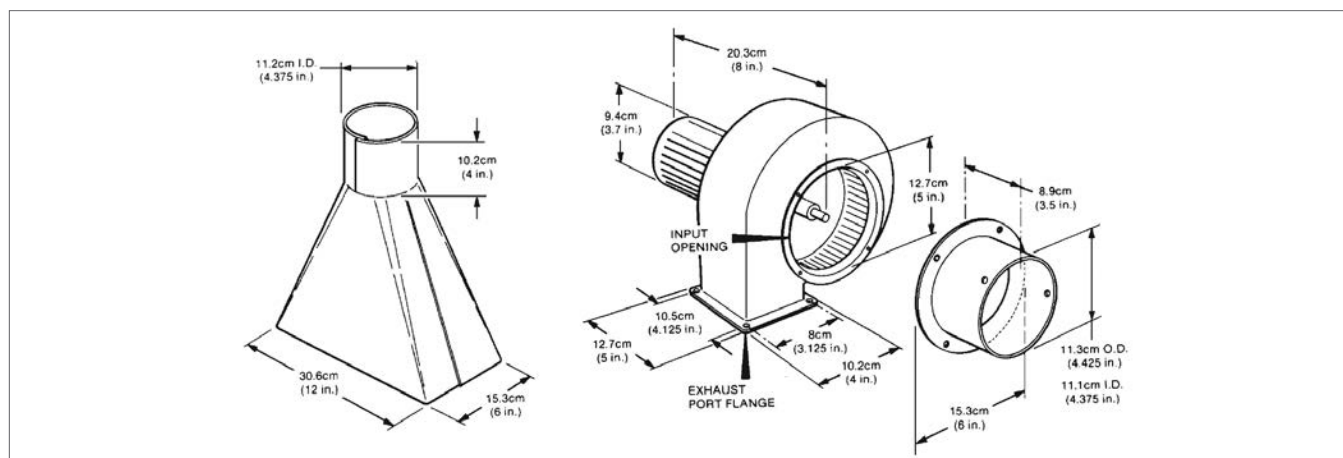

Figure 1. Blower and vent kit dimensions.

PerkinElmer offers an accessory, Blower and Vent Kit (Part No. 03030448 for 230 VAC; Part No. 03030447 for 115 VAC), which will fulfill the exhaust requirements for all AA instruments (see Figure 1). The blower capacity is for one instrument. Included in the kit are a rotary blower with capacitor and hardware, a vent to be located above the instrument, and an adapter to permit connection of the blower and vent with suitable metal tubing. The adapter and vent are made of stainless steel sheets.

**NOTICE:** Local electrical codes do not permit PerkinElmer Service Engineers to install the blower and vent assembly.

The metal tubing required to connect the vent to the blower and to provide suitable exhaust from the blower is not included in the Blower and Vent Kit. Flexible stainless steel tubing is recommended for this purpose and can be obtained from the companies listed in Table 1 and from various other firms. In some instances, this type of flexible metal tubing is sold only in minimum lengths of 3 meters (10 feet).

Table 1. U.S. Suppliers of Flexible Metal Duct Tubing.

<p><b>Flexaust Co.</b> 11 Chestnut St. Amesbury, MA 01913 (508) 388-9700</p>	<p><b>Potomac Rubber Co.</b> 9011 Hampton Overlook Capital Heights, MD 20743 (301) 336-7400</p>
<p><b>Triplex Inc.</b> 1142 Kress St. Houston, TX 77020 (713) 672-7521</p>	<p><b>Fox Manufacturing Inc.</b> P.O. Box 1047 Clarkdale, AZ 86324 (602) 634-5897</p>

For the names of suppliers in other areas, contact your PerkinElmer representative.

The capacity of the blower depends on the duct length and the number of elbows or bends used to install the system. If an excessively long duct system or a system with many bends is used, a stronger blower may be necessary to provide sufficient exhaust volume. Alternatively, smooth stainless steel tubing may be used instead of flexible stainless steel tubing where flexibility is not required to reduce system friction loss or “drag.” A length of smooth stainless steel ducting has 20-30% less friction loss than a comparable length of flexible ducting. When smooth stainless steel tubing is used, elbows must be used to turn corners. These elbows should turn at a center line radius of 45 degrees to reduce friction losses, and the number of elbows should be minimized.

If a rigid tubing system is used, it is strongly recommended that flexible tubing be used from the vent hood to the ceiling to facilitate hood alignment and service access to the instrument. The exhaust vent cannot prevent removal of the instrument covers.

The dimensions for the various parts of the Blower and Vent Kit are shown in Figure 1. The vent i.d. is slightly larger than the tubing o.d. to allow for tubing tolerances. A slight gap between the two units is normal.

When installing such a venting system, all connections should be made with metal screws or rivets. Solder must not be used. The blower should be located at least 4 meters (12 feet) and not more than 6.5 meters (20 feet) from the flame or the graphite furnace and should exhaust to the atmosphere or into a considerably wider exhaust duct. Under these conditions, the following temperatures

have been measured during operation of a nitrous oxide-acetylene flame: 310 °C at the vent intake; 160 °C at 2.4 meters (8 feet) from the vent intake; 105 °C at the blower intake; and 50 °C at the blower motor housing near the front bearing.

Instructions for installation (Part No. 09936775) are provided with the Blower and Vent assembly. The blower provided in the PerkinElmer accessory kit requires a line voltage of 115 V or 230 V.

Additional recommendations on the venting system include:

- Make sure the duct casing is installed using fireproof construction. Route ducts away from sprinkler heads.
- Locate the discharge outlet as close to the blower as possible. All joints on the discharge side should be airtight, especially if toxic vapors are being carried.
- Equip the outlet end of the system with a backdraft damper and take the necessary precautions to keep the exhaust outlet away from open windows or inlet vents and to extend it above the roof of the building for proper dispersal of the exhaust.
- Equip the exhaust end of the system with an exhaust stack to improve the overall efficiency of the system.
- Make sure the length of the duct that enters into the blower is a straight length at least ten times the duct diameter. An elbow entrance into the blower inlet causes a loss in efficiency.
- Design local exhaust ventilation systems individually for each specific AA instrument. Also, the opening of the exhaust vent should be large enough to cover the graphite furnace or flame area completely.
- Provide make-up air in the same quantity as is exhausted by the system. An “airtight” lab will cause an efficiency loss in the exhaust system.
- Ensure that the system is drawing properly by using an anemometer (Part No. N3134065) to accurately measure the exhaust flow rate.
- Equip the blower with a pilot light located near the instrument to indicate to the operator when the blower is on.

### 3 Atomic Absorption Gases

**NOTICE:** Standards for cylinder dimensions, regulator connections, gas fittings, etc. vary from country to country. The information provided here is for the U.S. Contact your PerkinElmer representative for information on the specific requirements of your area.

#### Compressed Air

For flame operation, the air supply should provide a minimum of 28 liters/min (1 cubic foot/min) at a minimum pressure of 350 kPa (50 psig). The pneumatics of the PinAAcle 500, 900H and 900T systems require an air pressure of 350-400 kPa (50-58 psig).

It is desirable to have a water and oil trap or filter between the compressor and the instrument gas control system. The use of an Air Filter Accessory (Part No. N0775325) or an Air/Acetylene Filter Accessory (Part No. N9301398) is strongly recommended to remove entrained water, oil, water aerosols and solid particles from compressed air lines. Filter elements need to be replaced every 6-12 months, provided the compressed air supply is properly maintained.

**WARNING:** When using an air or air/acetylene accessory, never exceed 1050 kPa (150 psig) for the air input pressure.

If there is any doubt regarding the usability of a central air supply (insufficient volume or pressure or excessive oil or water contamination), the quality of the supply should be checked prior to the arrival of the instrument. A small, oil-less air compressor meeting the stated requirements is available from PerkinElmer (AA Ultra Quiet Oil-Less Air Compressor 115V/60HZ - Part No. N9306345; AA Ultra Quiet Oil-Less Air Compressor 220V/50-60 Hz - Part No. N9306346).

Air compressors are generally uncomfortably noisy to have in the immediate vicinity of the instrument. Whenever possible, it is advisable to locate them at some distance from laboratory workers in an area providing suitable ventilation.

Cylinders of compressed air can also be used but are recommended only as an emergency or short-term solution for the following reasons:

- A standard #1 size air cylinder contains about 6200 liters (220 cubic feet) of air at standard temperature and pressure (STP). A premix burner-nebulizer system uses about 20 liters/min (0.7 cubic feet/min), and, therefore, a cylinder will last only about five hours. Unless an instrument is used only a few hours per day, changing cylinders becomes a nuisance as well as being expensive.
- Occasionally, cylinder air may be obtained from a liquefaction process during which the oxygen-to-nitrogen ratio can change. Therefore, it is not uncommon to find other than 20% oxygen in air cylinders. This can cause erratic burner operation and non-reproducible analytical results and, in extreme cases, may provide a potential safety hazard. In general, if cylinder air is to be used, it is important to specify *compressed* air rather than breathing air (i.e. medical grade) or an unspecified form.

**WARNING:** For safe operation, oxygen must NEVER be used with PerkinElmer premix burner systems.

The use of air cylinders requires the use of a suitable dual-stage regulator. A regulator for cylinders with a CGA 590 connection is available from PerkinElmer (Part No. 03030264).

**NOTICE:** In order to minimize flame ignition problems, the following size piping is recommended for long distances of the air source to the laboratory where it is used in our instrumentation:

- > 100 feet < 300 feet - 3/8" I.D. copper or stainless steel;
- > 100 meters - 1/2" I.D. copper or stainless steel.

## Acetylene

For the overwhelming majority of analyses, acetylene is the preferred fuel gas with AA spectrometers. Air/acetylene is the preferred flame for the determination of about 35 elements by AA. All PerkinElmer AA flame instruments require acetylene for the fuel. The temperature of the air/acetylene flame is approximately 2300 °C. For most air/acetylene flames, the acetylene flow used is about 4 liters/min or 0.14 cubic feet/min. Using a heat-combustion value of 1,450 BTU per cubic foot, the heat given off would be approximately 12,300 BTU per

hour (3,600 W). An air/acetylene flame can be used with all PerkinElmer burner heads but is most commonly used with the supplied 10 cm (4-inch) burner head.

Suitable acetylene typically has a minimum purity specification of 99.6% with the actual assay being about 99.8%. In general, ordinary welding-grade acetylene is adequate for most AA analyses, though sometimes a particular tank may be contaminated. Special higher purity "atomic absorption" grade acetylene is also available from some vendors, and its use is recommended when the available welding-grade acetylene is not sufficiently pure.

A size 1A acetylene cylinder contains about 8,500 liters (300 cubic feet) of acetylene and usually lasts about 30 hours of burning time with an air/acetylene flame. The cylinder requires an acetylene pressure regulator, which can be obtained from the supplier of the gas or from PerkinElmer (Part No. 03030106).

**CAUTION:** Acetylene may react with copper to form a potentially explosive compound. Copper tubing or fittings for acetylene gas must be strictly avoided.

The PerkinElmer Acetylene Regulator Assembly includes an adapter so that the pressure regulator can be connected to cylinders requiring either CGA 300 or CGA 510 fittings as well as a connector for attaching the fuel hose assembly supplied with the instrument. The fuel hose assembly is constructed of red neoprene, reinforced with high tensile-strength rayon cord, and provides a rated working pressure of about 1700 kPa (250 psig). The connectors are permanently mounted at each end of the hose assembly for connection to the pressure regulator and instrument gas controls, and use left-hand threads as per accepted practice for fuel gas connections. (See Section 5 for more details.) The rigorous gas hose testing is negated if a fitting is removed and replaced with another fitting.

It may be desirable to have an acetylene filter between the acetylene tank and the instrument gas control system to remove particulates and acetone droplets from acetylene, protecting the gas controls and AA burner system from contamination and corrosion. An Acetylene Filter (Part No. N9301399) and an Air/Acetylene Filter Accessory (Part No. N9301398) are available from PerkinElmer. Some countries also require the use of a flashback arrestor, such as PerkinElmer Part No. N9300068, in the acetylene fuel line.

Acetylene is normally supplied dissolved in acetone, and a small amount of acetone carryover with the acetylene is normal. However, as tank pressure falls, the relative amount of acetone entering the gas stream increases and can give erratic results, particularly for elements such as calcium, tin, chromium, molybdenum and others whose sensitivity is highly dependent on the fuel/oxidant ratio. For this reason, acetylene tanks should be replaced when the cylinder pressure drops to about 600 kPa (85 psig).

**IMPORTANT:** Failure to change the acetylene cylinder before the cylinder pressure drops below 600 kPa (85 psig) may cause damage to valves or tubing within the burner gas control system due to high acetone carryover. Such damage from acetone is not covered by instrument warranties. Improper storage of an acetylene tank could also cause acetone to enter the burner gas control system.

Since the acetylene is dissolved in acetone, the pressure drop is not linear with gas removal, and a pressure of 600 kPa (85 psig) indicates that the cylinder is nearly empty, assuming the cylinder is at room temperature.

Acetylene tanks should always be stored and operated in a vertical position, rather than horizontally, to prevent liquid acetone from reaching the cylinder valve. New tanks should be positioned vertically for at least 8 hours prior to use. The practice of "cracking the valve" of an acetylene tank (that is, opening the valve slightly for a very short period prior to attaching the regulator) is not recommended. While such an action will clear the valve opening of dust or dirt particles and may remove acetone from the cylinder valve, it is a potentially hazardous practice and one which should never be attempted in the presence of an open flame, sparks or other possible sources of ignition.

*CAUTION: Acetylene-line pressure from the cylinder to the instrument should never be allowed to exceed 103 kPa (15 psig). At higher pressures, acetylene can spontaneously decompose or explode. PerkinElmer recommends that a maximum acetylene line pressure of 80-95 kPa (12-14 psig) be used to provide a reasonable margin of safety.*

Both fuel and oxidant gas lines should be relieved of pressure at the end of the working day or if the instrument is to remain unused for an extended period. Cylinder valves should be closed to avoid the possibility of pressure regulators failing and gas lines being subjected to the full cylinder pressure.

*NOTICE: In order to minimize flame ignition problems, the following size piping is recommended for long distances of the acetylene source to the laboratory where it is used in our instrumentation:*

- > 100 feet < 300 feet - 3/8" I.D. stainless steel - do not use copper;
- > 100 meters - 1/2" I.D. stainless steel - do not use copper.

## Nitrous Oxide

The nitrous oxide/acetylene flame has a maximum temperature of approximately 2800 °C and is used for the determination of elements that form refractory oxides. It is also used to overcome chemical interferences that may occur in flames of lower temperatures. For the nitrous oxide/acetylene flame, the acetylene flow is about 14 liters/min or 0.5 cubic feet per min. Using a heat of combustion value of 1,450 BTU per cubic foot, the heat given off would be approximately 43,000 BTU per hour (12,500 W).

The use of nitrous oxide requires a number of accessories and precautions. A size 1A cylinder of nitrous oxide contains about 14,800 liters (520 cubic feet) and will typically last for 10 to 12 hours of burning time. Cylinders of nitrous oxide (99.0% minimum purity) are available from local suppliers. A dual-stage regulator is recommended (and is mandatory in some countries).

Nitrous oxide is supplied in the liquid state, initially at a pressure of about 5000 kPa (750 psig). Since nitrous oxide is in liquid form, the pressure gauge does not give a true indication of how much nitrous oxide remains in the cylinder until the pressure starts to fall rapidly as the residual gas is drawn off. There is no drop in pressure until all of the liquid nitrous oxide is consumed. The tank

is basically empty when all of the liquid nitrous oxide is consumed.

When nitrous oxide is rapidly removed from the cylinder, the expanding gas causes cooling of the cylinder pressure regulator and the regulator diaphragm sometimes freezes. This can create erratic flame conditions or, in the most extreme case, a flashback. It is therefore advisable to heat the regulator using either a built-in heater or an externally supplied heat source, such as an electrical resistance heating tape.

*CAUTION: All lines carrying nitrous oxide should be free of grease, oil or other organic material, as it is possible for spontaneous combustion to occur. Cylinders of nitrous oxide should be considered high-pressure cylinders and should be handled with care at all times.*

A dual-stage heated nitrous oxide pressure regulator for use with gas cylinders with a CGA 326 connection is available from PerkinElmer (Part No. 03030204 [115 VAC] or 03030349 [230 VAC]). These regulators provide pressure control from 350-520 kPa (50-75 psig) and contain an integral thermostatted heater to prevent freezing of the regulator diaphragm. A color-coded hose with suitable connectors at each end is supplied with the regulators to provide connection to the instrument gas controls (see Section 5).

*NOTICE: In order to minimize flame ignition problems, the following size piping is recommended for long distances of the nitrous oxide source to the laboratory where it is used in our instrumentation:*

- > 100 feet < 300 feet - 3/8" I.D. copper or stainless steel;
- > 100 meters - 1/2" I.D. copper or stainless steel.

## Argon

Argon is required for external and internal gas streams through the THGA or HGA graphite furnace or as a carrier gas with mercury/hydride systems such as the FIAS or FIMS flow injections systems or the MHS-15. The quality criteria listed in Table 2 for argon are suitable for these applications. Normally, for graphite furnace operation, gaseous argon is used, although either liquid or gaseous argon can be used. The choice of liquid argon or gaseous argon tanks is determined primarily by the availability of each and the usage rate. Liquid argon is usually less expensive per unit volume to purchase, but cannot be stored for extended periods. If liquid argon is used, the tank should be fitted with an over-pressure regulator which will vent the tank as necessary in order to keep the liquid argon cool enough to remain in the liquid state. Gaseous argon tanks do not require venting and consequently can be stored for extended periods without loss.

A dual-stage cylinder regulator that can be used with either gaseous argon or nitrogen is available from PerkinElmer (Part No. 03030284). The regulator has a CGA 580 fitting, and includes a color-coded hose with 1/4-inch Swagelok® fittings to permit direct connection to the regulator and to the instrument gas controls (see Section 5).

Table 2. Quality Criteria for Argon.

Criterion	Specification
Purity	≥ 99.996%
Oxygen	≤ 5 ppm
Nitrogen	≤ 20 ppm
Water	≤ 4 ppm

## 4 Gas Line Connections

PerkinElmer AA instruments include the hoses necessary for connection to gas lines (see Table 3). It is the responsibility of the user to provide the appropriate gas lines, regulators, connectors and valves to which the hoses are connected.

## 5 Handling of Gas Cylinders and Other Safety Practices

*NOTICE: The permanent installation of gas supplies is the responsibility of the user and should conform to local safety and building codes.*

- Flammable gas cylinders (such as acetylene) should not be stored with oxygen, or nitrous oxide cylinders, or adjacent to oxygen-charging facilities.
  - Cylinders of nitrous oxide stored inside buildings should not be located in close proximity to cylinders of flammable gases (acetylene). Unless separated by a minimum of 20 feet, there shall be a fire-resistive partition between the nitrous oxide cylinders and the flammable gas cylinders.
  - Fasten all gas cylinders securely to an immovable bulkhead or a permanent wall.
  - When gas cylinders are stored in confined areas, such as a room, ventilation should be adequate to prevent toxic or explosive accumulations. Move or store gas cylinders only in a vertical position with the valve cap in place.
  - Locate gas cylinders away from heat or ignition sources, including heat lamps. Cylinders have a pressure-relief device that will release the contents of the cylinder if the temperature exceeds 52 °C (125 °F).
  - When storing cylinders external to a building, the cylinders should be stored so that they are protected against temperature extremes (including the direct rays of the sun) and should be stored above ground on a suitable floor.
  - Mark gas cylinders clearly to identify the contents and status (full, empty, etc.).
  - Full cylinders should not be stored with empty cylinders.
  - Do not attempt to refill gas cylinders.
  - Use only approved regulators and hose connectors. Left-hand thread fittings marked with hatch marks are used for fuel gas tank connections, whereas right-hand fittings are used for oxidant and support gas connections.
  - Use galvanized iron tubing, steel, wrought iron or other tubing that will not react chemically with acetylene. Never use copper tubing with acetylene. Joints may be welded or made up of threaded or flanged fittings, typically stainless steel, aluminum or brass composed of less than 65% copper. Rolled, forged or cast steel or malleable iron fittings may also be used. Cast iron fittings cannot be used safely for acetylene lines.
  - Arrange gas hoses where they will not be damaged or stepped on and where things will not be dropped on them.
  - Never run acetylene at a pressure higher than 100 kPa (15 psig). At pressures above this level, acetylene may spontaneously explode.
- Perform periodic gas leak tests by applying a soap solution to all joints and seals.
- WARNING: Contact between acetylene gas and copper or silver (or high concentrations of silver salts), liquid mercury or gaseous chlorine can produce potentially unstable acetylides. Always clean the burner thoroughly after analyzing solutions with high silver, copper, or mercury concentrations, and aspirate solution continuously during the analysis to prevent any residues from drying.*
- Periodically check for the presence of acetylene in the laboratory atmosphere, especially near the ceiling.
  - When the equipment is turned off (for example, at the end of the working day), close all gas cylinder valves tightly at the tank. Bleed the remainder of the line to the atmosphere before the exhaust fan (vent) is turned off.
  - When using premix burners with cyanide solutions, check the pH of the liquid trap and drain vessel. The pH of the liquid should be greater than 10. If the liquid is even slightly acidic, highly toxic hydrogen cyanide gas may be released. Never allow an acidic solution to enter a drain bottle that contains a cyanide solution.
  - Take suitable precautions when using volatile organic solvents. A potentially flammable organic vapor “cloud” can form around the opening of the sample vessel. Feeding the capillary tubing through a small hole in a covered sample container is one way of reducing the possibility for ignition.
  - Never view the flame, hollow cathode lamps (HCLs), electrodeless discharge lamps (EDLs) or deuterium background corrector lamps directly without protective eyewear. Potentially hazardous ultraviolet radiation may be emitted. Ordinary safety glasses will in general provide sufficient protection, but additional side shields will ensure a further margin of safety. Safety glasses will also provide mechanical protection for the eyes.
  - Never leave the flame unattended.
  - Zeeman background-corrected AA instruments generate a strong magnetic field. People with cardiac pacemakers are advised not to operate or frequent the vicinity of Zeeman corrected instruments while they are in operation.

## 6 Drain Vessels

A specially-configured drain vessel is supplied with all PerkinElmer AA instruments with burner systems. That vessel must be used to gather the effluent from the AA burner drain.

The drain vessel should NOT be stored in an enclosed storage area. Rather, the drain vessel should be stored in plain sight of the operator, usually on the floor in front of the instrument or on an open shelf underneath the instrument table.

The drain system should be checked regularly and replaced when necessary. Follow the directions in the instrument manuals regarding the proper placement of the drain tube in the drain vessel and the proper liquid level in the drain vessel.

## 7 Atomic Absorption Source Lamps

AA spectrometers require different source lamps, depending on the elements to be determined and the instrument to be used. Multielement lamps are available for some elements, but most lamps are constructed using a single element to avoid potential spectral interferences and reduced performance, especially when using a graphite furnace.

PerkinElmer manufactures all of its hollow cathode and electrodeless discharge lamps. The Lumina™ series of hollow cathode lamps are especially noted for spectral purity, brightness, stability and long life.

Hollow cathode lamps (HCLs) are excellent for most elements; however, there are a number of “difficult” elements for which an improved light source is desirable. PerkinElmer

System 2 electrodeless discharge lamps (EDLs) provide improved performance in most instances. EDLs are more intense than their corresponding HCLs. Most also provide better lamp life and stability as well as better sensitivity. EDLs do not require a separate power supply as it is built into the PinAAcle systems.

A lamp mount or turret is supplied with all PerkinElmer AA instruments and will accommodate all PerkinElmer HCLs or EDLs. Users who may have lamps with 1.5 inch diameters rather than the standard PerkinElmer 2 inch diameter can adapt those lamps for use in PerkinElmer lamp mounts with the Small Diameter Lamp Adapter Kit, (Part No. 03030870).

Removing a lamp without switching it off first may damage the lamp permanently.

Table 3. Gas Line Connections (Note: Regulator, connector and fitting needs vary by country. For information on what is required in your area, consult your local PerkinElmer Service Representative.)

Gas	Regulator Part Number	Regulator to Cylinder CGA No.	Regulator Connection to Gas Hose Assembly	Hose Assembly Connections			
				Part Number	Color	Connection to Regulator	Connection to Instrument
Air	03030264	590	1/4" Swagelok®	00570567	black	1/4" Swagelok®	1/4" Swagelok®
Argon	03030284	580	1/4" Swagelok®	00570567	black	1/4" Swagelok®	1/4" Swagelok®
Nitrogen	03030284	580	1/4" Swagelok®	00570567	black	1/4" Swagelok®	1/4" Swagelok®
Nitrous Oxide	03030204	326	1/4" N.P.T.*	00470258	blue	5/16" Swagelok®	5/16" Swagelok®
Acetylene	03030106	510 or 300	9/16" L.H.T.**	00570559	red	9/16" L.H.T.	3/8" L.H.T.

N.P.T. = Normal Pipe Thread, L.H.T. = Left-Hand Thread

\* Supplied with 5/16" x 1/4" N.P.T. Swagelok® Male connector Body (Part No. 09903946).

\*\* Supplied with Outlet Bushing (Part No. 09903031), 1/4" N.P.T. to 9/16" L.H.T.

PerkinElmer Air Compressor (Part No. N9306345 for 115 V/60 Hz; Part No. N9306346 for 220 V/50-60 Hz) provides a 1/4" Swagelok® fitting.

PerkinElmer Air Filter Assembly (Part No. N0580531) provides 1/4" Swagelok® inlet and outlet fittings. Recommended for argon that is supplied to a furnace.

PerkinElmer Air Dryer Filter Assembly (Part No. N0775325) provides 1/4" Swagelok® inlet and outlet fittings.

PerkinElmer Air/Acetylene Filter Assembly (Part No. N9301398) provides 1/4" Swagelok® inlet and outlet fittings for air and 3/8" LH (A size) inlet and 9/16" LH (B size) outlet fittings for acetylene.

PerkinElmer Acetylene Filter (Part No. N9301399) provides 3/8" LH (A size) inlet and 9/16" LH (B size) outlet fittings.

### Also Available:

1. Part No. 09903032 Connector for joining two Part No. 00570559 fuel hose assemblies
2. Part No. 09903898 Connector for joining two Part No. 00570567 air/argon hose assemblies
3. Part No. 09903196 Adapter, female 1/4" N.P.T. to male 1/4" Swagelok®
4. Part No. 09920223 Connector for joining two 00470258 nitrous oxide hose assemblies
5. Part No. N3180520 Gas Hose Adapters Kit



## 8 Graphite Furnace and Flame Requirements

### Location

The flame and furnace power supply is built into the PinAAcle 500 and 900 spectrometers.

### Electrical Services

The PinAAcle 500 and 900F flame-only systems require a dedicated circuit and wiring size selected according to local regulations which provide power specifications that meet the following criteria: 100-230 VAC +10/-15 VAC, 50 or 60 Hz +/- 3 Hz, and single phase alternating current with a maximum power consumption capability of 800 VA. The operating range of the electrical line should meet the required specifications of 85-253 VAC, 4A-8A, and 47-63 Hz for the PinAAcle 500 and 900F.

Graphite furnaces require electrical power, cooling water and a supply of inert gas, normally argon. A minimum input voltage of 207 VAC is recommended under load to enable the furnace to reach maximum potential operating temperatures and heating rate and, for some systems with Zeeman effect background correction, proper magnetic field strength. For installations where the line voltage may drop below this level, the use of a "buck boost"-type transformer is recommended to maintain proper analytical operating conditions. Please refer to the Buck-Boost Transformers table on page 12 for details. Running a ZL furnace below the minimum voltage can cause permanent damage to the power supply.

An appropriately-rated female electrical connector is required to provide power for the graphite furnace and flame systems. Please contact your local PerkinElmer Service Engineer to determine the appropriate connector for your laboratory.

*NOTICE: For 120 VAC power flame-only instrument installations, the use of an isolation ground receptacle (Part No. N3151390) is strongly recommend. It should be a dedicated circuit with a direct run of all three wires to the power panel. There should not be any grounding loops on the dedicated circuit.*

Electrical supply circuitry, circuit breakers and wiring size for the graphite furnaces should be selected according to local regulations. Three types of 3-wire circuits used in North America, which provide power adequate to run THGA or HGA systems, are illustrated in Figure 3 (page 10). The PinAAcle 900H requires a 230 VAC ( $\pm 10\%$ ), 50/60 Hz (+/- 0.3 Hz), 20-amp line capable of delivering 10.1 KVA of peak power. The operating range of the electrical line should meet the required specifications of 207-253 VAC, 20A, and 47-63 Hz for the PinAAcle 900H under full load of furnace atomization checked during installation.

There should be a dedicated circuit allocated for each installed instrument with no grounding loops.

The THGA furnace and Zeeman magnet of the PinAAcle 900Z and PinAAcle 900T systems operate from a single, dedicated electrical supply of 230 VAC ( $\pm 10\%$ ), 30 amp, 50 or 60 Hz ( $\pm 0.3$  Hz), single phase, capable of delivering 10.1 KVA of peak power. The operating range of the electrical line should meet the required specifications of 207-253 VAC, 30A, and 47-63 Hz for the PinAAcle 900T and 900Z under full load of furnace atomization checked during installation. The PinAAcle 900Z and 900T systems are provided with a 30-amp IEC 60309 32A power connector plug

on the instrument line cord. The PinAAcle 900T and 900Z also ship standard with an IEC 60309 250 VAC 32A Receptacle Kit (Part No. W1036805), that the IEC plug inserts into. The PinAAcle 900H system is provided with a 20-amp IEC 60309 16/20 A power connector plug on the instrument line cord. The PinAAcle 900H also ships standard with an IEC 309 250 VAC 16/20A Receptacle Kit (Part No. N0770425), that the IEC plug inserts into. For all PinAAcle 900 systems, the receptacle must be installed by a licensed electrician. The 20-amp plug supplied with the PinAAcle 900H can be adequately used for the operation of the PinAAcle 900H, though the use of a 30-amp plug provides additional safety margin for the power surge experienced during the furnace atomization step when peak power is used. This supplied 20-amp plug can be replaced with a 30-amp plug, if desired. It is recommended that 8-gauge (6 mm<sup>2</sup>) wire be used for the electrical supply for PinAAcle 900Z, and PinAAcle 900T systems, and that the length of the wiring (circuit breaker to instrument connection) not exceed 20 meters (65 feet). Although 10-gauge (6 mm<sup>2</sup>) wire can be used for the electrical supply of the PinAAcle 900H system, 8-gauge (10 mm<sup>2</sup>) wire is recommended. If the length of the wiring of the dedicated circuit from the power panel exceeds 20 meters/65 feet, the use of 6-gauge (16 mm<sup>2</sup>) is required.

*NOTICE: Do not replace the IEC instrument power plugs installed on PinAAcle instruments.*

For all furnace systems, the electrical supply should contain a "slow blow" circuit breaker capable of handling 300% of the rated current for periods of 3 seconds. Also, the AA spectrometer, graphite furnace, Zeeman magnet, computer and other accessories should all be connected to the same electrical ground, and the power supply should be free of transients in excess of 50 V over the nominal voltage.

### Additional Furnace Requirements

A water supply is required to cool the furnace quickly to ambient temperature after reaching high atomization temperatures. The water supply should be free of sediment, have a pH between 6.5 and 7.5, and a hardness not greater than 6 °dH or 100 ppm. A maximum flow of 2.5 L/min (0.6 gal/min) is used for the THGA, 1.5 liters/min (0.4 gal/min) for the HGA at a temperature between 20 °C and 40 °C. As both the flow rate and water temperature affect the cooling rate, it is desirable to be able to vary the flow rate to compensate for variations in cooling water temperature. A suitable recirculating cooling system is included with a number of THGA systems. With an HGA system, the use of an optional Recirculating Cooling System is strongly recommended. All PinAAcle 900 furnace systems (T, H, or Z), have a plug on the back of the instrument that supplies power to the cooling system. There is also a relay that turns the cooling system on during furnace operation. The cooling system will turn off after the furnace has been idle for 5 minutes. Since the relay controls the cooling system, the power switch on the back of the cooling system should be left in the "on" position. Do not allow the cooling water temperature to drop below 20 °C, or have too fast of a flow rate. This will cause condensation on the furnace windows and/or furnace. Condensation on the furnace will cause poor tube and contact cylinder life.

**CAUTION:** To prevent combustion of the graphite tube at high temperatures, the furnace is purged with argon.

It is not recommended to use nitrogen as the furnace purge gas. Its use may lead to reduced sensitivity for some elements, and it is also possible for nitrogen to react with the graphite tube at temperatures above 2300 °C to form cyanogen, a toxic gas.

When operating the HGA Graphite Furnace systems at high temperatures, do not look directly at the tube without suitable eye protection.

Maximum gas consumption is 0.7 liters/min (0.19 cubic feet/min) for THGA furnaces and 1.2 liters/min (0.3 cubic feet/min) for the HGA furnaces, both at 300-450 kPa (44-66 psig). Purity specifications for the gases to be used with HGA systems are given in Section 3. Ventilation is required to remove potentially toxic or corrosive gases which can be generated by the samples.

## 9 Training Courses

Training courses for users of PerkinElmer AA instruments are given at various locations. The courses cover basic principles and applications of atomic absorption and detailed instruction in the use of the instruments and major accessories.

To gain the most benefit from the training course, it is strongly recommended that the attendee should have operated the instrument for at least several weeks prior to the course.

For additional information on atomic spectroscopy training courses, please contact your local sales representative.

## 10 Facilities Required for PerkinElmer AA Instruments

The following figure and tables provide the dimensions and power requirements for PerkinElmer AA instruments and major accessories. Dimensions are defined in Figure 2. There must be a loading dock available for instrument delivery. There must also be a 36-inch door available for a crated entry of the instrument into the laboratory, or a 32-inch door to accommodate entry of an uncrated instrument. Internet access in the laboratory where the instrument will be installed is preferred. Required services are shown in Table 4, and product dimensions and approximate power consumption for AA spectrometers and major accessories are given in Table 5. PerkinElmer instruments will normally operate within the specified operating ranges of the electrical line defined in the Electrical Services section on page 8, unless otherwise noted. If the power line is unstable, fluctuates in frequency or is subject to surges or sags, additional control of the incoming power may be required. A means of electrically grounding the instruments and accessories must be available. Power to the instrument should be clean from excessive high frequency noise.

The ANSI-IEEE C62.41\* recommends <10 VAC normal mode (signal to ground) and <1/2 VAC common mode\*\* (neutral to ground). Can be verified with the use of an oscilloscope or logic analyzer and a Power Probe power meter tool.

\* American National Standards Institute (ANSI) is a private, non-profit organization that administers and coordinates the U.S. voluntary standards.

\*\* Institute of Electrical and Electronics Engineers (IEEE) is a professional association with its corporate office in New York City.

\*\* Excessive common mode (neutral to ground) noise can be caused by a poor building ground. The NEC (National Electrical Code) requires that the building ground resistance does not exceed 25 ohms. This can be verified with an earth ground test.

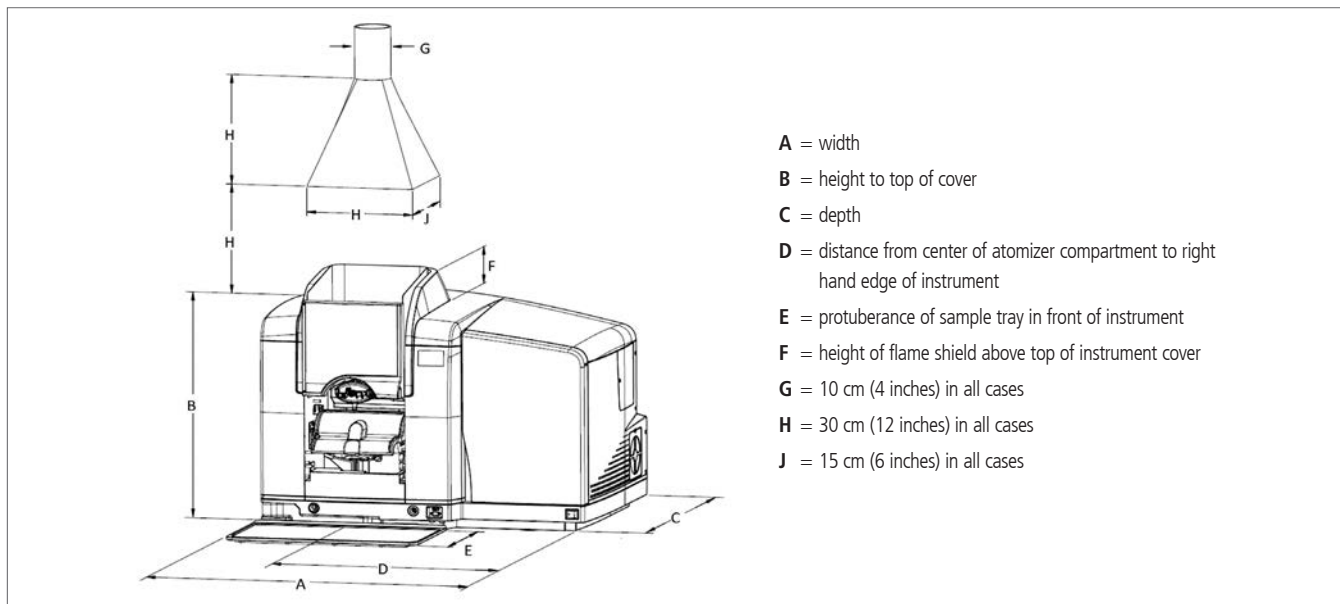

Figure 2. Spectrometer and accessories dimensions (Refer to Table 5).

Table 4. Required Services.

Instrument/ Accessory	Gases				Cooling Water	Computer Controlled	Req. No. of Vents	Electrical Power
	Air	N <sub>2</sub> O	C <sub>2</sub> H <sub>2</sub>	Ar				
PinAAcle 500	•	•	•			•	1	a
PinAAcle 900F	•	•	•			•	1	a
PinAAcle 900Z				•	e	•	1	b
PinAAcle 900H	•	•	•	•	c	•	1	b
PinAAcle 900T	•	•	•	•	e	•	1	b
FIAS 100/400				•		f	d	a
FIMS 100/400				•		•	d	a
Amalgamation Attachment	•			•		f		a
MHS-15				•			d	

a = 85-253 VAC, 4-8 A, 47-63 Hz, single phase

b = 207-253 VAC, 30 A, 47-63 Hz (under full instrument load), single phase

c = 207-253 VAC, 20 A, 47-63 Hz (under full instrument load), single phase

d = uses the same vent as the spectrometer

e = optional (included with some versions of the PinAAcle 900H/T/Z)

f = controlled from the spectrometer computer/controller

The FIMS 100/400 does not require a vent if only analyzing mercury and the charcoal filter is used.

The FIAS, FIMS (when used to analyze for hydrides), and MHS-15 units will use the vent that is over the instrument they are connected to. The FIMS does not require a vent when used to analyze for mercury, since the units are supplied with a mercury absorbing filter. If the amalgamation unit is attached to the FIAS, then it will use the instrument vent. If the amalgamation unit is attached to the FIMS, then it will use the mercury absorbing filter supplied with the FIMS.

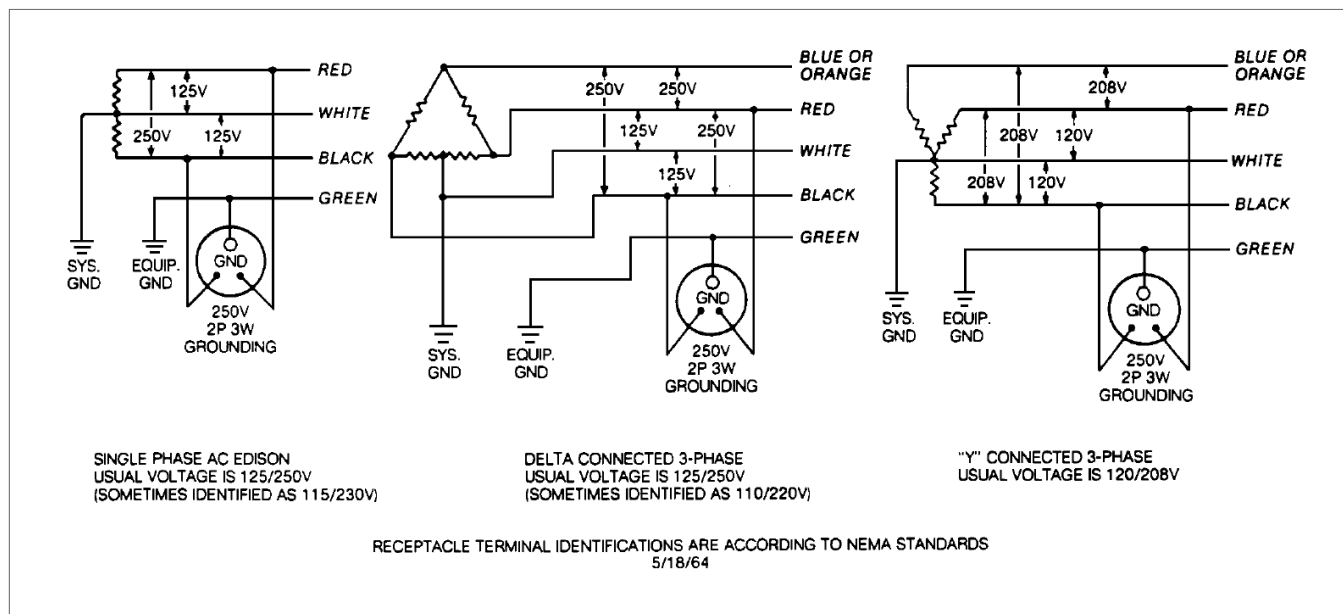

Figure 3. Furnace power circuit connection configurations.

Table 5. Instrument and Accessory Specifications (Refer to Figure 2).

Instrument/Accessory	Width (cm) A	Height (cm) B	Depth (cm) C	(cm) D	(cm) E	(cm) F	Power VA	Weight (Kg)
<b>Spectrometers:</b>								
PinAAcle 500	67	64	63	26	19.5	6.6	800	57
PinAAcle 900F	95	64	68	66	19.5	8.5	800	94
PinAAcle 900Z	95	64	68	66	19.5	8.5	10100	127
PinAAcle 900H	95	64	68	66	19.5	8.5	10100	123
PinAAcle 900T	95	64	68	66	19.5	8.5	10100	141
<b>Graphite Furnace Components:</b>								
AS 900 Autosampler	25	20	34				NA	6
HGA/THGA Cooling System	20	37.5	50				140	18
<b>Flame Autosamplers:</b>								
S10	42	56	34				360	4
<b>Mercury/Hydride System:</b>								
MHS-15	17	38	16				NA	3
<b>Flow Injection Systems:</b>								
FIAS 100/400	42	18	41				600	11
FIMS 100/400	42	26	41				450	12
Amalgamation Attachment	25	25	24				300	5
<b>FAST Flame Sample Automation Systems:</b>								
Switching Valve	20	10	9				NA	0.1
Peripumps	1: 9; 2: 17	13	10				NA	1: 1.6; 2: 2.8
Autosamplers (a) SC2 2-tray	54	15 without probe	34				200	18
(b) SC4 4-tray	77	15 without probe	34					22
<b>Lenovo® ThinkCentre® Computers:</b>								
CPU	18	44	40				690	11
24" LCD Monitor	55	50	20				350	25
Keyboard	46	5	18				NA	2
<b>Accessories:</b>								
AutoPrep™ 50 Autodilutor	34	39	20				60	7.5
Air Compressor	65	55	31				700	36
Heated N <sub>2</sub> O Regulator							150	2
HP® LaserJet® M601	42	40	41				350	20
Brother® HL-5440 Laser Printer	36	24	38				600	10.5
Brother® Compact all-in-one Inkjet Printer MFC-J650DW 120V	35	30	35				300	8
Brother® Compact all-in-one Inkjet Printer MFC-J870DW 220V	35	36	35				350	9

\* With the PinAAcle 900Z, 900H or 900T, the furnace autosampler projects 35 cm from the right front of the instrument in its storage position.

\*\* Height at maximum sample arm upward travel.

NA: Not applicable (powered by another device or included with another component)

## 11 Important Accessories and Consumables

### Line Conditioners



Instrument Models	Description	Instrument Input/ Output Voltage	Frequency	Part No.
PinAAcle 500/900F	840 VA Line Conditioner	120	60 Hz	N9307517
PinAAcle 500/900F	750 VA Line Conditioner	220	50 Hz	N9307521
PinAAcle 900H/T/Z	5.8 KVA Line Conditioner	208/240	60 Hz	N9307760
PinAAcle 900H/T/Z	6.0 KVA Line Conditioner	220	50 Hz	N9307523

### UPS Systems



Instrument Models	Description	Frequency	Part No.
PinAAcle 500/900F	800 VA UPS	60 Hz	N0777681
PinAAcle 500/900F	800 VA UPS	50 Hz	N0777689
PinAAcle 900H/T/Z	10 KVA UPS	50/60 Hz	N9306757

### Buck-Boost Secondary Transformers

Instrument Models	Description	Instrument Input/ Output Voltage	Frequency	Part No.
PinAAcle 900H/T/Z	Transformer- 2.0 KVA 16/32 VAC Buck-Boost	16/32	50/60 Hz	N9307525
PinAAcle 900H/T/Z	Transformer- 2.0 KVA 12/24 VAC Buck-Boost	12/24	50/60 Hz	N9307526

### Preventive Maintenance Kits

Instrument Models	Description	Qty	Part No.
<b>PinAAcle 500/900F Preventive Maintenance Kit 1 (Stainless Steel Neb)</b>			<b>N3160520</b>
	Tubing-Tygon SE-200 per 1 FT/0.3 M	4	02507987
	Burner Head Viton O-Ring	1	09902219
	End Cap O-Ring - Large	1	09902147
	End Cap O-Ring - Small	4	09200253
	Apiezon Grease Assy	1	03030405
	Neb Poly Tubing 10 FT AA	0.1	09908265
	Stainless Steel Neb O-Ring (0.364 ID 0.070 WD)	2	09902015
	Stainless Steel Neb O-Ring (0.176 ID 0.070 WD)	2	09902005
	Stainless Steel Neb O-Ring (0.208 ID 0.070 WD)	1	09902239
	Stainless Steel Neb O-Ring (0.070 ID 0.040 WD)	1	09902102
	Nebulizer PTFE Washer	1	03031802
	Burner Quick Connect O-Rings	6	09902047
	Media-Fan Filter (5/pack)	2	N2011156
	Clamp- Hose 7/32-5/8 SST (for 02507987)	2	09903004
<b>PinAAcle 500/900F Preventive Maintenance Kit 2 (High Sensitivity Neb)</b>			<b>N3160521</b>
	Tubing-Tygon SE-200 per 1 FT/0.3 M	4	02507987
	Burner Head Viton O-Ring	1	09902219
	O-Ring Metric 2ID 1WD	1	09926127
	End Cap O-Ring - Large	1	09902147
	End Cap O-Ring - Small	4	09200253
	Apiezon Grease Assy (Neb)	1	03030405
	High Sensitivity Neb O-Ring (0.364 ID 0.070 WD)	2	09902015
	Nebulizer Tubing Assembly	1	B3150458
	Ceramic Ball (Neb)	1	B0505086
	High-Sensitivity Neb O-Ring (0.070 ID 0.040 WD)	1	09902102
	Burner Quick Connect O-Rings	6	09902047
	Media-Fan Filter (5/pack)	2	N2011156
	Clamp- Hose 7/32-5/8 SST (for 02507987)	2	09903004

**Preventive Maintenance Kits, continued**

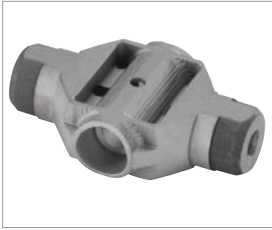

Instrument Models	Description	Qty	Part No.
<b>PinAAcle 500/900F Preventive Maintenance Kit 2 (High Sensitivity Neb) continued</b>			<b>N3160521</b>
	Adapter For Argon Gas (G3/8 Fittings )	1	N3160513
	Fittings For Flame Hoses (G3/8 Type )	1	N3160517
	FEP Tubing For Drainage (Convolute)	1	N3160518
<b>PinAAcle 900Z Preventive Maintenance Kit</b>			<b>N3160522</b>
	THGA Contact Cylinders -1 Pair	1	B0504035
	AS 900 Sampling Probe	1	B0129258
	Quad-Ring 25 X 3.53	1	B0501236
	PTFE Tubing (Clear) 1.75 ID X 2.45 OD	1	B0017998
	Media-Fan Filter (5/pack)	2	N2011156
	Ferrule Front 2.45	1	B3001333
	Ferrule Back 2.45	1	B3001334
	PTFE-Hose ID 1.0 X WD 0.3	1	B0029792
	Back Ferrule 1/16"	1	B0080196
	Front Ferrule 1/16"	1	B0080197
	Cleaning Tips (10/pack)	1	B0505368
	Outlet-Valve CPL	1	B3002006
	Inlet-Valve CPL	1	B3002007
<b>PinAAcle 900H Preventive Maintenance Kit 1 (Stainless Steel Neb)</b>			<b>N3160525</b>
	Contact Cylinders – 1 Set	1	B0128495
	AS 900 Sampling Probe	1	B0129258
	Collar - Window Holder	1	B3120294
	Tubing-Tygon SE-200 per 1 FT/0.3 M	4	02507987
	Burner Head Viton O-Ring	1	09902219
	End Cap O-Ring - Large	1	09902147
	End Cap O-Ring - Small	4	09200253
	Apiezon Grease Assy	1	03030405
	Neb Poly Tubing 10 FT AA	0.1	09908265
	Stainless Steel Neb O-Ring (0.364 ID 0.070 WD)	2	09902015
	Stainless Steel Neb O-Ring (0.176 ID 0.070 WD)	2	09902005
	Stainless Steel Neb O-Ring (0.208 ID 0.070 WD)	1	09902239
	Stainless Steel Neb O-Ring (0.070 ID 0.040 WD)	1	09902102
	Nebulizer PTFE Washer	1	03031802
	Burner Quick Connect O-Rings	6	09902047
	PTFE Tubing (Clear) 1.75 ID X 2.45 OD	1	B0017998
	Back Ferrule 1/16"	1	B0080196
	Front Ferrule 1/16"	1	B0080197
	Cleaning Tips (10/pack)	1	B0505368
	Ferrule Front 2.45	1	B3001333
	Ferrule Back 2.45	1	B3001334
	Outlet-Valve CPL	1	B3002006
	Inlet-Valve CPL	1	B3002007
	Media-Fan Filter (5/pack)	2	N2011156
	Clamp- Hose 7/32-5/8 SST (for 02507987)	2	09903004
<b>PinAAcle 900H Preventive Maintenance Kit 2 (High Sensitivity Neb)</b>			<b>N3160526</b>
	Contact Cylinders – 1 Set	1	B0128495
	AS 900 Sampling Probe	1	B0129258
	Collar - Window Holder	1	B3120294
	Tubing-Tygon SE-200 per 1 FT/0.3 M	4	02507987



Preventive  
Maintenance Kits,  
continued

Instrument Models	Description	Qty	Part No.
<b>PinAAcle 900H Preventive Maintenance Kit 2 (High Sensitivity Neb) continued</b>			<b>N3160526</b>
	Burner Head Viton O-Ring	1	09902219
	End Cap O-Ring - Large	1	09902147
	End Cap O-Ring - Small	4	09200253
	Apiezon Grease Assy	1	03030405
	High Sensitivity Neb O-Ring (0.364 ID 0.070 WD)	2	09902015
	O-Ring-Metric 2 ID 1 WD	1	09926127
	Burner Quick Connect O-Rings	6	09902047
	Nebulizer Tubing Assembly	1	B3150458
	Ceramic Ball (Neb)	1	B0505086
	PTFE Tubing (Clear) 1.75 ID X 2.45 OD	1	B0017998
	Back Ferrule 1/16"	1	B0080196
	Front Ferrule 1/16"	1	B0080197
	Cleaning Tips (10/pack)	1	B0505368
	Ferrule Front 2.45	1	B3001333
	Ferrule Back 2.45	1	B3001334
	Outlet-Valve CPL	1	B3002006
	Inlet-Valve CPL	1	B3002007
	Media-Fan Filter (5/pack)	2	N2011156
	Clamp- Hose 7/32-5/8 SST (for 02507987)	2	09903004
<b>PinAAcle 900T Preventive Maintenance Kit 1 (Stainless Steel Neb)</b>			<b>N3160523</b>
	THGA Contact Cylinders -1 Pair	1	B0504035
	AS 900 Sampling Probe	1	B0129258
	Quad-Ring 25 X 3.53	1	B0501236
	Tubing-Tygon SE-200 per 1 FT/0.3 M	4	02507987
	Burner Head Viton O-Ring	1	09902219
	End Cap O-Ring - Large	1	09902147
	End Cap O-Ring - Small	4	09200253
	Apiezon Grease Assy	1	03030405
	Neb Poly Tubing 10 FT AA	0.1	09908265
	Stainless Steel Neb O-Ring (0.364 ID 0.070 WD)	2	09902015
	Stainless Steel Neb O-Ring (0.176 ID 0.070 WD)	2	09902005
	Stainless Steel Neb O-Ring (0.208 ID 0.070 WD)	1	09902239
	Stainless Steel Neb O-Ring (0.070 ID 0.040 WD)	1	09902102
	Nebulizer PTFE Washer	1	03031802
	Burner Quick Connect O-Rings	6	09902047
	PTFE Tubing (Clear) 1.75 ID X 2.45 OD	1	B0017998
	Ferrule Front 2.45	1	B3001333
	Ferrule Back 2.45	1	B3001334
	PTFE-Hose 1.0 ID X 0.3 WD	1	B0029792
	Back Ferrule 1/16"	1	B0080196
	Front Ferrule 1/16"	1	B0080197
	Outlet-Valve CPL	1	B3002006
	Inlet-Valve CPL	1	B3002007
	Cleaning Tips (10/pack)	1	B0505368
	Media-Fan Filter (5/pack)	2	N2011156
	Clamp- Hose 7/32-5/8 SST (for 02507987)	2	09903004

**Preventive  
Maintenance Kits,  
continued**

Instrument Models	Description	Qty	Part No.
	<b>PinAAcle 900T Preventive Maintenance Kit 1 (Stainless Steel Neb)</b>		<b>N3160524</b>
	THGA Contact Cylinders -1 Pair	1	B0504035
	AS 900 Sampling Probe	1	B0129258
	Quad-Ring 25 X 3.53	1	B0501236
	Tubing-Tygon SE-200 per 1 FT/0.3 M	4	02507987
	Burner Head Viton O-Ring	1	09902219
	End Cap O-Ring - Large	1	09902147
	End Cap O-Ring - Small	4	09200253
	Apiezon Grease Assy	1	03030405
	Stainless Steel Neb O-Ring (0.364 ID 0.070 WD)	2	09902015
	Nebulizer Tubing Assembly	1	B3150458
	Ceramic Ball (Neb)	1	B0505086
	O-Ring-Metric 2 ID 1 WD	1	09926127
	Burner Quick Connect O-Rings	6	09902047
	PTFE Tubing (Clear) 1.75 ID X 2.45 OD	1	B0017998
	PTFE-Hose 1.0 ID X 0.3 WD	1	B0029792
	Back Ferrule 1/16"	1	B0080196
	Front Ferrule 1/16"	1	B0080197
	Outlet-Valve CPL	1	B3002006
	Inlet-Valve CPL	1	B3002007
	Cleaning Tips (10/pack)	1	B0505368
	Ferrule Front 2.45	1	B3001333
	Ferrule Back 2.45	1	B3001334
	Media-Fan Filter (5/pack)	2	N2011156
	Clamp- Hose 7/32-5/8 SST (for 02507987)	2	09903004



Every day you count on PerkinElmer to provide you with solutions that deliver reliable performance, control operating costs and maximize operational time. Our complete portfolio of consumables, parts, supplies, training and service helps you meet both routine and demanding measurement challenges. We invest heavily in testing and validating our products to ensure you receive guaranteed compatibility and performance – on-time, for every instrument in your laboratory.

**For a complete listing of AA consumables, please visit [www.perkinelmer.com/supplies](http://www.perkinelmer.com/supplies)**

PerkinElmer, Inc.  
940 Winter Street  
Waltham, MA 02451 USA  
P: (800) 762-4000 or  
(+1) 203-925-4602  
[www.perkinelmer.com](http://www.perkinelmer.com)



For a complete listing of our global offices, visit [www.perkinelmer.com/ContactUs](http://www.perkinelmer.com/ContactUs)

Copyright © 2011-2016, PerkinElmer, Inc. All rights reserved. PerkinElmer® is a registered trademark of PerkinElmer, Inc. All other trademarks are the property of their respective owners.



## 420 & 430 Series Single and Dual Stage SilcoNert™ 1020 Regulators



4203331-01-330 shown

All wetted components of the 420 and 430 Series single and dual stage regulators feature a non-reactive, amorphous silicon finish. This proprietary surface finish provides excellent inertness for reactive calibration standards and significantly improved corrosion resistance over bare 316L stainless steel or other more expensive alloys.

### Advanced Features

- SilcoNert™ 1020 barstock body
- SilcoNert™ 1020 diaphragm
- Front and rear panel mountable
- Metal-to-Metal diaphragm seal
- Pressure ranges 0-15 to 0-500 PSIG
- 1 x 10<sup>-9</sup> scc/sec helium leak integrity

### Typical Applications

- Continuous emission monitoring
- Environmental stack gas emission standards
- Low level sulfur analysis (ppb H<sub>2</sub>S, SO<sub>2</sub>, COS)
- Low level mercury and HCl analysis
- Reactive or corrosive gases
- Off-shore platform systems
- Corrosive and salt water exposure

## 538 Series IntelliSwitch™ II Fully Automatic Switchover System



538D006-01-000 shown

The IntelliSwitch II offers continuous pressure and flow control from liquid or high pressure cylinder sources. The end-user selects the current mode of supply on the fly by the simple push of a button. Proprietary software logic lowers yearly gas costs by eliminating liquid cylinder vent loss and excess residual return. An onboard web and e-mail server allows easy telemetry via the Internet.

### Advanced Features

- NEMA 4 enclosure
- Internal delivery pressure adjustment
- Proprietary economization algorithm
- Enhanced operating software
- Expanded system diagnostics and troubleshooting
- Remote monitoring, email capability and parameter settings via web server

### Typical Applications

- EPA Protocol standards
- Gas and liquid chromatography
- Ultra-high purity carrier gases
- Zero, span, and calibration gases
- High purity chamber pressurization

## 577 Series CryoWiz™ Liquid Cryogenic Switchover System



5771102-01-100 with real-time monitoring webserver shown

The CONCOA CryoWiz delivers a continuous supply of liquid nitrogen from a primary and secondary supply automatically with no temperature change. The CryoWiz uses a proprietary algorithm and precise pressure and temperature sensors to monitor the demand for and supply of the liquid nitrogen. With a unique insulated switching mechanism, high flow pneumatic valves, and hot gas bypass programming, the CryoWiz automatically switches sources with virtually no change in delivered cryogenic temperature.

### Advanced Features

- Insulated switching mechanism
- High flow pneumatic control valves
- Hot gas bypass
- Single compact NEMA 12 enclosure
- Onboard web and mail server
- Oxygen deficiency relay contact

### Typical Applications

- Subambient gas chromatography
- Cryopreservation
- Control rate freezers
- Environmental chambers
- Cryogenic research



## 302 Series Single Stage Brass Ultra High Purity Regulator



3022331-01-580 shown

The 302 Series regulators are intended for primary pressure control of non-corrosive, high purity or liquefied gases (up to grade 5.5) or for applications where minor fluctuations in outlet pressure due to diminishing inlet supply can be tolerated.

### Advanced Features

- Chrome-plated brass barstock body
- 316L stainless steel diaphragm
- Compact design
- Rear panel-mountable
- Pressure ranges 0-15 to 0-500 PSIG
- 1 x 10<sup>-8</sup> scc/sec helium leak integrity

### Typical Applications

- Gas and liquid chromatography
- Ultra high purity carrier
- Zero, span, and calibration gases
- High purity chamber pressurization
- Liquefied hydrocarbon gas control
- Control of cryogenic gases
- General laboratory gas control

## 312 Series Dual Stage Brass Ultra High Purity Regulator



3122331-01-580 shown

The 312 Series regulators are intended for primary pressure control of non-corrosive, high purity or liquefied gases (up to grade 5.5) for applications requiring constant pressure control and delivery regardless of supply pressure variations.

### Advanced Features

- Chrome-plated brass barstock body
- 316L stainless steel diaphragms
- Compact design
- Stable outlet pressure
- Pressure ranges 0-15 to 0-250 PSIG
- 1 x 10<sup>-8</sup> scc/sec helium leak integrity

### Typical Applications

- EPA Protocol standards
- Gas and liquid chromatography
- Ultra-high purity carrier gases
- Zero, span, and calibration gases
- High purity chamber pressurization

## 432 Series Dual Stage Stainless Steel Ultra High Purity Regulator



4323331-01-580 shown

The 432 Series regulators are intended for primary pressure control of ultra-high purity, toxic, or corrosive gases (up to grade 6.0+) for applications requiring constant pressure control and delivery regardless of supply pressure variations.

### Advanced Features

- 316L stainless steel barstock body
- 316L stainless steel diaphragms
- Pipe-away relief valve
- Metal-to-metal seals
- Stable outlet pressure
- Pressure ranges 0-15 to 0-350 PSIG
- 1 x 10<sup>-9</sup> scc/sec helium leak integrity

### Typical Applications

- Toxic and corrosive gases
- Research grade gases
- EPA Protocol standards
- Gas and liquid chromatography
- Ultra-high purity carrier gases
- Zero, span, and calibration gases
- Ultra-high purity chamber pressurization

## 212 Series Dual Stage High Purity General Purpose Regulator



2121351-01-580 shown

The 212 Series regulators are intended for primary pressure control of non-corrosive, high purity or liquefied gases (up to grade 4.5) for applications requiring constant pressure control and delivery regardless of supply pressure variations.

### Advanced Features

- Chrome-plated forged brass body
- High flow capacity
- Pressure ranges 0-15 to 0-200 PSIG
- Extremely stable outlet pressure

### Typical Applications

- Gas supply purging
- Gas system charging
- AA fuel gas supply control
- Calibration gas control

## 492/493 Series High Pressure Regulator



4924851-01-680 shown

The 492 Series chrome-plated brass and 493 Series stainless steel regulators are intended for primary pressure control of non-corrosive gases at a maximum inlet pressure of 6000 PSIG.

### Advanced Features

- Chrome-plated brass or stainless steel barstock body
- Front and rear panel-mountable
- Pressure ranges 0-750 to 0-6000 PSIG
- Six-port configuration design
- Metering valve outlet option

### Typical Applications

- R&D laboratories
- Chemical manufacturing
- Pharmaceutical manufacturing
- Gauge calibration

## 325 Series Chrome-Plated Brass Lecture Bottle Regulator



3253351-01-180 shown

The 325 Series chrome-plated brass regulators are specifically designed for use with non-corrosive gases in lecture bottles. (The 322 Series stainless steel regulators may be used with mildly corrosive gases in lecture bottle applications.)

## 206 Series Single Stage Liquid Cylinder Regulator



2063001-01-580 shown

The 206 Series chrome-plated forged brass body regulators are intended for primary pressure control of gases supplied from cryogenic liquid cylinders. Though optimized for flow with liquid cylinders, the regulators are rated to 3000 PSIG for safe use in high pressure applications.

### Advanced Features

- Chrome-plated forged brass body
- 316L stainless steel diaphragm
- 1x10<sup>-8</sup> scc/sec helium leak integrity

### Typical Applications

- Laboratory liquid cylinders
- ICP, ICP-MS, and mass spectrometers
- Liquid reserve systems

### Advanced Features

- Chrome-plated brass barstock
- Low droop
- 1½ pressure gauges

### Typical Applications

- University classrooms
- University laboratories
- Chemical research

## Oxygen Deficiency Alarm



The 3004 Series Oxygen Deficiency Alarm monitors oxygen levels in any area where inert gases or confined space may produce hazardous reduction in the oxygen content of the air.

### Advanced Features

- NEMA 4x enclosure
- Operating temperatures -40 to 55°C
- Long-lasting zirconium sensor

### Typical Applications

- Cryopreservation facilities
- Laboratories
- Liquefied or compressed gas storage areas

## 526/527 Series Automatic Switchover



The 526 Series brass and 527 Series stainless steel switchovers are designed to supply a continuous supply of high purity gas (up to grade 6.0+). The system comes with either flexible hoses for use with two cylinders or manifold connectors for use with the Maniflex Modular Manifold System. Due to pressure differential considerations, an integral line regulator is available to maintain constant downstream pressure.



5267021-01-001 switchover with optional Advantium 2 Plus alarm shown

## 315 Series Dual Stage Medical Laboratory Regulator



3158381-01-M1D shown

The 315 Series regulators are specifically designed for use on cylinders with medical "E" or "D" post valve connections in clinical gas applications requiring constant pressure control and delivery regardless of supply pressure variations. These regulators, as well as the 305 Series single stage version, can also be ordered with standard CGA connections for larger cylinders.

### Custom Calibration

In addition to a standard 2-15 lpm flow gauge for CO<sub>2</sub>, CONCOA also offers a custom 2-15 lpm calibration for any non-corrosive gas or mixture. The outlet orifice is sized to the flow requirement for a specific gas using a thermal mass flowmeter.

## Cabinets



C1-2023331-580M

The CONCOA C Series Gas Cabinet Systems safely deliver high purity gases that pose a hazard due to their properties or location. Available in a variety of configurations to contain up to four cylinders along with pressure, flow, and safety equipment, CONCOA C Series Gas Cabinet Systems enable safe, reliable, and compliant use of flammable, pyrophoric, toxic, corrosive or oxidizing gases. For example, these systems can ease the transition to hydrogen use for analysis by providing a safe source within the laboratory. C Series Gas Cabinet Systems can also be configured with automated safety control systems for toxic or corrosive gases like hydrogen sulfide or carbon monoxide that include gas detection, excess flow shutdown, and emergency shutdown controllers to meet specific regulatory or facility safety requirements.

## 565 Series 65mm Flowmeter



5655111-01-HB4 shown

The 565 Series 65mm variable area flowmeters offer inherent simplicity, versatility, and economy in a precision flow instrument. The compact size of the 65mm scale is preferred in industrial panel-mounting applications and for direct mounting to a pressure regulator. Flow readings from the millimeter scale are converted to actual flow. CONCOA offers a wide variety of flowtube and float combinations to provide the optimum flow range for any application.