



Ventura County Community College District

PURCHASING DEPARTMENT

DATE: February 1, 2021
TO: All Bidders
FROM: Jo Nell Miller, Purchasing Specialist
SUBJECT: Addendum 2 – Bid 618 Fire Technology Apparatus Building
Phase III Fabrication, Installation and Final Utilities Connections

*This addendum is hereby made part of the Contract Documents to the same extent as though it was originally included therein and takes precedence over the original documents. The outdated pages must be replaced with any updated and/or changed pages when submitting your bid. Acknowledge receipt of all addenda on the **Bid Form – Addendum 2 Revision** (attached).*

The bid opening remains on **Monday, February 8, 2021**. Bids must be received no later than **3:00 p.m.** at 761 E Daily Drive, Suite 200, Camarillo, CA 93010. Properly mark the outside of the exterior envelope on your submitted bid with the **Bid Number and Name** according to the requirements stated in the bid packet directions.

If you choose not to participate in this particular bid, please sign the Bid Proposal stating “no bid” and email it back to me.

It is the responsibility of the Bidder to verify that their proposal has been received by the VCCCD Purchasing Department prior to the opening date. Verification of receipt can be made through the listed Purchasing Specialist.

The following information is in answer to questions that were submitted by email before the deadline. The deadline for questions was Thursday, January 28, 2021. No further questions will be accepted.

1. Existing conditions at building pad excavation:

Contractor shall remove all existing debris in the building excavation and dispose of in a legal manner. The resulting bottom will be surveyed and verified rough grade complies with contract documents. Excess material shall be removed off and disposed of, unless acceptable to be used as fill material for building pad. Should the resulting bottom require additional fill to bring to rough grades shown on grading plan, contractor shall import and place said material to satisfaction of the geotechnical consultant. **Bidders to provide the following unit costs as found on the Bid Proposal – Addendum 2 Revision:**

Example:

Bid price for excavation preparation _____ lump sum.

Bid price for removal and disposal of excess material _____ cubic yard of export/dispose.

Bid price for importation and placement of soil to rough grade elevation, prior to building matt placement _____ cubic yard of import and placement.



Ventura County Community College District

PURCHASING DEPARTMENT

2. No substitutions for Varco Pruden wall panels and roof panels were submitted for review, therefore the Contractor shall provide the product by this manufacturer. Information about purchase/installation should be obtained directly from the manufacturer. There are no other bidding restrictions for the steel building construction/acquisition. General Contractors shall bid the entire construction project as documented on the DSA approved drawings, with the exception of Sheets GI-1 through GI-4, as the soil improvement scope has already been completed under separate contract.
3. For constructing the Geogrid reinforced raft, material used can be CMB or CAB, provided that the material size is 1" minus as specified.
4. The soil improvement sheets, G1-3, of the construction drawings, represent work that has Contractor to install sampling well per attached City of Camarillo Std Plate 7. Location is shown schematically on the attached Sewer plan, Sheet C4. Contractor shall coordinate location with Plumbing plans so that only waste from laundry is accepted in the well. Sanitary waste lines will connect to the sewer lateral downstream of the sampling well. .
5. Attached are the following drawings:
 - a. Sampling/Monitoring Manhole Std. Plate 7
 - b. C-4 Sewer Plan

End of Section

BID PROPOSAL
Section 00210
Addendum 2 Revision

TO: **VENTURA COUNTY COMMUNITY COLLEGE DISTRICT**, a California Community College District, acting by and through its Board of Trustees ("District"), at 761 E. Daily Drive, Suite 200, Camarillo, CA 93010.

FROM: _____
(Name of Bidder - as listed on license)

(Address)

(City, State, Zip Code)

(Telephone) _____ *(Fax)* _____

(E-Mail Address)

(Name(s) of Bidder's Authorized Representative(s) and Title)

1.01 Bid Proposal

A. Bid Proposal Amount

Pursuant to and in compliance with the Notice to Contractors Calling for Bids, the Instructions for Bidders and the other documents relating thereto, the undersigned Bidder, having reviewed the Instructions for Bidders and all other Contract Documents and upon compliance with all requirements therein with reference to the submittal of this Bid Proposal, hereby proposes and agrees to perform the Contract including, without limitation, all of its component parts; to perform everything required to be performed; to provide and furnish any and all of the labor, materials, tools, equipment, applicable taxes, and services necessary to perform the work of the Contract in strict compliance with the Contract Documents and complete in a workmanlike manner all of the Work required for the Project described as:

Bid 618, Fire Technology Apparatus Building Phase III Fabrication, Installation and Final Utilities Connections.

Base Bid Amount: \$ _____
(Total bid amount in figures)

_____ Dollars
(Total bid amount in words)

Price breakdown as described in Addendum 2, Item 1.

Bid price for excavation preparation _____ / lump sum.

Bid price for removal and disposal of excess material _____ / cubic yard of export/dispose.

Bid price for importation and placement of soil to rough grade elevation, prior to building matt placement _____ / cubic yard of import and placement.

B. Acknowledgment of Bid Addenda

In submitting this Bid Proposal, the undersigned Bidder acknowledges receipt of all Bid Addenda issued by or on behalf of the District, as set forth below. The Bidder confirms that this Bid Proposal incorporates and is inclusive of, all items or other matters contained in Bid Addenda.

_____ **No Addenda Issued**
(initial)

_____ **Addenda Nos. _____ received, acknowledged and**
(initial) **incorporated into this Bid Proposal.**

1.02 Rejection of Bid; Holding Open of Bid

It is understood that the District reserves the right to reject this Bid Proposal and that this Bid Proposal shall remain open and not be withdrawn for the period of time specified in the Call for Bids, except as provided by law.

1.03 Documents Comprising Bid Proposal

The undersigned Bidder has submitted as its Bid Proposal the following: Bid Proposal (00210), List of Subcontractors (00215), Non-Collusion Affidavit (00220), Statement of Bidder’s Qualifications (00240), Bid Security (Cash, Cashier’s Check, Certified Check or Bid Bond (00260) and Verification of DIR Registration.

The Bidder acknowledges that if this Bid Proposal and the foregoing documents are not fully in compliance with applicable requirements set forth in the Call for Bids, the Instructions for Bidders and in each of the foregoing documents, the Bid Proposal may be rejected as non-responsive.

1.04 Award of Contract

It is understood and agreed that if written notice of the acceptance of this Bid Proposal and award of the Contract thereon is mailed or delivered by the District to the undersigned after the opening of Bid Proposals and within the time this Bid Proposal is required to remain open or at any time thereafter before this Bid Proposal is withdrawn, the undersigned will execute and deliver to the District the Agreement in the form attached hereto in accordance with the Bid Proposal as accepted within seven (7) calendar days after notification of acceptance and award. Concurrently with delivery of the executed Agreement to the District, the Bidder awarded the Contract shall deliver to the District: (1) the Labor and Material Payment Bond; (2) the Performance Bond; (3) the Drug-Free Workplace Certificate; (4) Certificates of Insurance evidencing all insurance coverages required to be provided under the Contract Documents; and (5) the Certificate of Workers’ Compensation Insurance. The Work under the Contract Documents shall be commenced by the undersigned Bidder, if awarded the Contract, on the date stated in the District's Notice to Proceed issued pursuant to the Contract Documents.

Completion of the Work and all Interim Milestones shall be achieved within the Contract Time and Interim Milestones specified in the Contract Documents.

1.05 Notices

All notices or other correspondence shall be addressed to the District and the Bidder at their respective addresses set forth herein. Notices shall be effective only if in writing and in conformity with the requirements for service of notices set forth in the Contract Documents.

1.06 Contractor's License

The undersigned Bidder is currently and duly licensed in accordance with the California Contractors License Law, California Business & Professions Code §§7000 et seq., under the following:

License Number: _____
Class _____ Expiration Date _____ Class _____ Expiration Date _____
Class _____ Expiration Date _____ Class _____ Expiration Date _____

DIR Registration Number: _____ Expiration Date: _____

By executing this Bid Proposal, the Bidder hereby certifies that: (a) it is duly licensed, in the necessary class(es), for performing the Work of the Contract Documents; (b) that such license shall be in full force and effect throughout the duration of the performance of the Work under the Contract Documents; and (c) that all Subcontractors providing or performing any portion of the Work of the Contract Documents shall be so similarly and appropriately licensed to perform or provide such portion of the Work.

1.07 Designation of Subcontractors

In compliance with the Subletting and Subcontracting Fair Practices Act (California Public Contract Code §§4100, et seq.) and amendments thereof, each Bidder shall set forth in the Subcontractors List: (a) the name and location of the place of business of each Subcontractor who will perform work or labor or render services to the Bidder in or about the construction of the Work to be performed under the Contract Documents in an amount in excess of one-half of one percent (0.5%) of the Bidder's Bid Proposal; and (b) the trade and/or portion of the Work which will be performed by each listed Subcontractor. The Bidder shall list only one Subcontractor for each trade and/or portion of the Work as is defined by the Bidder in its Bid Proposal. If a Bidder fails to list a Subcontractor for a portion of the work in excess of one-half of one percent (0.5%) of the Bidder's Bid Proposal or if the Bidder specifies more than one Subcontractor for the same portion of Work to be performed under the Contract Documents valued in excess of one-half of one percent (0.5%) of the Bidder's Bid Proposal amount, the Bidder shall be deemed to have agreed that it is fully qualified to perform that portion of the Work itself and that it shall perform that portion of the Work.

1.08 Confirmation of Figures

By submitting this Bid Proposal, the Bidder confirms that it has checked all of the above figures and understands that neither the District nor any of its agents, employees or representatives shall be responsible for any errors or omissions on the part of the undersigned Bidder in preparing and submitting this Bid Proposal. All amounts will be entered on the proposal in the written amount and listed in figures. In the event there is a discrepancy between the bidder's written amounts and figures, the written amount will prevail.

1.09 Acknowledgment and Confirmation

The undersigned Bidder acknowledges its receipt, review and understanding of the Drawings, the Specifications and other Contract Documents pertaining to the proposed Work. The undersigned Bidder certifies that the Contract Documents are, in its opinion, adequate, feasible and complete for providing, performing and constructing the Work in a sound and suitable manner for the use specified and intended by the Contract Documents. The undersigned Bidder certifies that it has, or has available, all necessary equipment, personnel, materials, facilities and technical and financial ability to complete the Work for the amount bid herein within the Contract Time and in accordance with the Contract Documents. The undersigned Bidder certifies that its bid amount includes funds sufficient to allow the Bidder to comply with all applicable local, state and federal laws and regulations governing the labor and services to be provided for the performance of the Work of the Contract and shall indemnify, defend and hold District harmless from and against any and all claims, demands, losses, liabilities and damages arising out of or relating to Bidder's failure to comply with applicable law in this regard.

By: _____
(Signature & Date)

(Corporate Seal)

(Typed or Printed Name of Bidder's Authorized Representative)

Title: _____

Date: _____

[End Of Section]

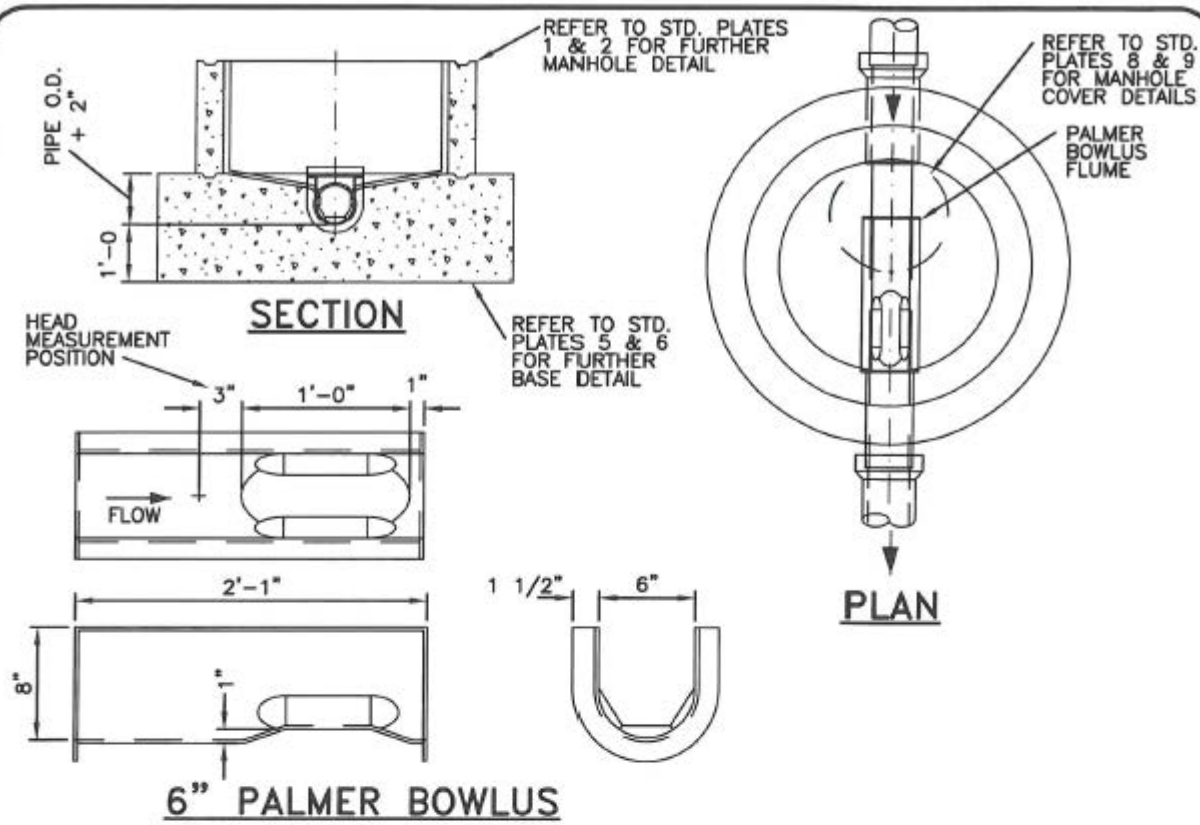

6" PALMER BOWLUS

NOTES:

1. SAMPLING MANHOLE SHALL BE LOCATED ON PRIVATE PROPERTY OUTSIDE THE CITY PUBLIC RIGHT OF WAY. CAMARILLO SANITARY DISTRICT SHALL HAVE ACCESS TO THE SAMPLING MANHOLE AT ALL TIMES.
2. FINAL APPROVAL RELATIVE TO THE REQUIREMENTS FOR THE SAMPLING MANHOLE EQUIPMENT INCLUDING BUT NOT LIMITED TO THE SPECIFIC TYPE, SIZE AND SLOPE SHALL BE MADE BY THE CITY ENGINEER.
3. MANHOLE BASE RISER SECTIONS AND TOP SHALL CONFORM TO APPLICABLE STD. PLATES 1, 2, 3, 4, 5, 6, 8 & 9.
4. THE PREFABRICATED FIBERGLASS REINFORCED PLASTIC (FRP) PALMER BOWLUS FLUME AS MANUFACTURED BY PLASTI-FAB (OR APPROVED EQUAL) SHALL BE INSTALLED ACCORDING TO THE MANUFACTURER'S RECOMMENDATIONS.
5. NO BUILDING LATERAL CONNECTION SHALL BE MADE DOWNSTREAM OF ITS SAMPLING MANHOLE.
6. IN ORDER TO CONTROL VELOCITIES, NO SLOPE CHANGES, DEFLECTION AND/OR CONNECTIONS SHALL BE ALLOWED WITHIN A DISTANCE 15 TIMES THE SEWER PIPE I.D. UPSTREAM AND/OR DOWNSTREAM OF THE SAMPLING MANHOLE.
7. THE SLOPE OF THE PIPE SHALL NOT EXCEED 1 PERCENT THROUGH THE SAMPLING MANHOLE FOR A DISTANCE OF 15 TIMES THE PIPE I.D. BOTH UPSTREAM AND DOWNSTREAM OF THE SAMPLING MANHOLE.
8. DOWNSTREAM SEWER SHALL BE DESIGNED TO CONVEY THE MAXIMUM DESIGN FLOWS WITHOUT CREATING A SURCHARGED CONDITION IN THE SAMPLING MANHOLE.

	<p>Camarillo Sanitary District 601 Carmen Drive Camarillo, CA 93010 (805) 388-5340</p>	<p>SAMPLING/MONITORING MANHOLE (PALMER BOWLUS FLUME)</p>								
Reviewed: <i>WMM TL</i>	3/26/2015	<table border="1" style="width: 100%; border-collapse: collapse;"> <thead> <tr> <th style="width: 50%;">REVISIONS</th> <th style="width: 10%;">BY</th> <th style="width: 10%;">DATE</th> <th style="width: 20%;">STD. PLATE</th> </tr> </thead> <tbody> <tr> <td> </td> <td> </td> <td> </td> <td style="text-align: center; vertical-align: middle;">7</td> </tr> </tbody> </table>	REVISIONS	BY	DATE	STD. PLATE				7
REVISIONS	BY	DATE	STD. PLATE							
			7							
Approved: <i>Moffatt Tucker</i>	3/31/15									
Sanitary Superintendent	Date									
City Engineer	Date									